



INSTALLATION INSTRUCTIONS

Accessory
ENGINE BLOCK HEATER
P/N 08T44-SNA-102

Application
2018 TLX V6

Publications No.
VERSION 1
Issue Date
MAY 2017

PARTS LIST

Engine block heater



Aluminum washer



Heater harness

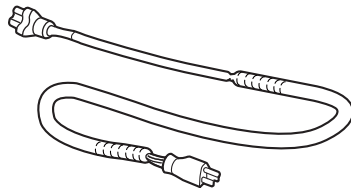

Protective cap



12 Black wire ties
(Some may not be used)



7 Wire ties with clip
(6 Not used)



5 Brown wire ties



TOOLS AND SUPPLIES REQUIRED

Phillips screwdriver

Ratchet

10 mm, 19 mm, and 24 mm Sockets

10 mm Open end wrench

Torque wrench

Diagonal cutters

Heavy gloves

Drain pan

Tape measure

Ruler

White marker

Coolant (Acura Long Life Antifreeze/Coolant Type 2)

Blanket

Fender cover

Masking tape

Pushpin

Drill

3 mm and 5 mm Drill bits

15 mm and 28 mm Hole saws

Eye protection (face shield, safety goggles, etc.)

Hacksaw

File

The following tools are available through the Acura Tool and Equipment Program. On the iN, click on: Service > Service Bay > Tool and Equipment Program, then enter the number under "Search." Or, call 888-424-6857.

- Trim Tool Set (T/N SOJATP2014)
- Plastic Trim Tool (T/N SILTRIMTL10)

Illustration of the Engine Block Heater Installed on the Vehicle

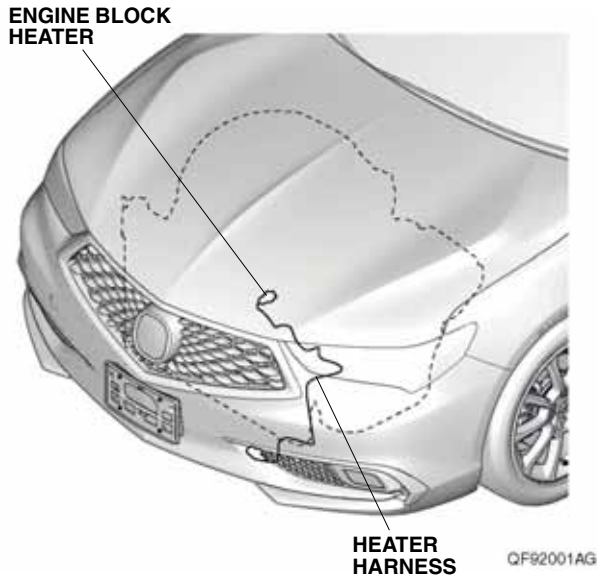

INSTALLATION

Client Information: The information in this installation instruction is intended for use only by skilled technicians who have the proper tools, equipment, and training to correctly and safely add equipment to your vehicle. These procedures should not be attempted by “do-it-yourselfers.”

NOTE:

- Always use Acura Long Life Antifreeze/Coolant Type 2. Using a non-Acura coolant can result in corrosion, causing the cooling system to malfunction or fail.
 - To avoid burning out the element, do not operate the engine block heater until it is installed in the vehicle and you have added coolant.
 - Follow the same procedures to remove the vehicle parts for A-spec models.
1. Disconnect the negative cable from the battery.
 2. Allow the engine and all cooling system components to cool down.

3. Remove the cover. Place a clean drain pan under the radiator drain plug, then remove the drain plug from the bottom of the radiator to drain the coolant. Remove the radiator cap to increase the flow.

NOTICE: Radiator coolant will damage the paint. Quickly rinse any spilled coolant from the paint.

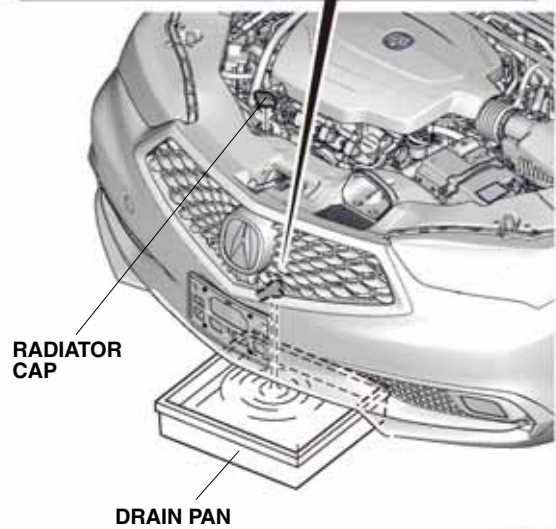
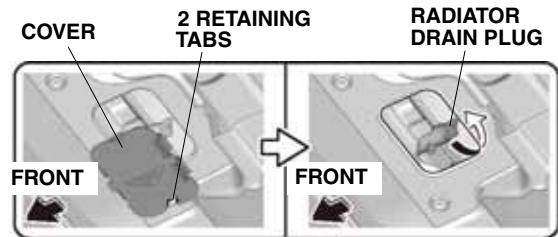

4. Drain the coolant completely, then reinstall the radiator cap.

5. Apply masking tape to the front bumper, headlights and front fenders as shown.

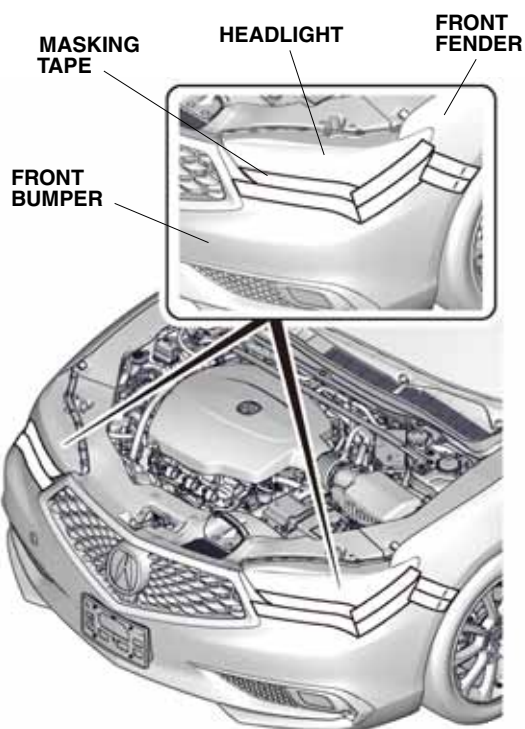

QF90902AC

6. Remove the air intake tube.

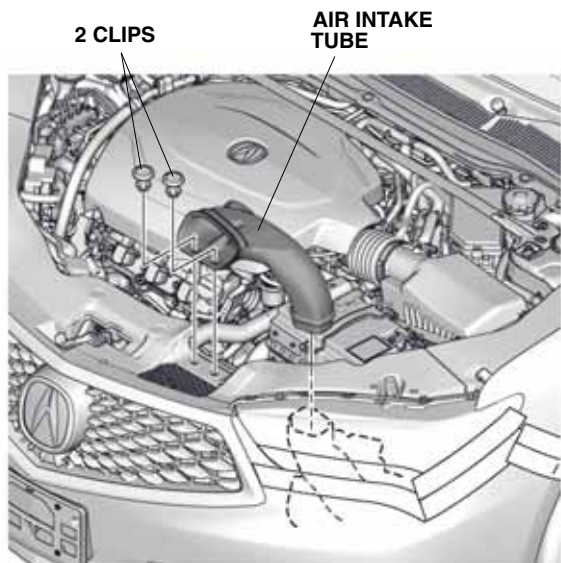

QF90903AC

7. Remove the front grille cover.

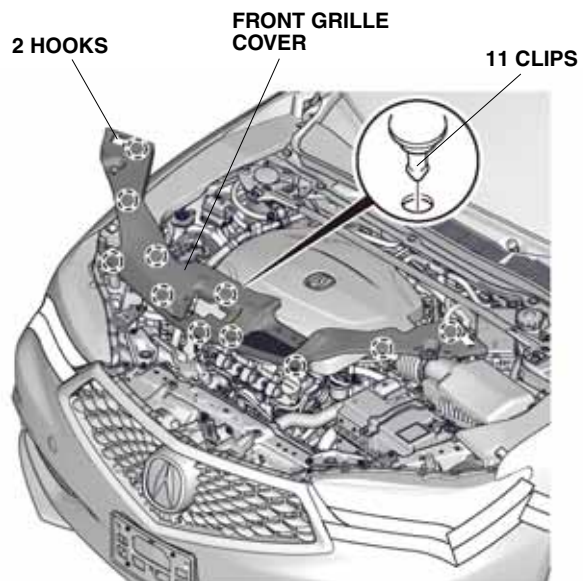

QF90904AC

8. Remove the two bolts and three clips from the front grille.

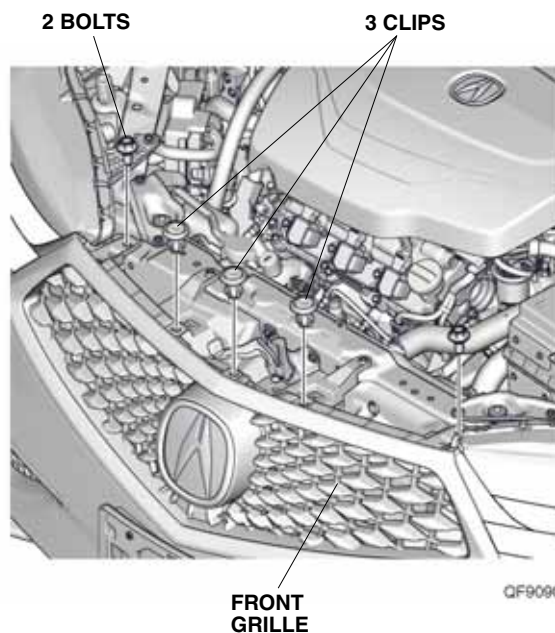

QF90905AC

9. Remove the left strake from the front bumper and air dam.

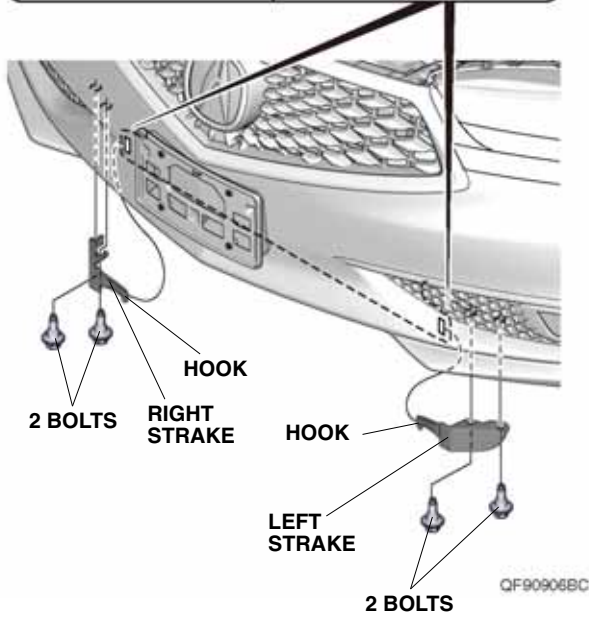
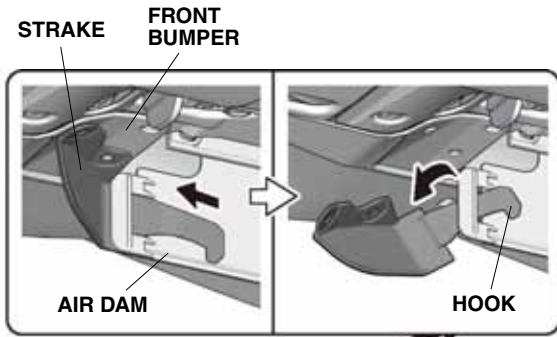

10. Repeat the procedure to remove the right strake.

11. Remove the front bumper:

- Remove the two long self-tapping screws, four short self-tapping screws, four clips, and six bolts.

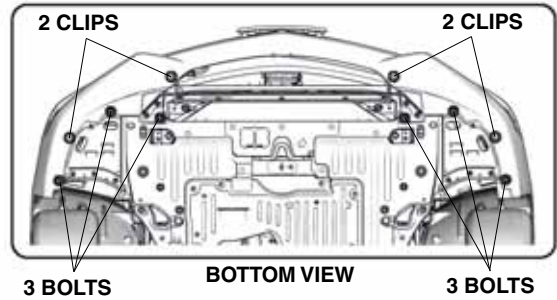
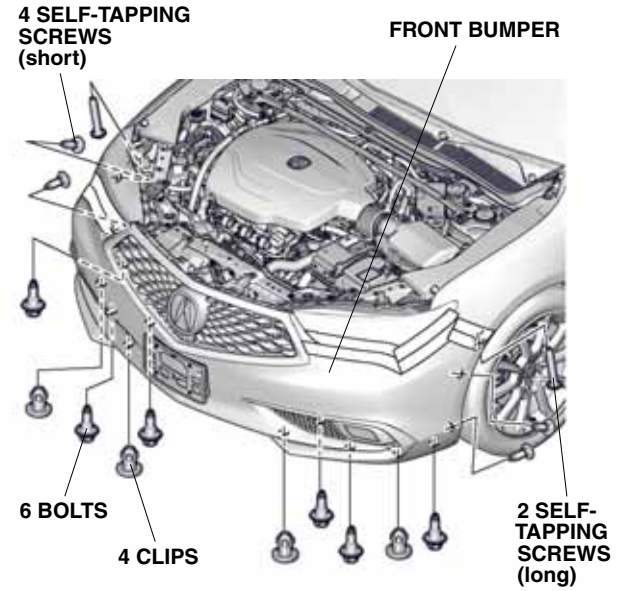

- Release the five retaining tabs on each side.

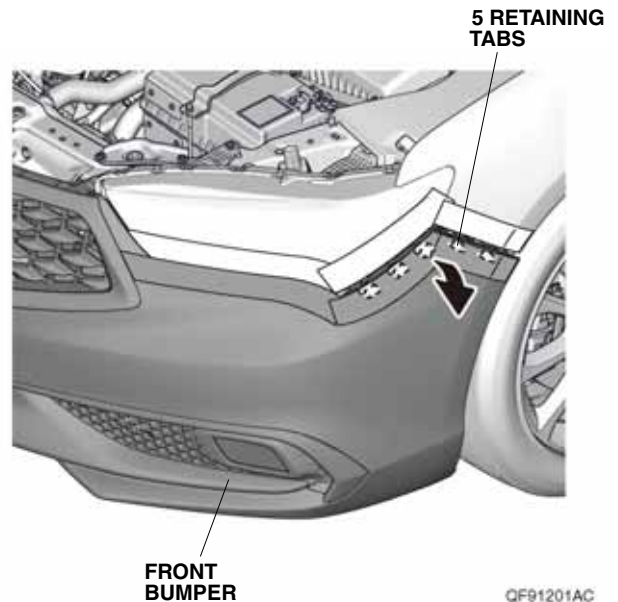

- Release the two retaining tabs on each side.

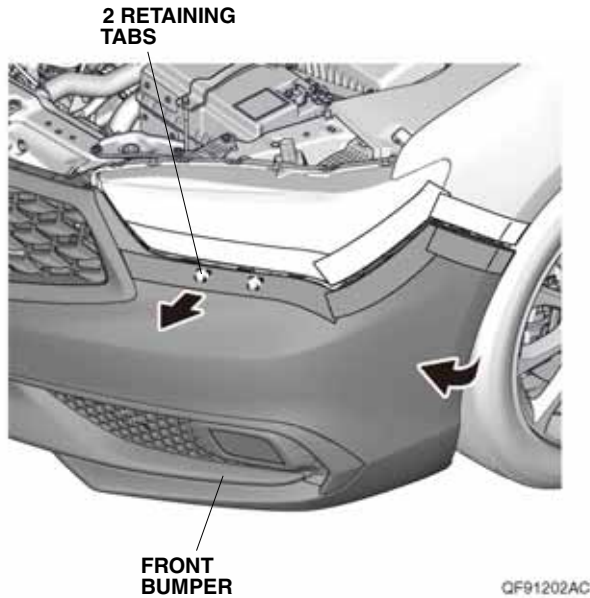

- With the help of an assistant, remove the front bumper.
- Unplug the vehicle connectors and remove the clip if equipped.
- Place the front bumper on a blanket.

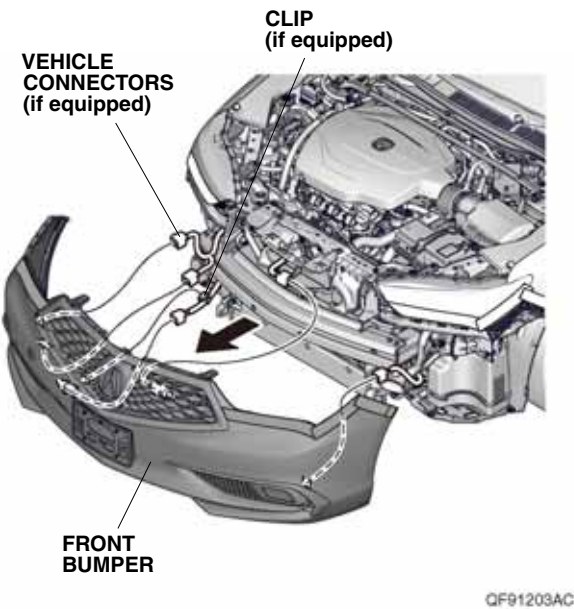

- Using a tape measure and a white marker, mark the heater harness at the measurements **A**, **B**, **C**, **D**, **E**, and **F**.

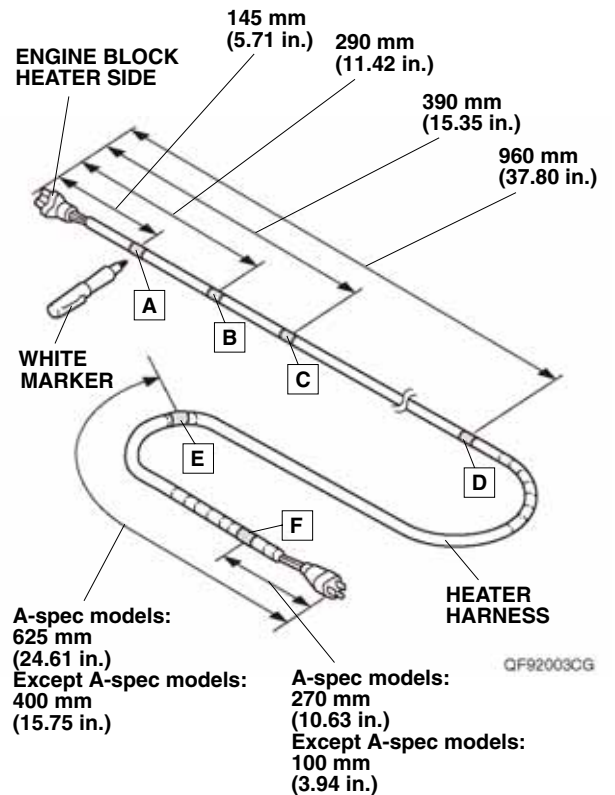

- Install one wire tie with clip to the heater harness at point **B**.

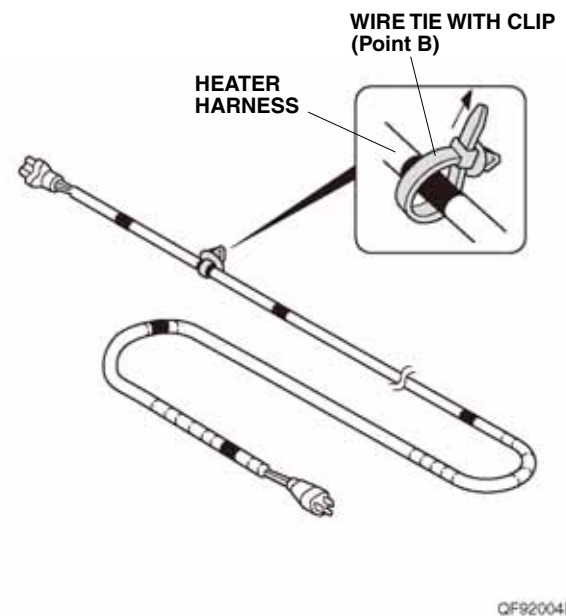

14. Locate and remove the drain bolt and washer. Coolant remaining in the engine jackets flows out of the hole when the drain bolt is removed. Retain the drain bolt; it will be used if the engine block heater is removed.
NOTE: Use a new washer if the drain bolt is reinstalled.

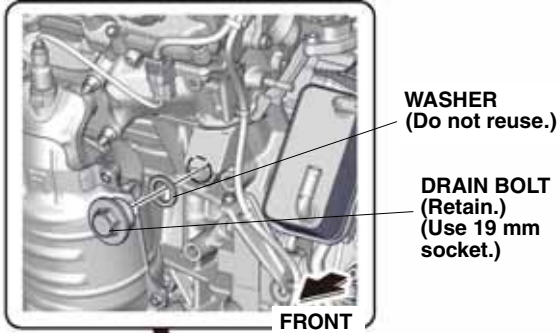

QF92005AG

15. Install the engine block heater with the aluminum washer to the bolt hole using a 24 mm socket. Torque the engine block heater to 80 N·m (59 lb·ft).

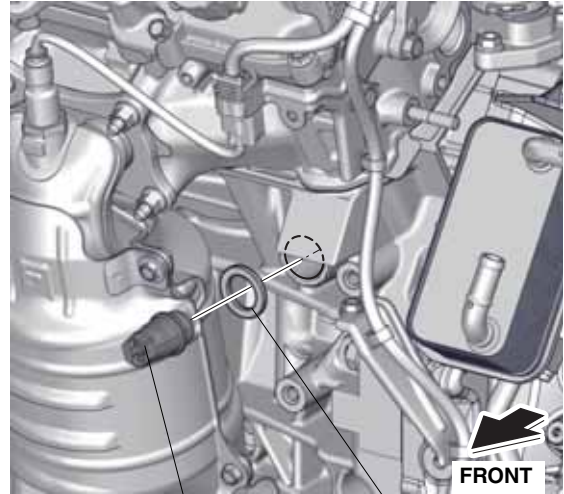

QCN1106AB

16. Plug the heater harness connector into the engine block heater. Make sure the heater harness connector is fully seated in the engine block heater.

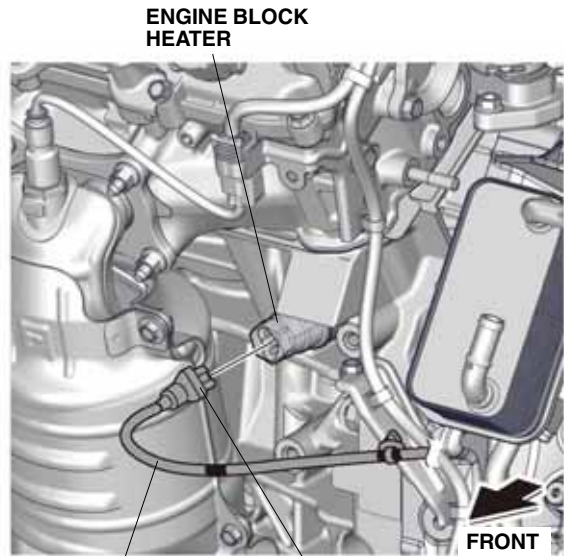

QF92006AG

- Route the heater harness in the direction shown, and secure it to the vehicle bracket with one wire tie with clip installed in step 13.

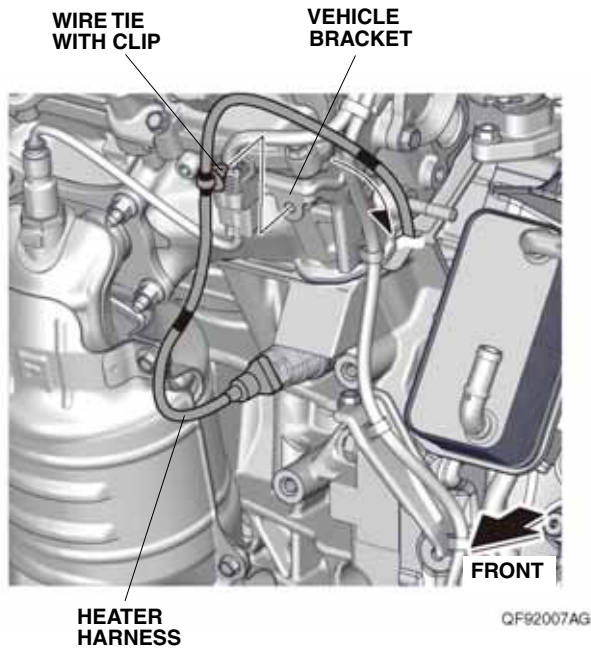

- Secure the heater harness to the vehicle harness with one brown wire tie at point **A**. Secure the heater harness to the vehicle harness with one brown wire tie.

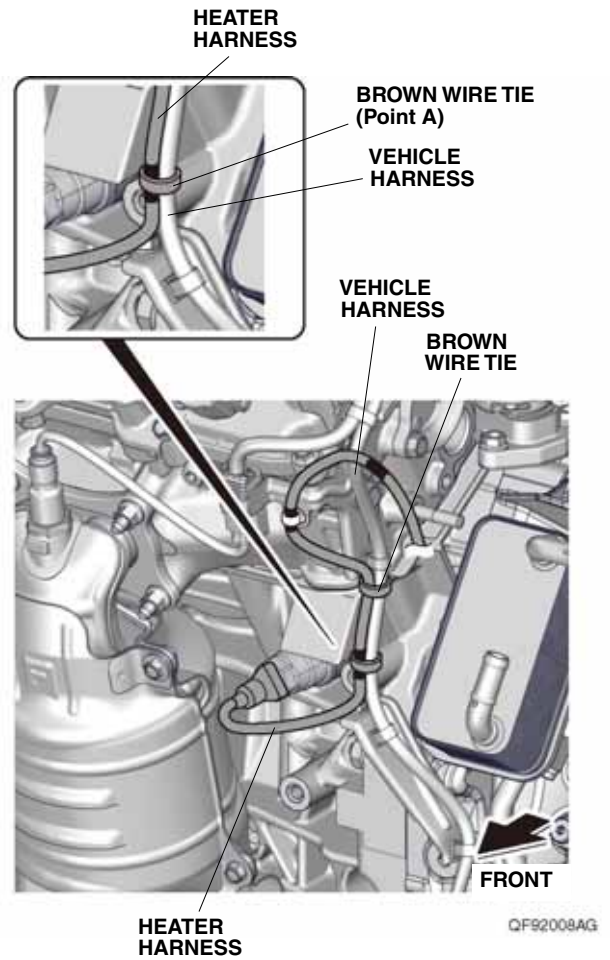

19. Route the heater harness toward the fan shroud, and secure it to the fan shroud rib with one brown wire tie at point **C**.

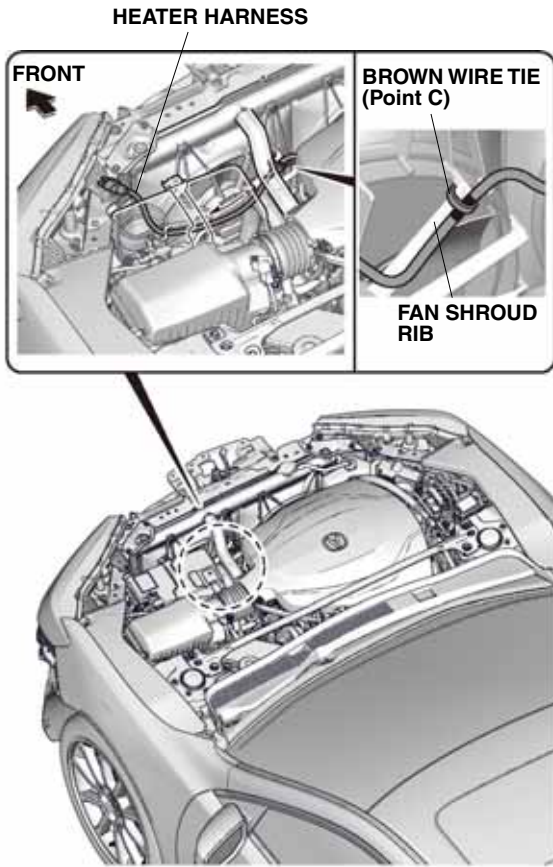

QF92009AG

20. Route the heater harness down behind the front bumper beam, and secure it to the vehicle harness with one black wire tie at point **D**. Secure the heater harness to the vehicle harness with one black wire tie.

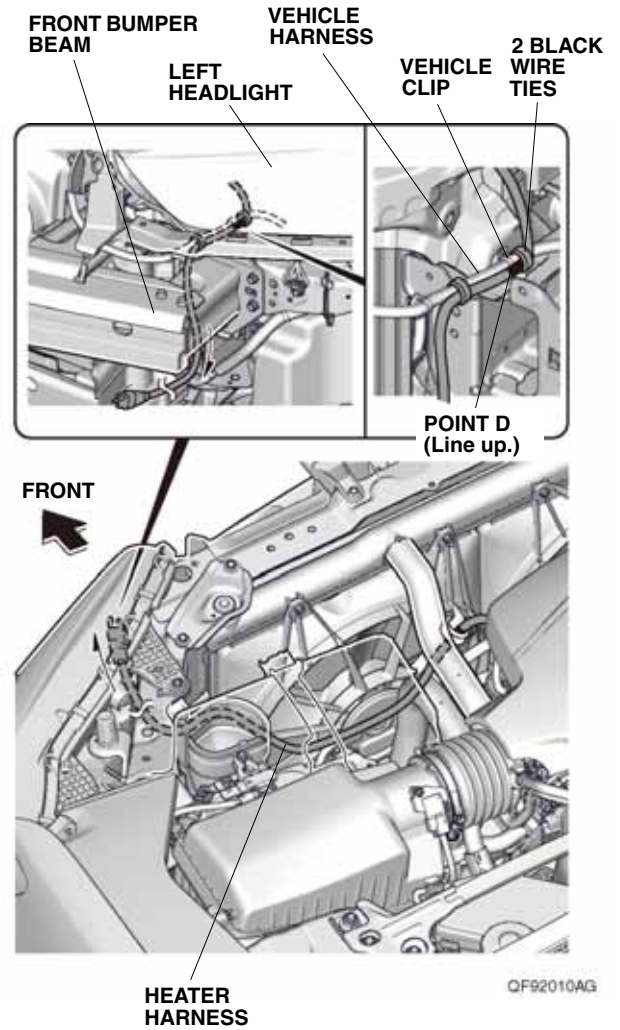

QF92010AG

21. Secure the heater harness to the fan shroud ribs with two brown wire ties and two black wire ties.

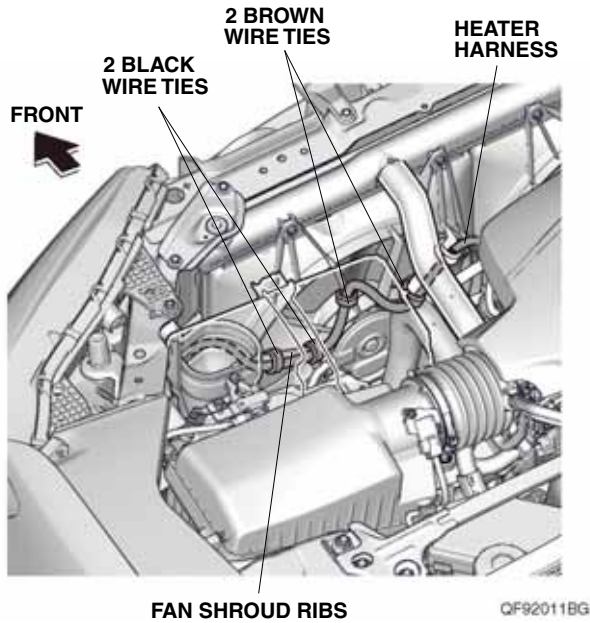

22. Bundle up the excess heater harness, and secure it to the vehicle harness with one black wire tie at point E.

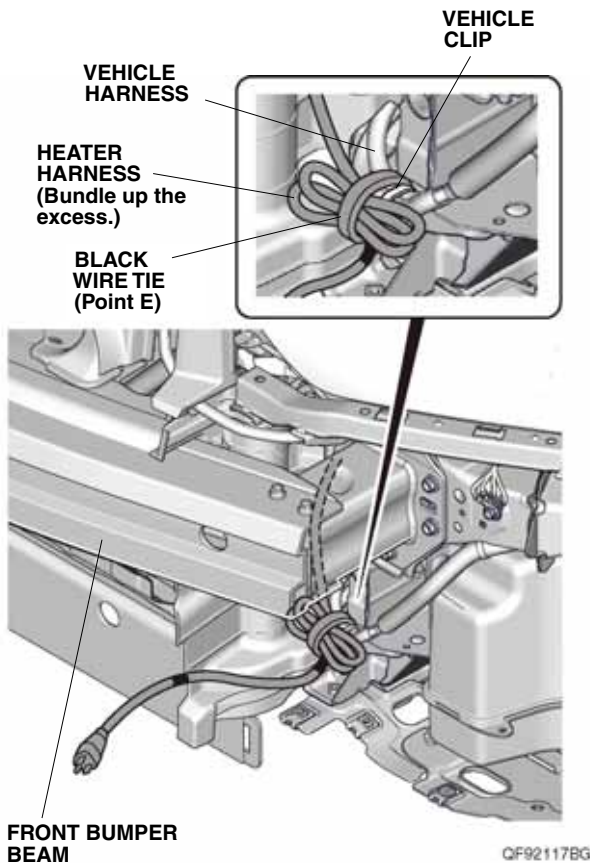

If the vehicle is A-spec models, continue with step 23; otherwise, go to step 27.

A-spec models

23. Using a hacksaw, cut out the front lower grille as shown. Remove any burrs.

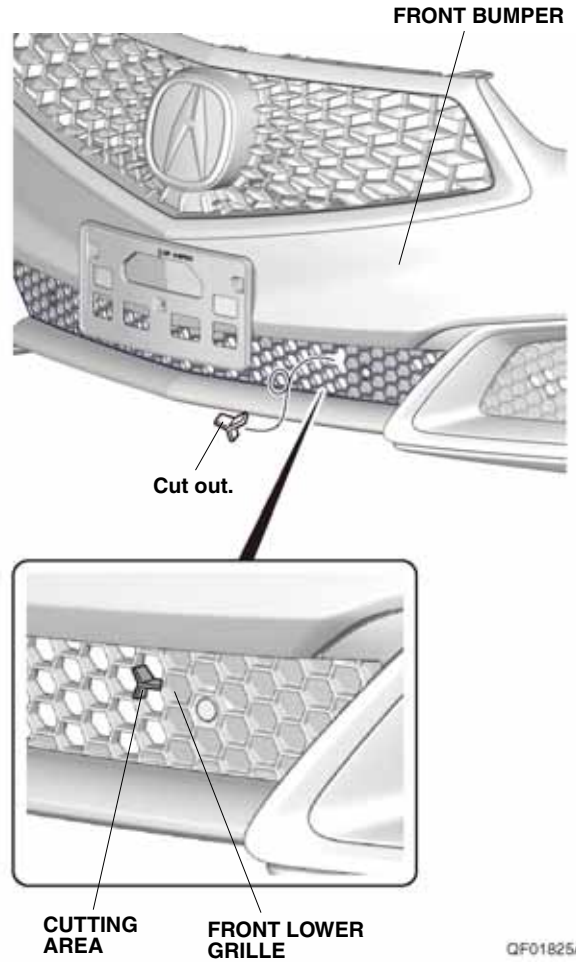

24. Attach the protective cap to the front lower grille.

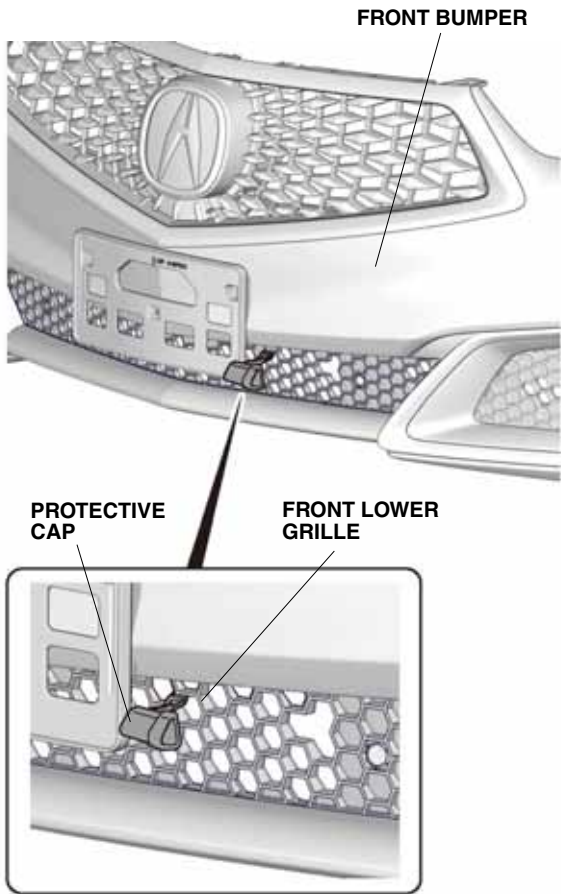

QF01826AB

25. With the help of an assistant, bring the front bumper close to the vehicle. Route the heater harness through the cutout in the front lower grille as shown, then secure it to the vehicle harness or front lower grille with one black wire tie at point **F**. Install the front bumper.

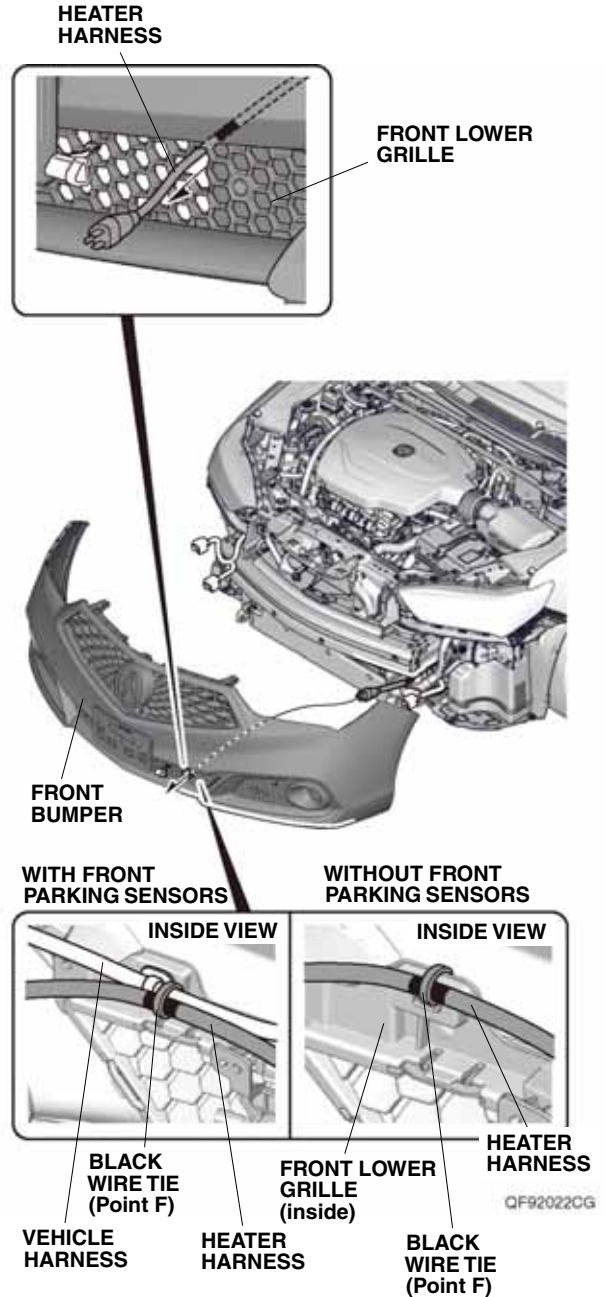

26. Plug the heater harness connector into the protective cap, then secure the heater harness to the front lower grille with one black wire tie. Go to step 36.

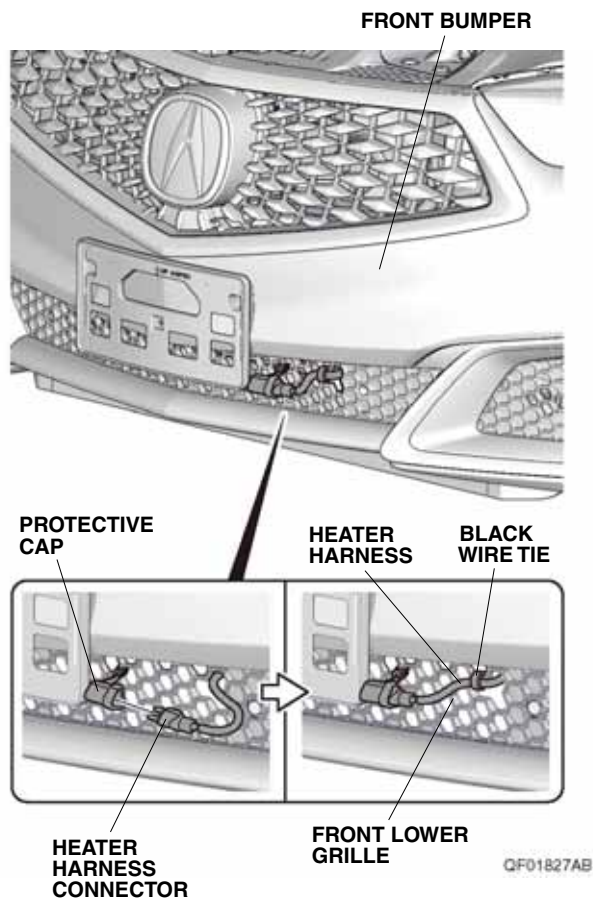

Except A-spec models

27. Using a pushpin, pierce the inside of the left cover through the center of three scribe marks.
NOTE: Make sure to pierce perpendicular to the left cover.

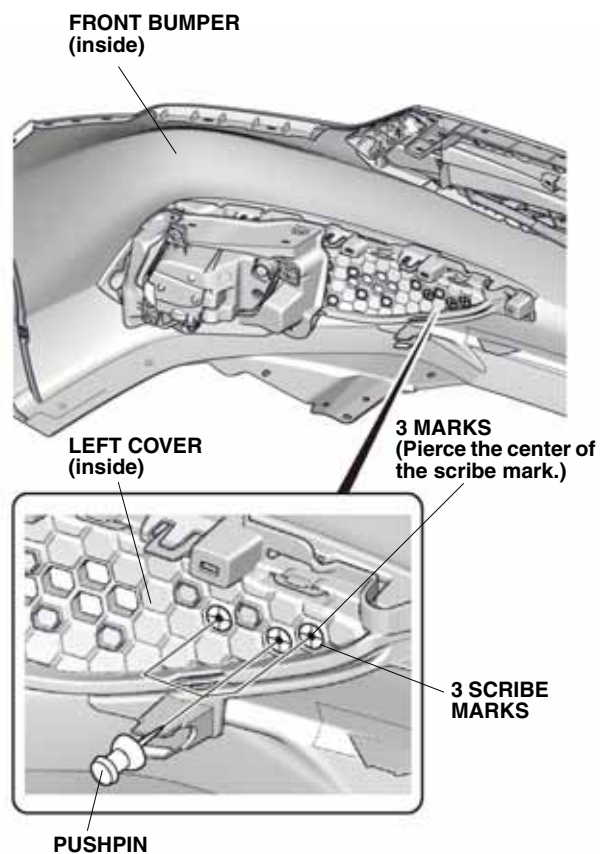

28. Using a pushpin, pierce the inside of the left cover as shown.
 NOTE: Make sure to pierce perpendicular to the left cover.

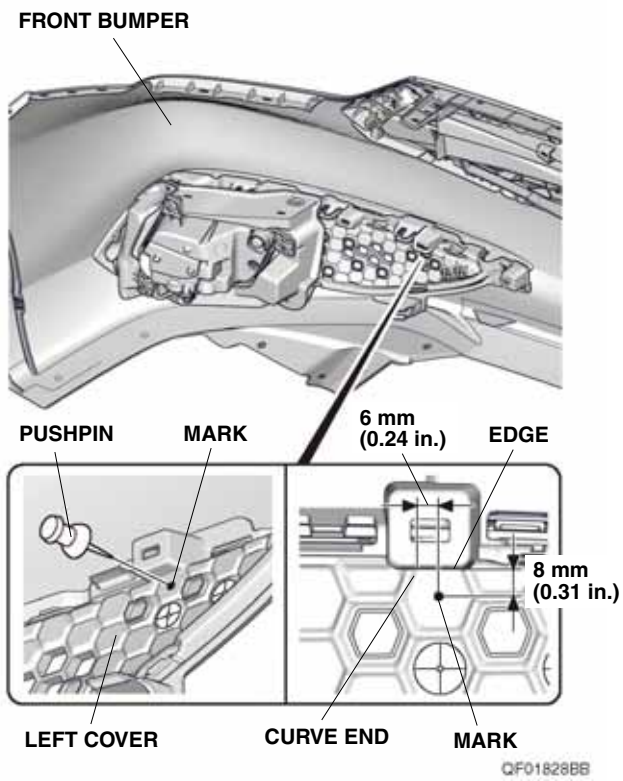

29. While wearing eye protection, drill the four pierced marks on the left cover with a 3 mm drill bit.
 NOTE: Make sure to drill perpendicular to the left cover.

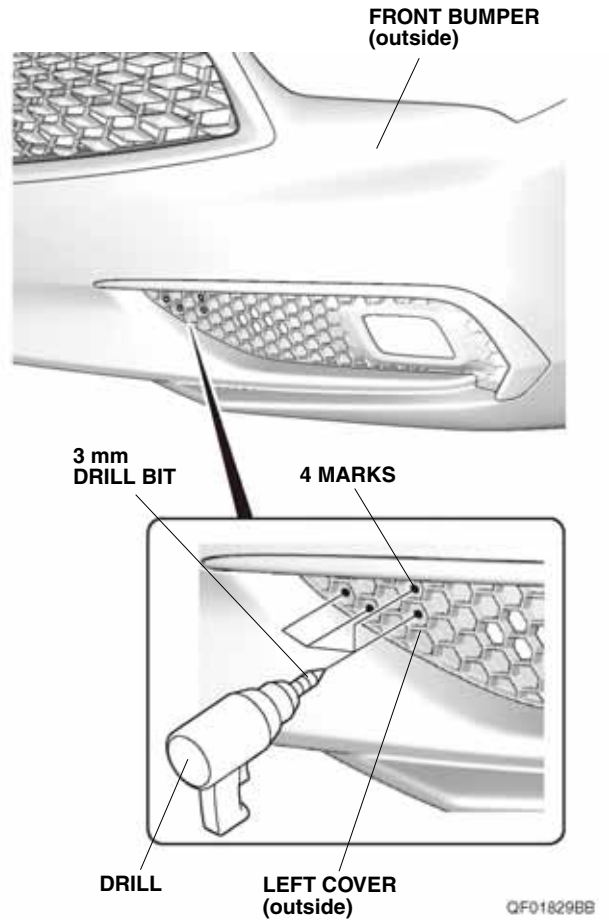

30. While wearing eye protection, enlarge the 3 mm hole on the left cover with a 5 mm drill bit. Remove any burrs.

NOTE:

- Make sure to drill the correct position.
- Make sure to drill perpendicular to the left cover.

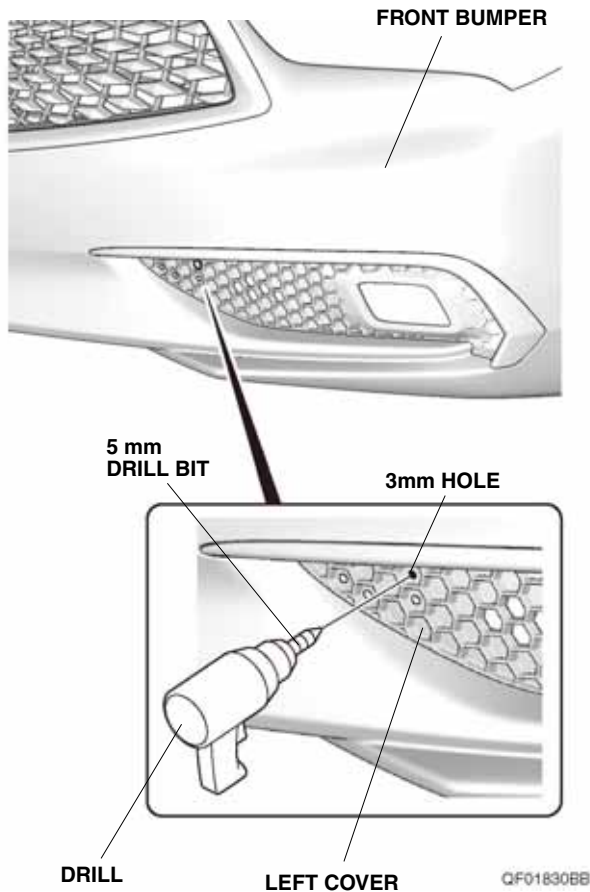

31. While wearing eye protection, enlarge the 3 mm hole on the left cover with a 28 mm hole saw. Remove any burrs.

NOTE:

- Make sure to drill the correct position.
- Make sure to drill perpendicular to the left cover.

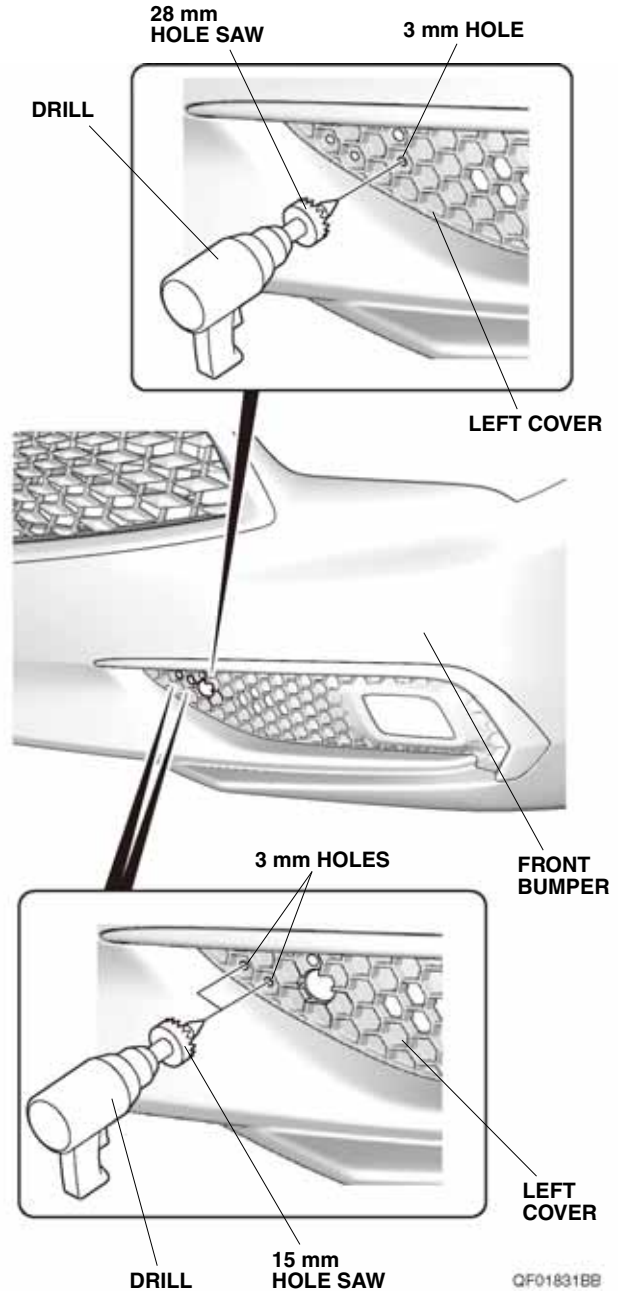

32. While wearing eye protection, enlarge two 3 mm holes on the left cover with a 15 mm hole saw. Remove any burrs.

NOTE:

- Make sure to drill the correct positions.
- Make sure to drill perpendicular to the left cover.

33. Attach the protective cap to the left cover.

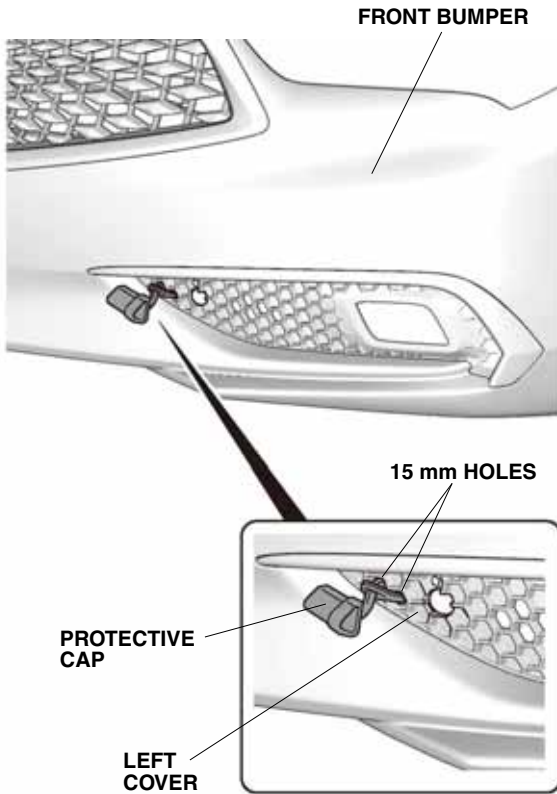

QF01832BB

34. With the help of an assistant, bring the front bumper close to the vehicle. Route the heater harness through the 28 mm hole made in step 31, then reinstall the front bumper.

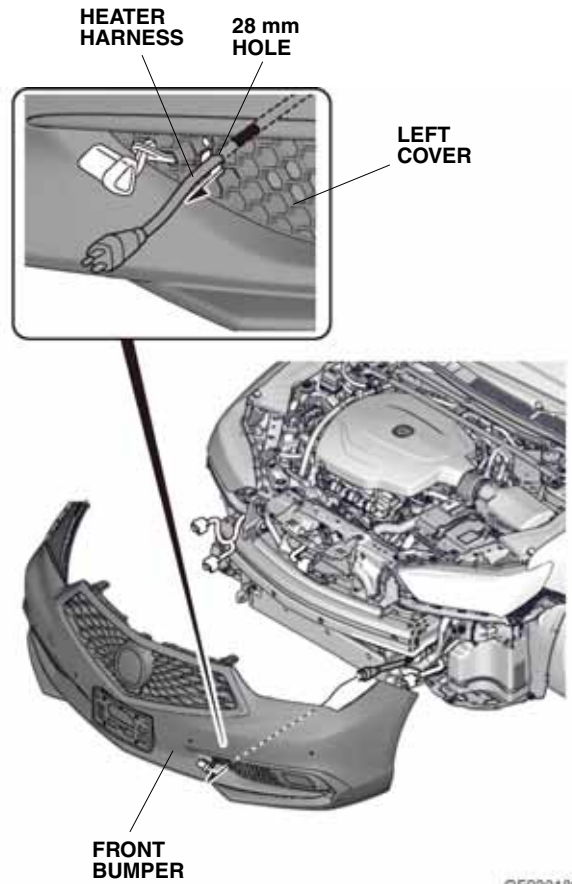

QF92018CG

35. Plug the heater harness connector into the protective cap, then secure the heater harness to the left cover with one black wire tie at point **F**.

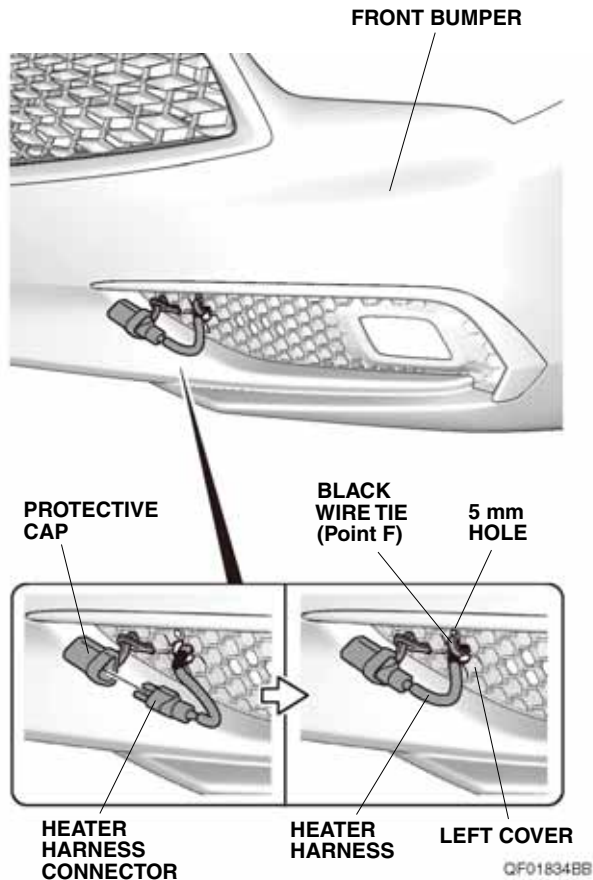

36. Install all removed parts.
37. Install the radiator drain plug.
38. Remove the radiator cap and fill the system with the recommended coolant. Follow the instructions in the service information to fill the cooling system and check for leaks. Make sure that there are no leaks around the engine block heater.
39. Make sure that the heater harness is routed properly and all connectors are plugged in.
40. Install the radiator cap.
41. Put the drain bolt (removed in step 14) in the glove box.
42. Connect the negative cable to the battery.
43. Press and hold the audio unit power button for 2 seconds to restore audio and navi (if equipped) system functions.
44. Set the clock on vehicles without navigation.
45. If necessary, restore the systems back to normal operation as described in the service information.