

PARTS LIST

Cargo hook



Bolt



Small washer



Spring washer



Rivet nut



Large washer



Flange nut
(Not used)



Accessory User's Information Manual



TOOLS AND SUPPLIES REQUIRED

Pushpin

Drill

3 mm Drill bit

32 mm Hole saw

Felt-tip pen

Eye protection (face shield, safety goggles, etc.)

Hex wrench

19 mm Open end wrench

10 mm Socket

Ratchet

Torque wrench

The following tools are available through the Acura Tool and Equipment Program. On the iN, click on: Service > Service Bay > Tool and Equipment Program, then enter the number under "Search." Or, call 888-424-6857.

- Trim Tool Set (T/N SOJATP2014)

- Rivet Nut Tool, 6 mm (T/N 07AAE-000A100)

Illustration of the Cargo Hook in the Vehicle



INSTALLATION

Client Information: The information in this installation instruction is intended for use only by skilled technicians who have the proper tools, equipment, and training to correctly and safely add equipment to your vehicle. These procedures should not be attempted by “do-it-yourselfers.”

NOTE: Be careful not to damage the body.

1. Open the trunk. Pull away the weatherstrip, and remove the six clips from the trunk upper trim panel.

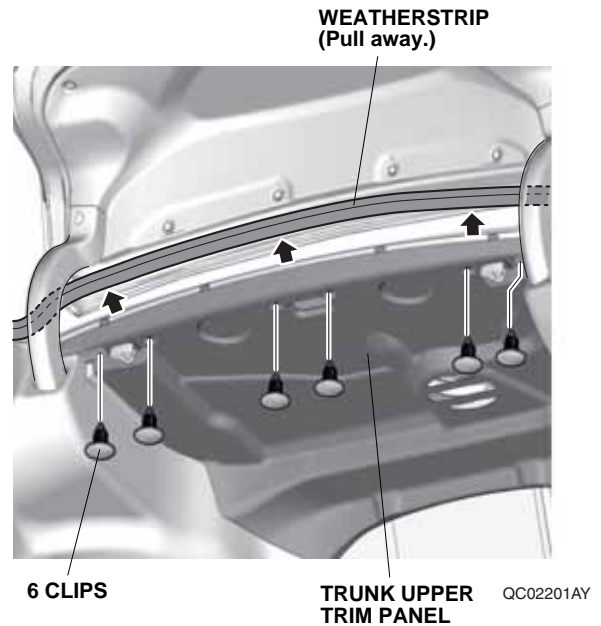

2. Pull down the trunk upper trim panel. Push the tab, then pull down the right seat-back release lever to release the hook and remove the lever. Remove the left seat-back release lever the same way.

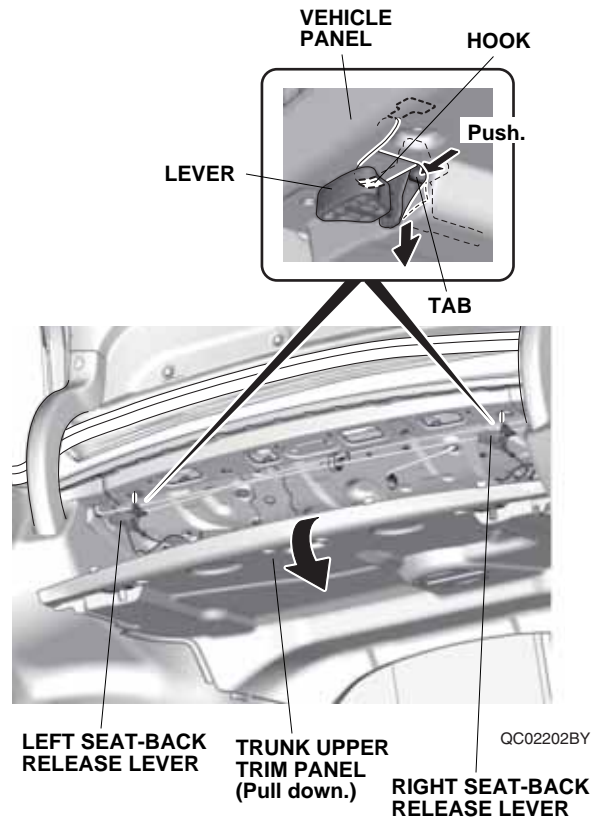

- Thread the rivet nut onto the mandrel of the 6 mm rivet nut tool as shown.

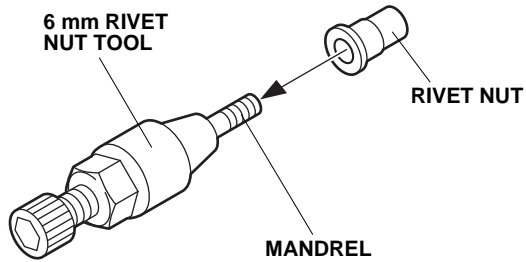

6D26010E

- Insert the rivet nut into the hole in the vehicle panel, and install the hex wrench on the rivet nut tool.

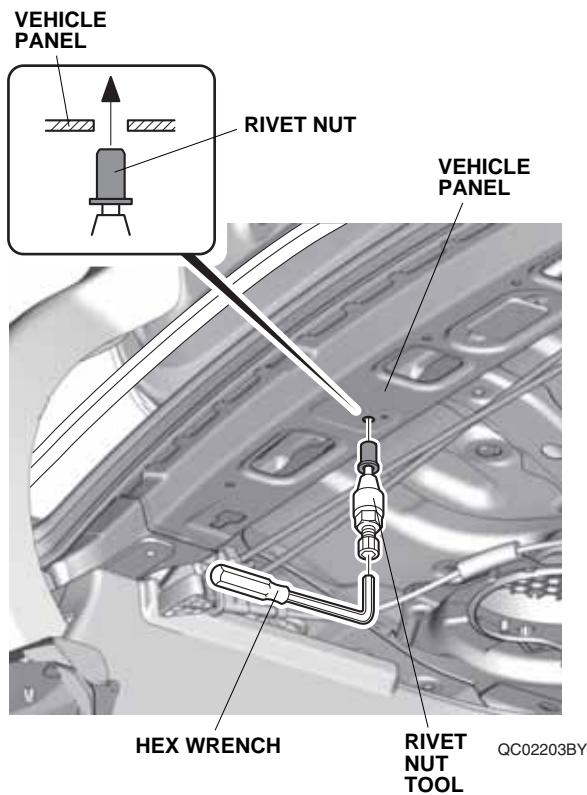

QC02203BY

- While holding the rivet nut tool with the hex wrench, use a 19 mm open end wrench to rotate the tool counterclockwise.

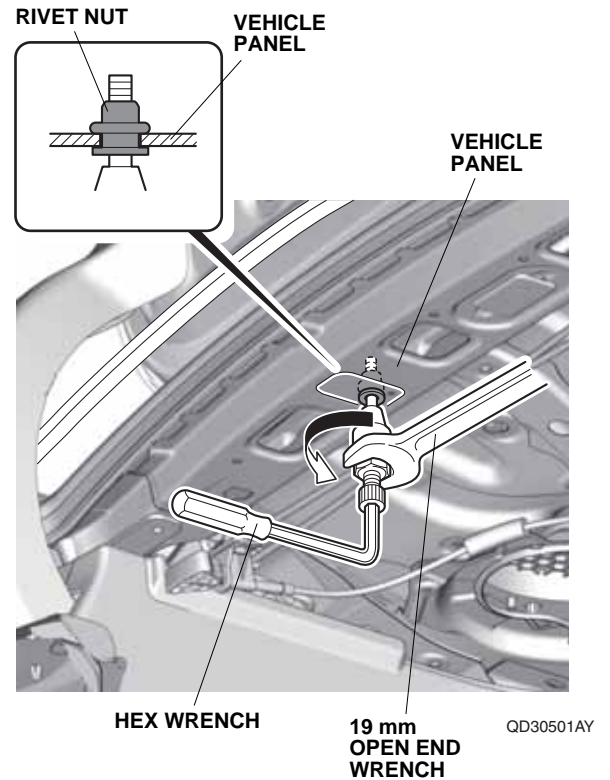

QD30501AY

- Remove the rivet nut tool from the rivet nut by turning the hex wrench counterclockwise.

7. Using a felt-tip pen, mark the trunk upper trim panel as shown.

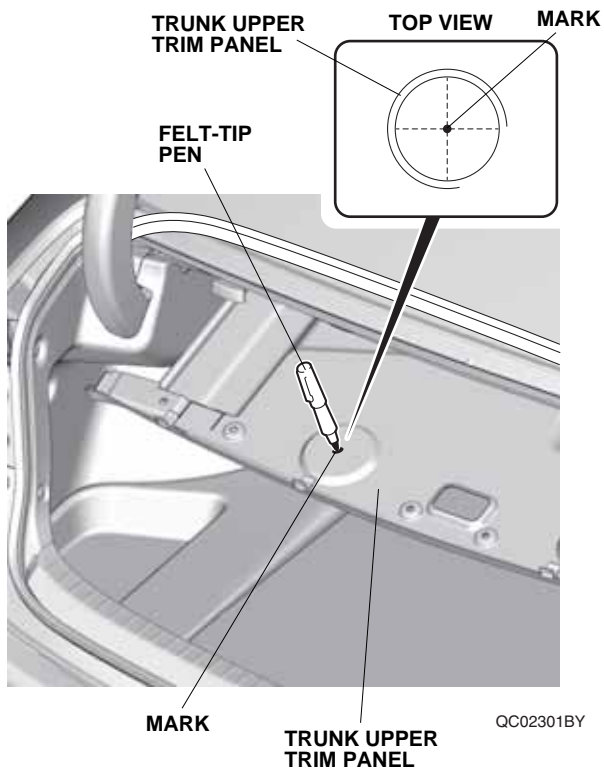

8. Using a pushpin, pierce the trunk upper trim panel at the mark made in step 7.

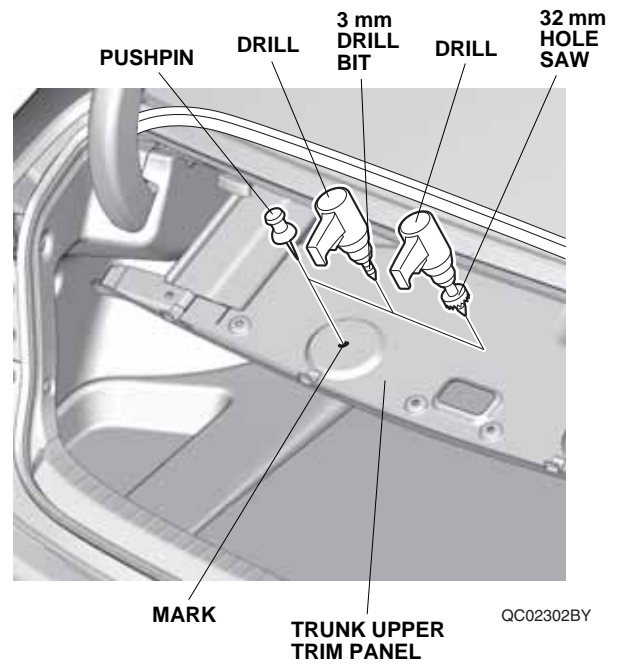

9. While wearing eye protection, drill the pierced mark in the trunk upper trim panel to 32 mm. First drill with a 3 mm drill bit, and finish with a 32 mm hole saw. Remove any burrs.
10. Reinstall the seat-back release levers and the trunk upper trim panel.

11. Align the cargo hook pin with the hole in the vehicle panel, and secure the hook to the vehicle panel using the bolt, large washer, spring washer, and small washer. Torque the bolt to 4.0 N·m (3.0 lb·ft).

