



# INSTALLATION INSTRUCTIONS

Accessory  
**BACKUP SENSORS**

Application  
**2018 RDX**

Publications No.  
**VERSION 1**  
Issue Date  
**MAY 2017**

## PARTS LIST

### Backup Sensors Attachment Kit P/N 08V67-TX4-200

Control unit

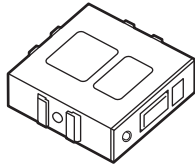

Control unit bracket

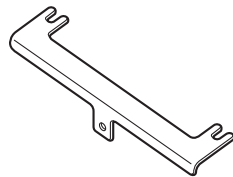

Buzzer

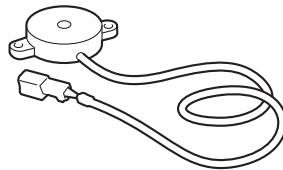

Backup sensor harness

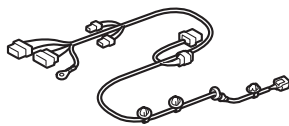

Subharness

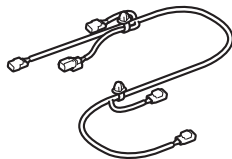

Right sensor clip (White)

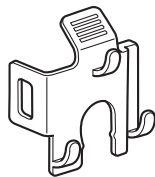

Left sensor clip (Black)

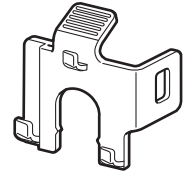

2 Center sensor clips (Yellow)

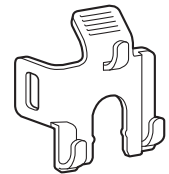

12 Wire ties

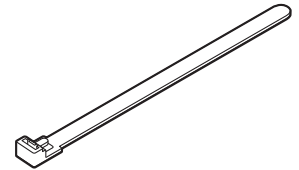

3 Aluminum tapes

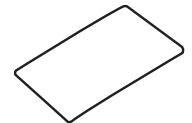

Fuse label



Clip



Switch

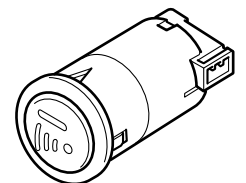

Narrow wire tie

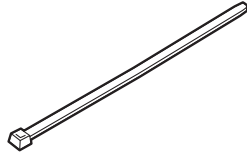

Switch bracket

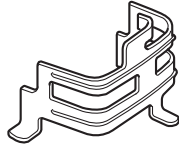

Ground bolt  
(May not be used)



Accessory User's Information Manual

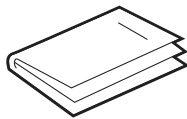

**Backup Sensors Kit  
P/N 08V67-TX4-200J**

Left corner sensor

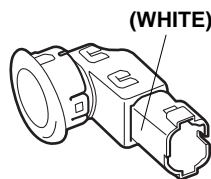

Right corner sensor

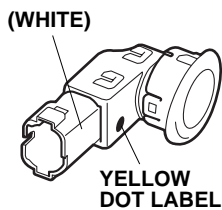

2 Center sensors

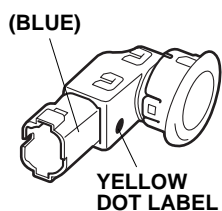

**TOOLS AND SUPPLIES REQUIRED**

- Phillips screwdriver
- Small flat-tip screwdriver
- 10 mm Open end wrench
- 10 mm Socket
- Pushpin
- Ratchet
- 3 mm Drill bit
- Eye protection (face shield, safety goggles, etc.)
- File
- Ruler
- Blanket
- Isopropyl alcohol
- Shop towel
- Rubber mallet
- 24 mm and 26 mm Hole saws
- Drill
- Diagonal cutters
- Masking tape
- Hex wrench

*The following tool is available through the Acura Tool and Equipment Program. On the iN, click on Service > Service Bay > Tool and Equipment Program, then enter the number under "Search." Or, call 888-424-6857.*

Trim Tool Set (T/N SOJATP2014)

**Illustration of the Backup Sensors on the Vehicle**

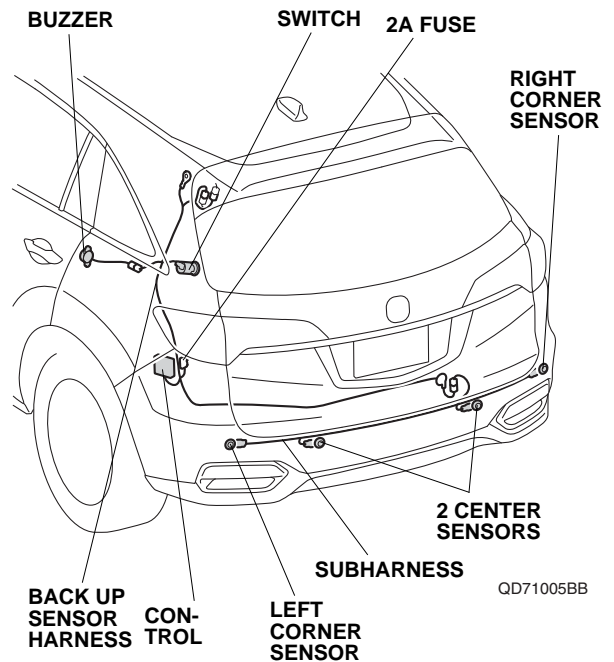

## INSTALLATION

**Client Information:** The information in this installation instruction is intended for use only by skilled technicians who have the proper tools, equipment, and training to correctly and safely add equipment to your vehicle. These procedures should not be attempted by “do-it-yourselfers.”

NOTE: Refer to Parts Information Bulletin (PIB) for the proper color sensors.

1. Disconnect the negative cable from the battery.
2. Remove the cargo floor board.

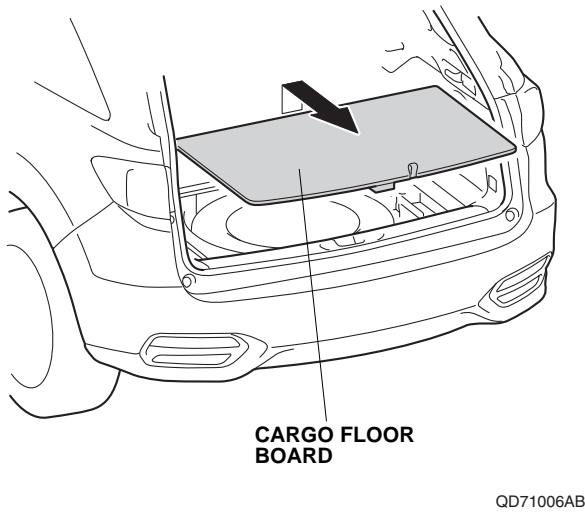

3. Remove the front cargo floor lid.

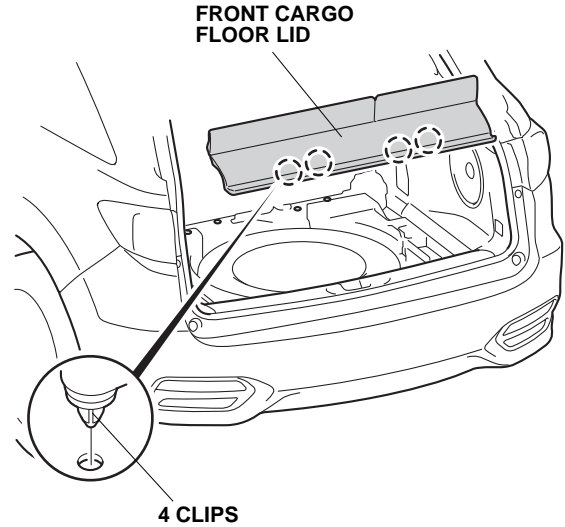

4. Pull away the weatherstrip.

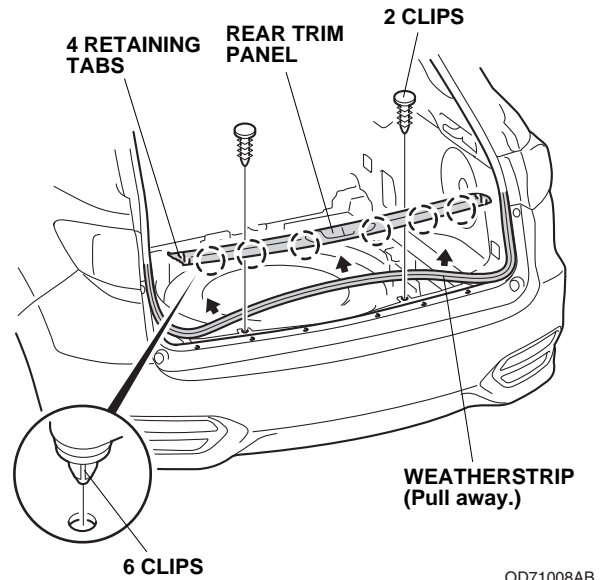

5. Remove the rear trim panel.

6. Remove the rear seat cushion.

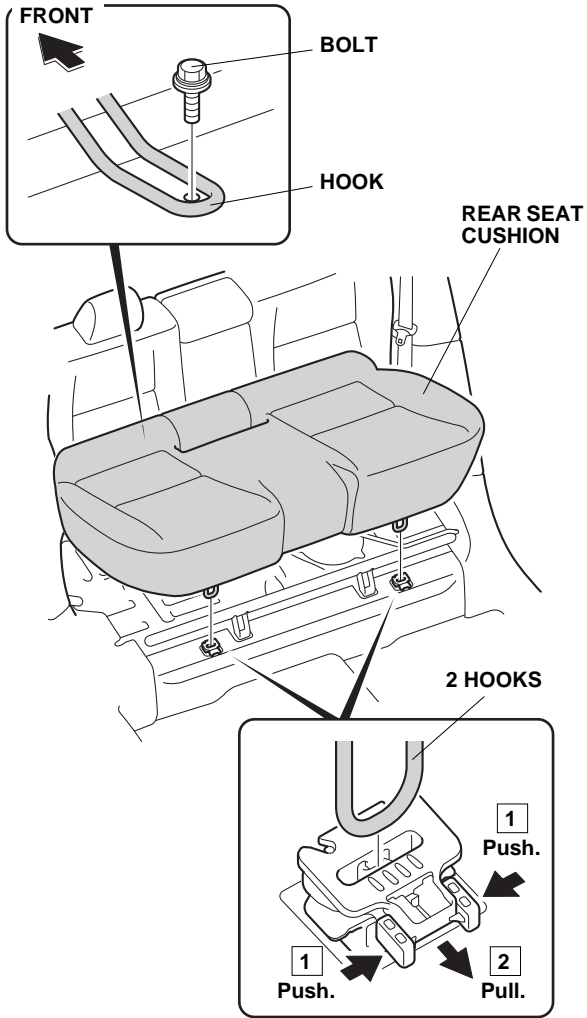

QB10701BB

7. Remove the left rear side trim.

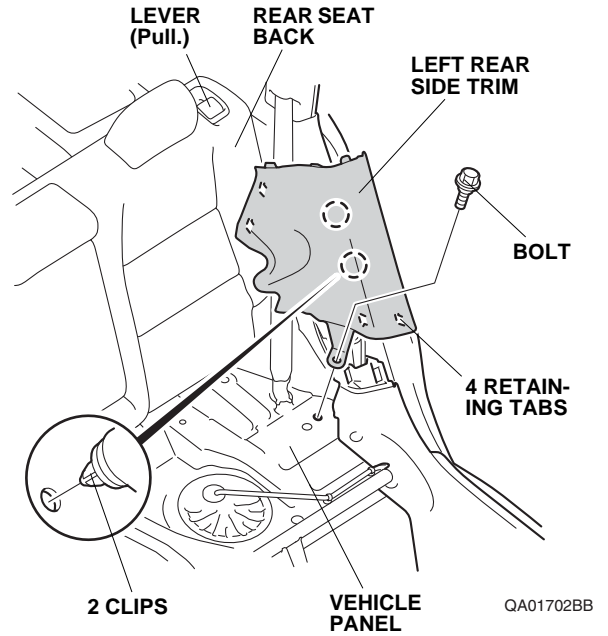

8. Pull the lever, and fold down the rear seat back.

9. Pull away the weatherstrip from around the left rear side trim panel at the tailgate, and pull away the door opening seal at the left rear door.

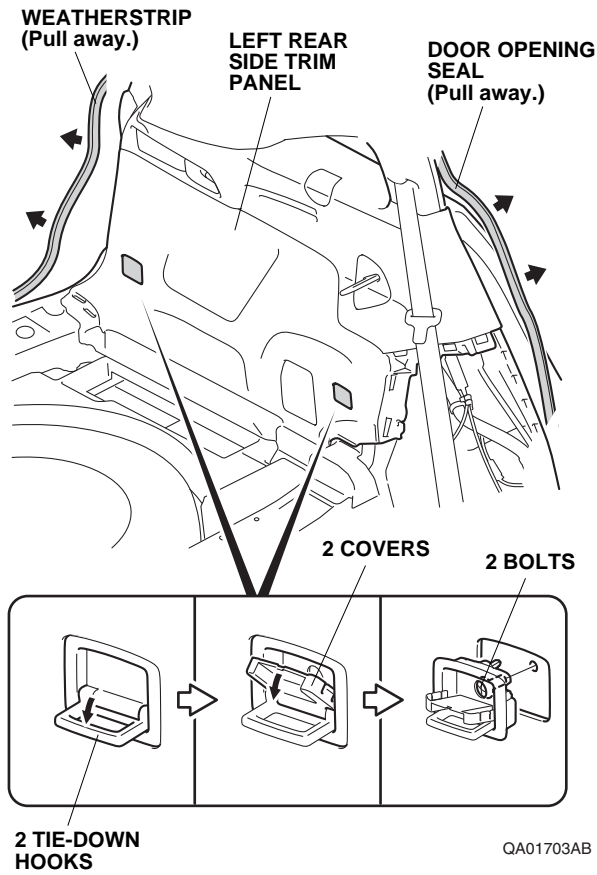

10. Using an impact screwdriver, remove the two tie-down hooks.

11. Gently pull the lever on the left rear side trim panel, and use a small flat-tip screwdriver wrapped with a shop towel, remove the inner handle cap.

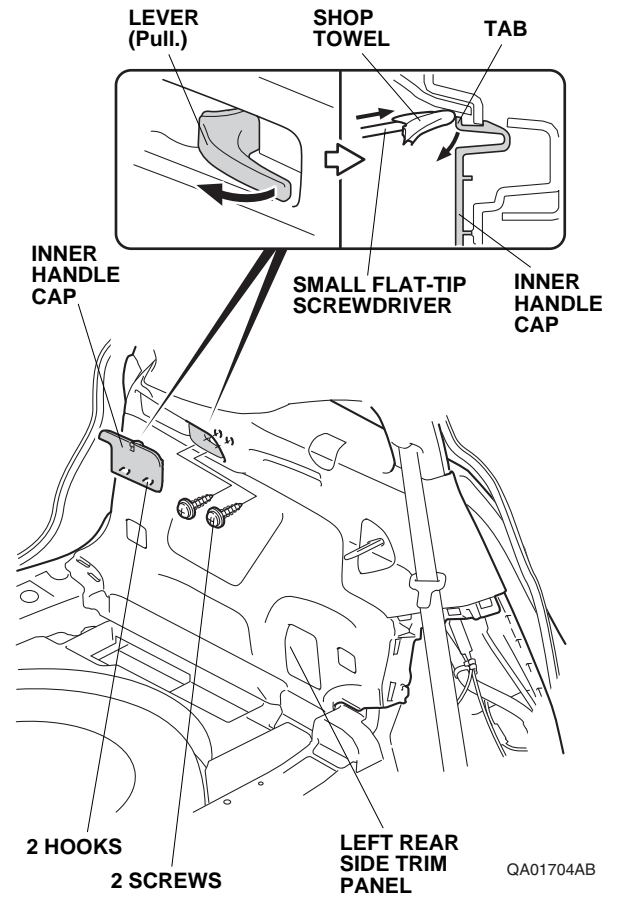

12. Remove the two screws.

13. Starting at the front, release the left rear side trim panel.

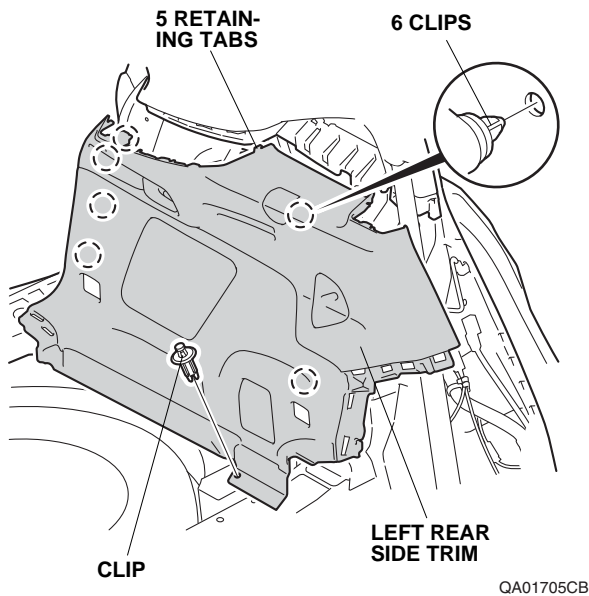

14. Release the wire and remove the lever, then remove the left rear side trim panel.

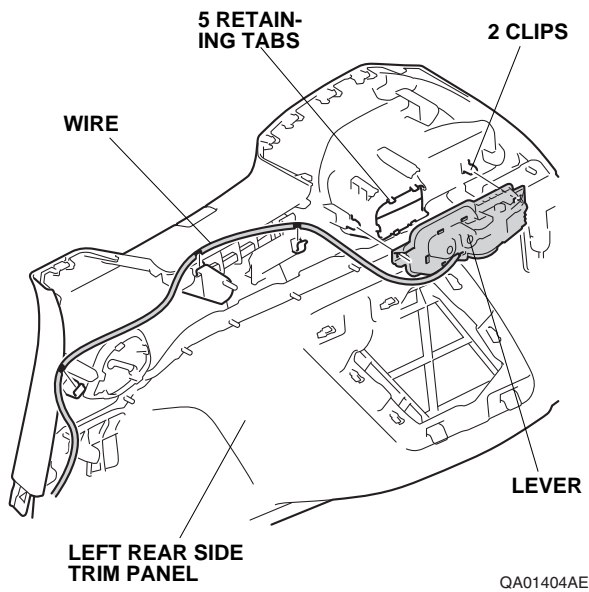

15. Remove the left spacer.

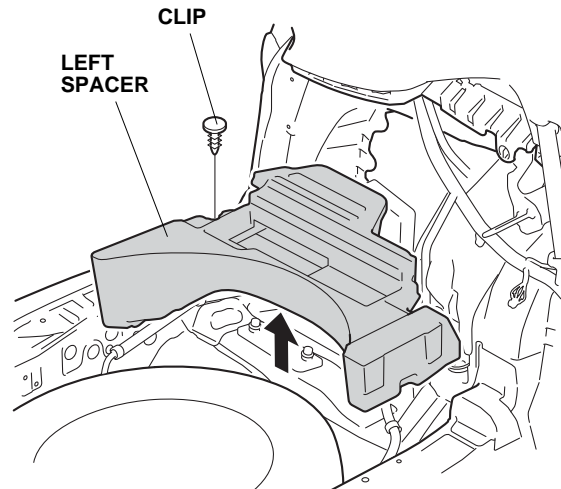

QA01706BB

16. Using a rubber mallet wrapped with a shop towel, lightly tap the area marked "SIDE CURTAIN AIRBAG" on the left quarter pillar trim to push in the clip. Make sure to strike area perpendicularly to the vehicle.

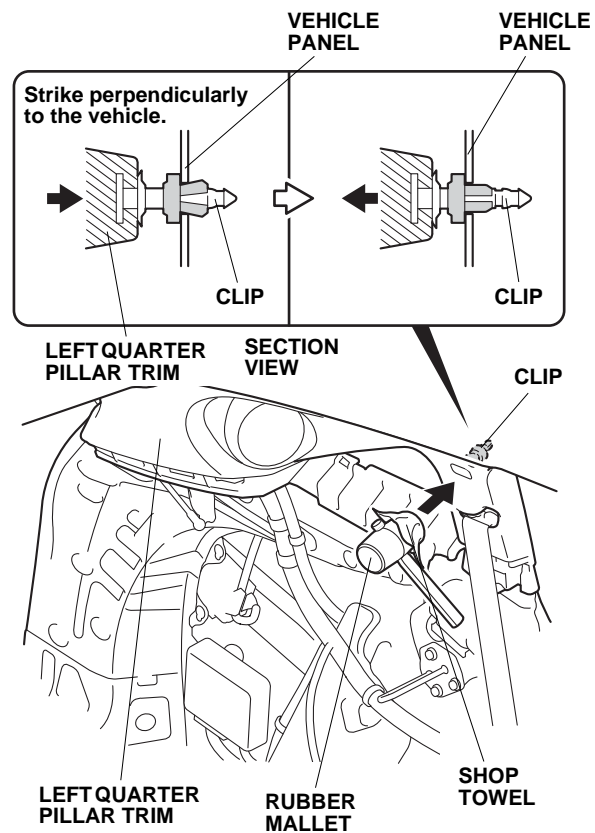

17. Remove the left quarter pillar trim.

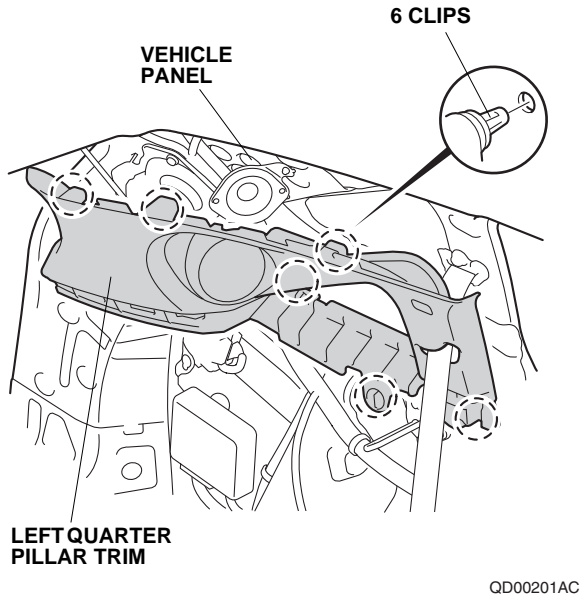

18. Remove the rear bumper.

- On each side of the vehicle, attach masking tape to the rear bumper, taillight, and rear fender as shown.

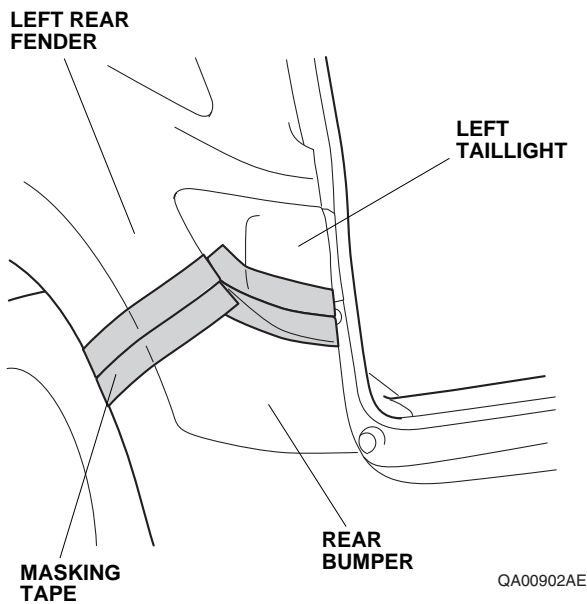

- Remove two covers, two bumper screws, two bolts, four self-tapping screws, and six clips.

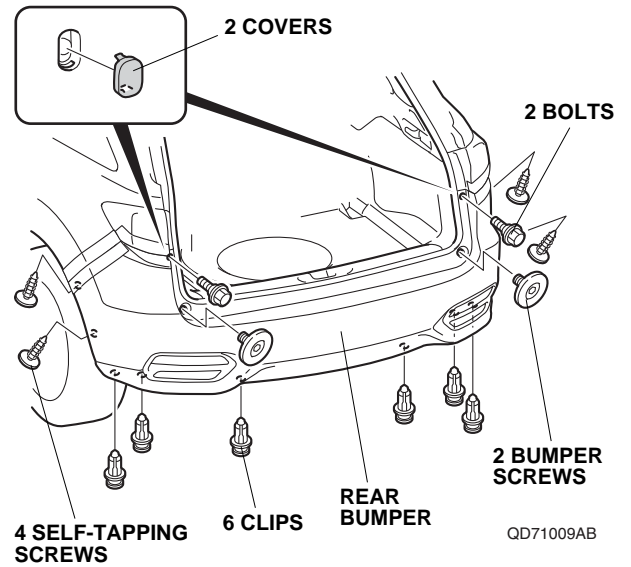

- Release six retaining tabs on each side of the bumper.

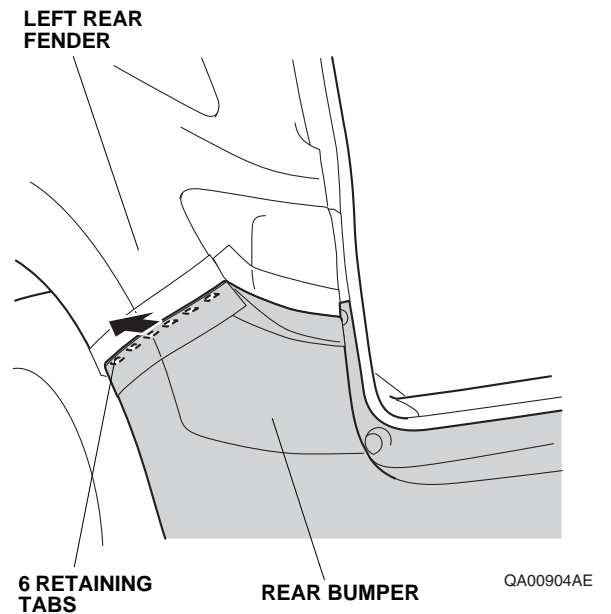

- Release one retaining tab on each side of the bumper.

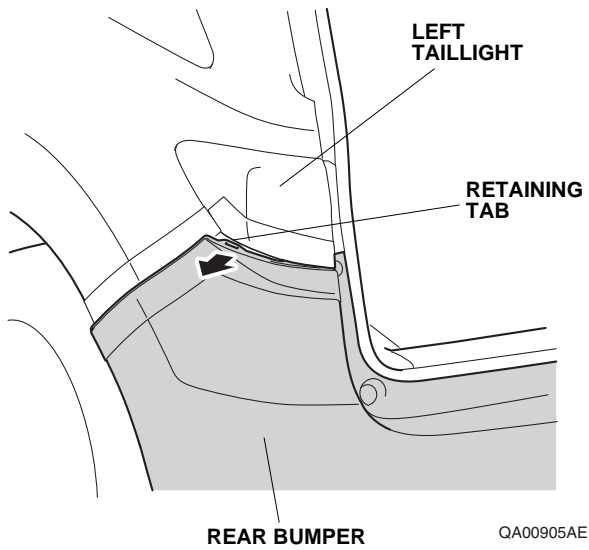

- With the help of an assistant, remove the rear bumper.
- Place the rear bumper on a blanket.

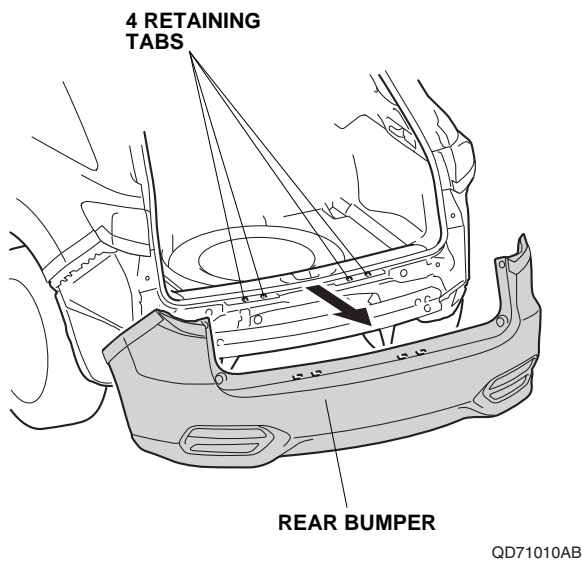

19. Install the control unit bracket to the control unit.

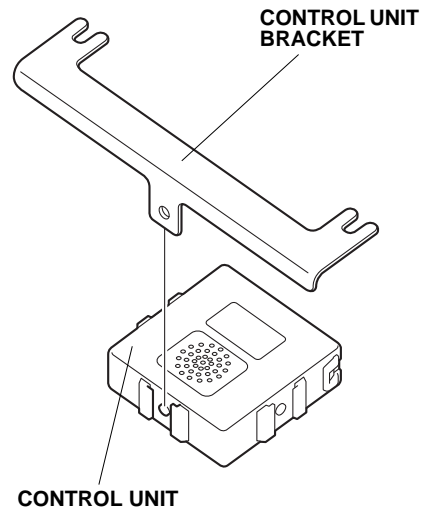

QD71011AB

20. Loosen the two vehicle bolts from the vehicle panel, and install the control unit bracket between the vehicle panel and vehicle unit bracket with the two vehicle bolts just loosened.

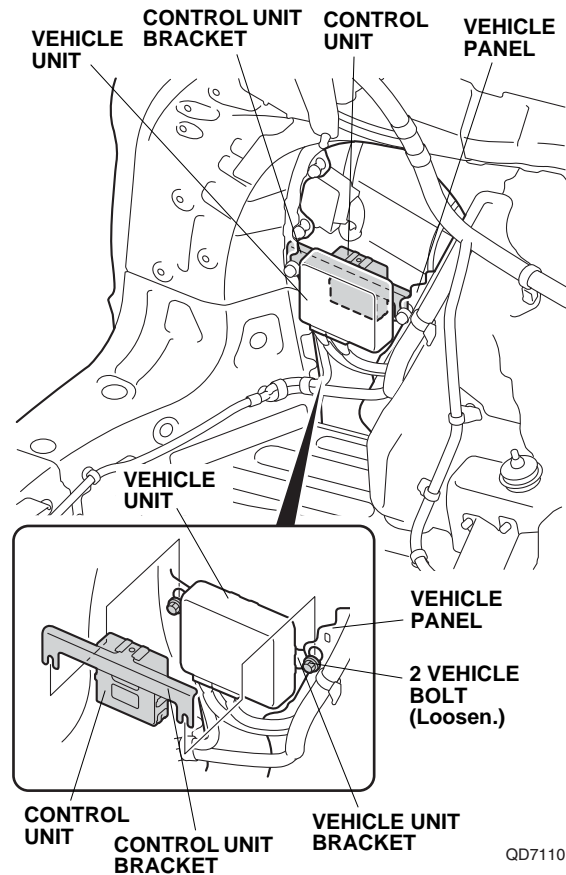



- Using isopropyl alcohol on a shop towel, thoroughly clean the fuse case where the fuse label will attach. Attach 2A fuse label to the fuse case on the backup sensor harness.

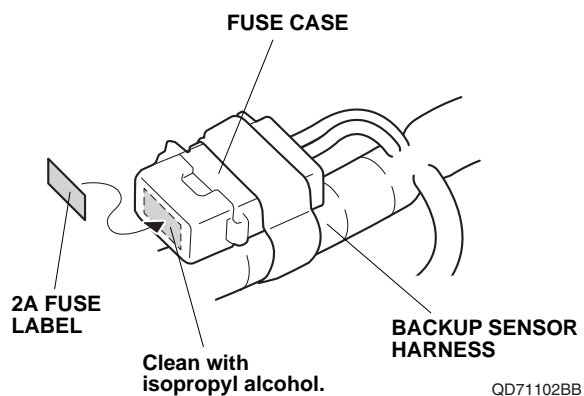

- Unplug the vehicle harness 20-pin connector, and plug it into the backup sensor harness 20-pin connector. Plug the remaining backup sensor harness 20-pin connector into the vehicle 20-pin connector.

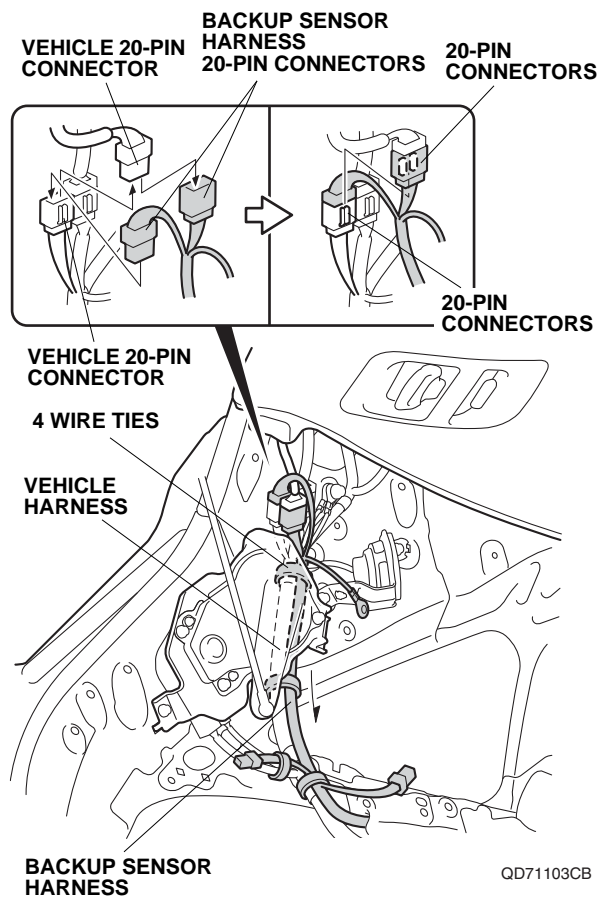

- Secure the backup sensor harness to the vehicle harness with four wire ties.

24. Remove the vehicle ground bolt.

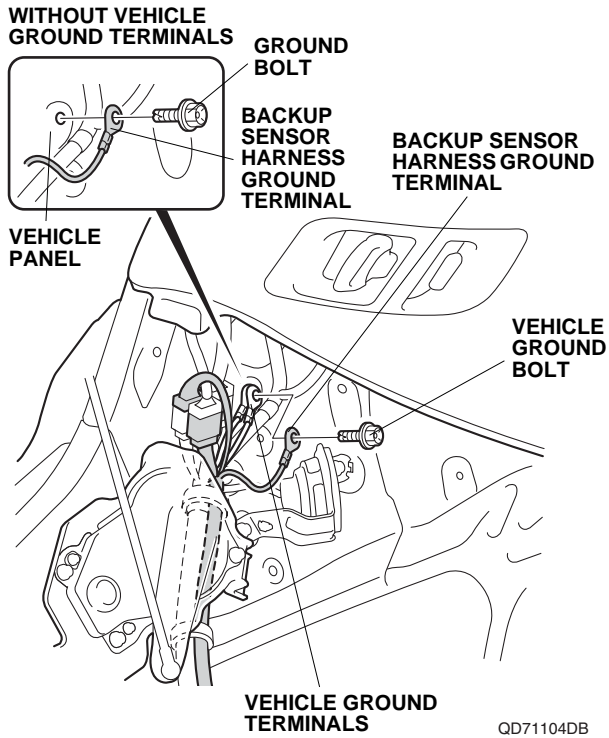

25. Secure the backup sensor harness ground terminal to the vehicle ground terminals with the vehicle ground bolt just removed. Do not put the ground terminal calkings on top of one another.

26. Using isopropyl alcohol on a shop towel, thoroughly clean the vehicle panel where the buzzer will attach.

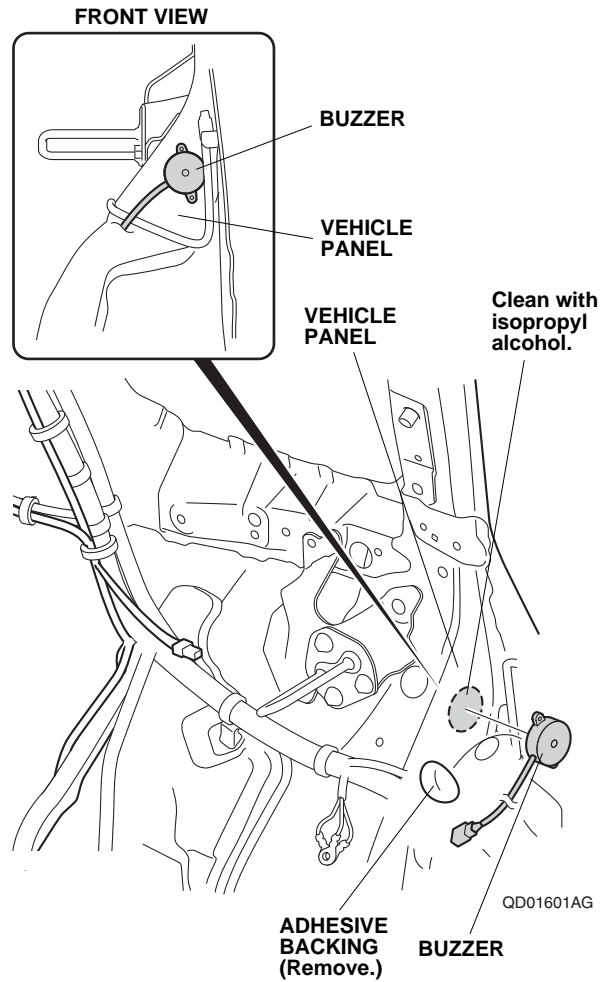

27. Remove the adhesive backing from the buzzer and attach the buzzer to the vehicle panel in the location shown.

28. Plug the backup sensor harness 2-pin connector into the buzzer 2-pin connector.

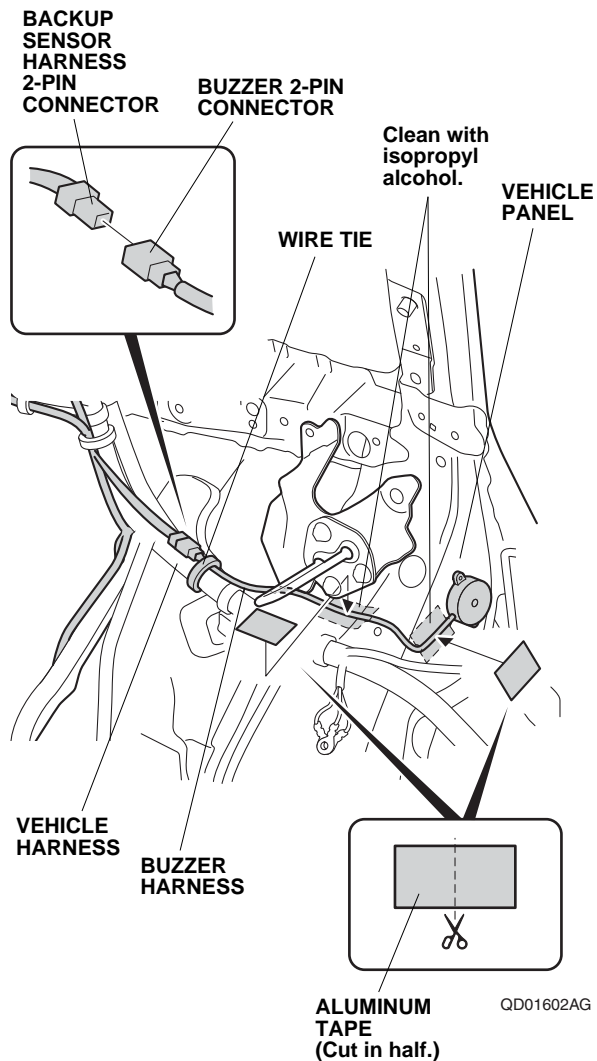

29. Using isopropyl alcohol on a shop towel, thoroughly clean the vehicle panel where the aluminum tapes will attach.
30. Using scissors, cut one aluminum tape in half. Secure the buzzer harness to the vehicle panel and the vehicle harness with the two cut pieces of aluminum tape and one wire tie.

31. Route the backup sensor harness down along the vehicle harness, and secure the backup sensor harness to the vehicle harness with three wire ties.

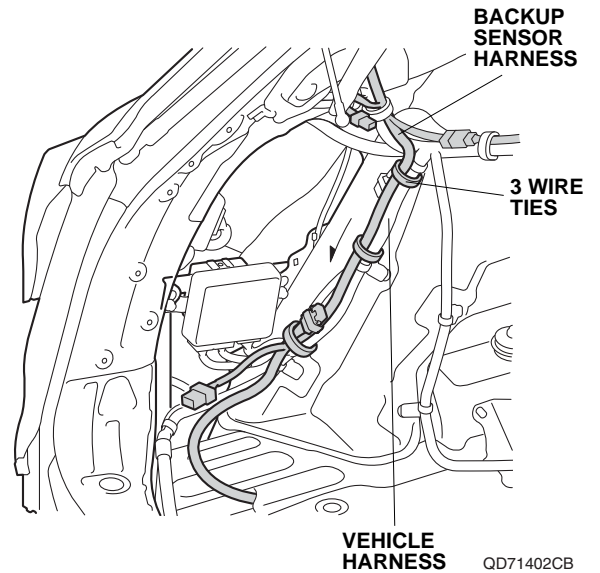

32. Plug the backup sensor harness 14-pin connector into the control unit.

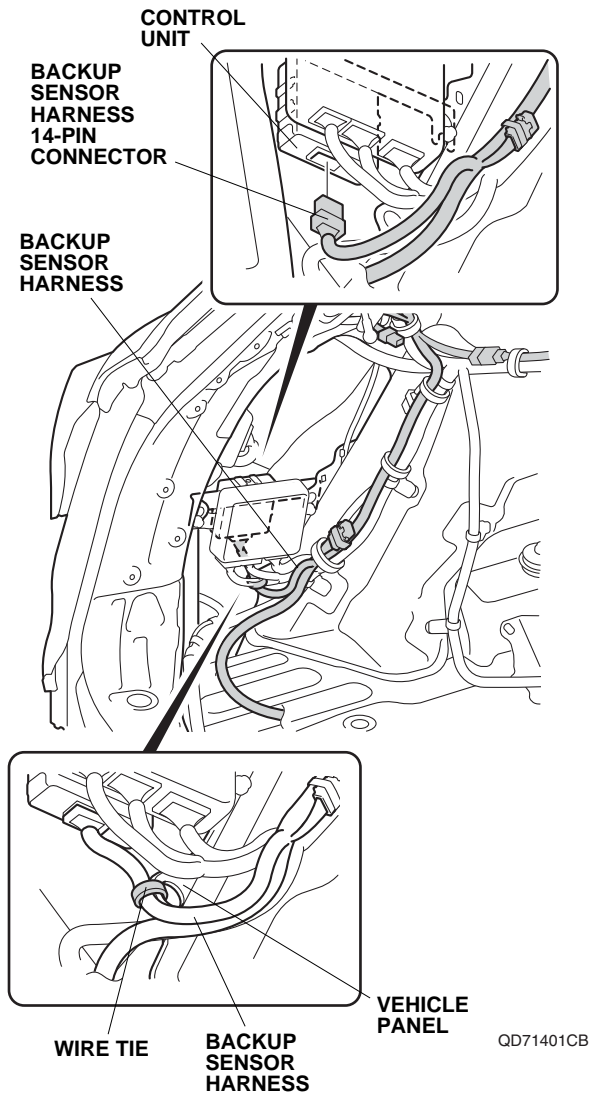

33. Secure the backup sensor harness to the vehicle panel and vehicle harness with one wire tie.

34. Locate and remove the vehicle grommet from the vehicle panel.

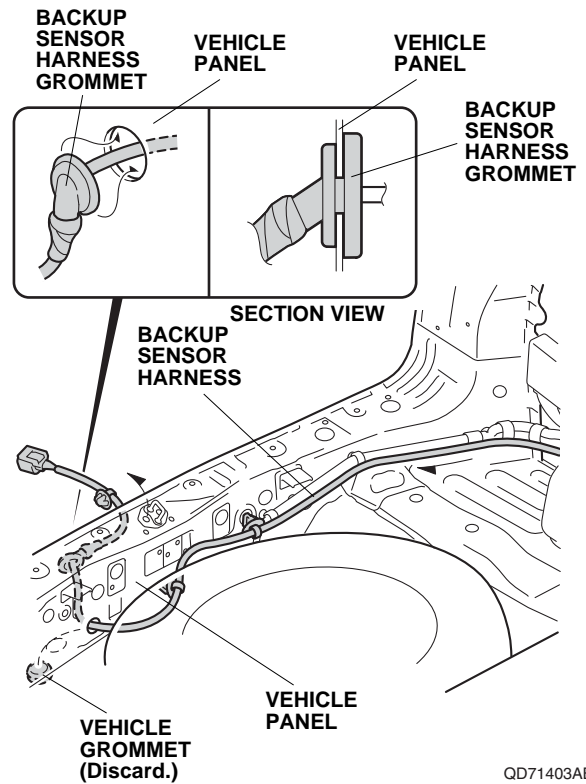

35. Route the backup sensor harness through the hole, and seat the grommet on the backup sensor harness in the vehicle panel hole.  
NOTE: Do not pull on the backup sensor harness when installing the grommet.

36. Secure the backup sensor harness to the vehicle panel and vehicle harness with two clips on the backup sensor harness, and three wire ties as shown.

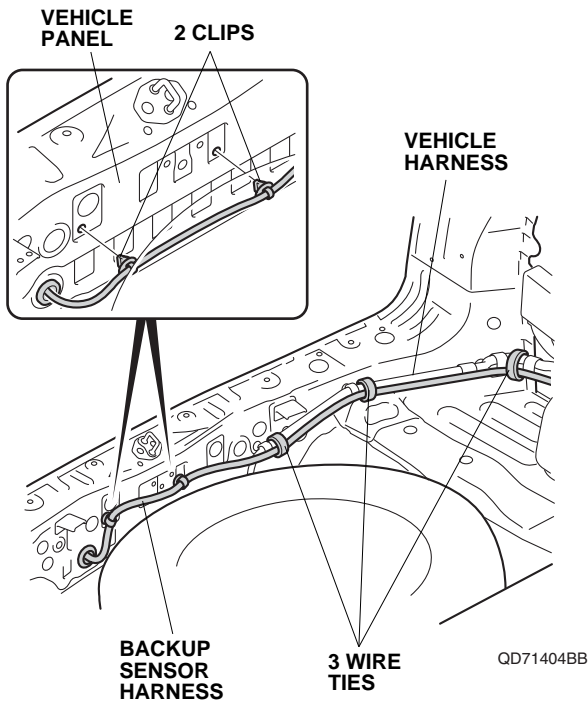

37. Secure the backup sensor harness to the vehicle panel with two clips on the backup sensor harness.

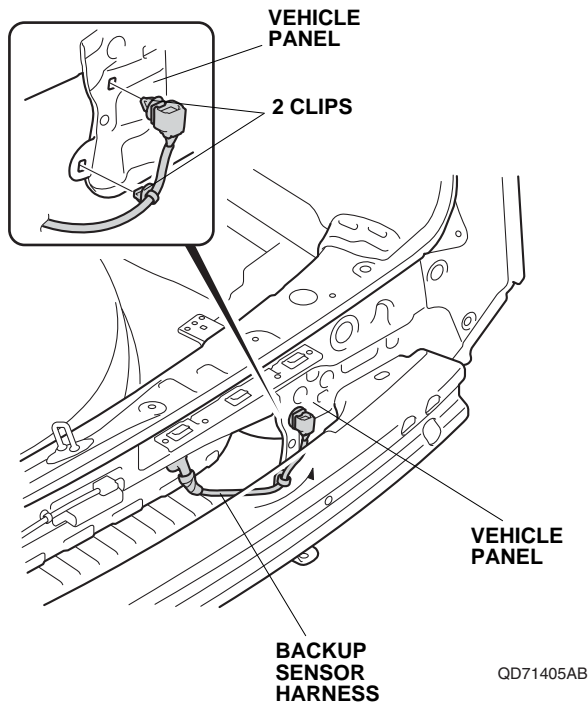

38. Using a pushpin, pierce the left rear side trim panel at the location shown.

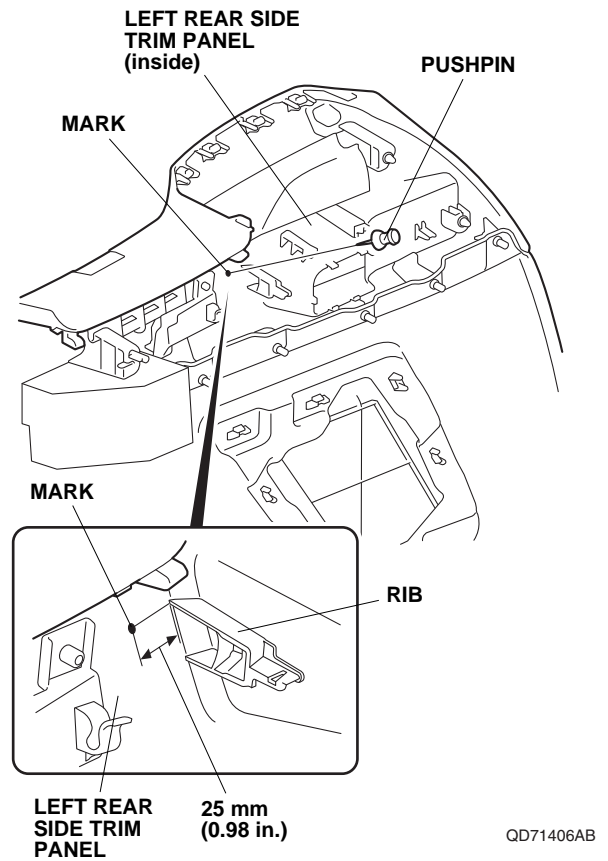

39. While wearing eye protection, drill the pierced mark on the left rear side trim panel with a 3 mm drill bit. Then enlarge the 3 mm hole to 26 mm using a 26 mm hole saw.   
**NOTE:** Make sure to drill perpendicularly to the left rear side trim panel. Remove any burrs.

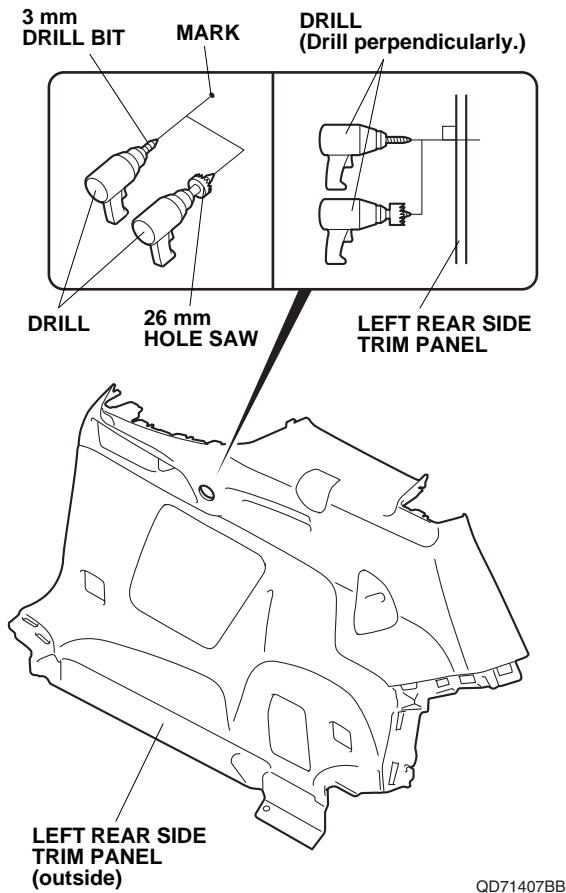

40. Install the switch into the 26 mm hole in the left rear side trim panel.   
**NOTE:** Make sure the switch is inserted in the correct orientation.

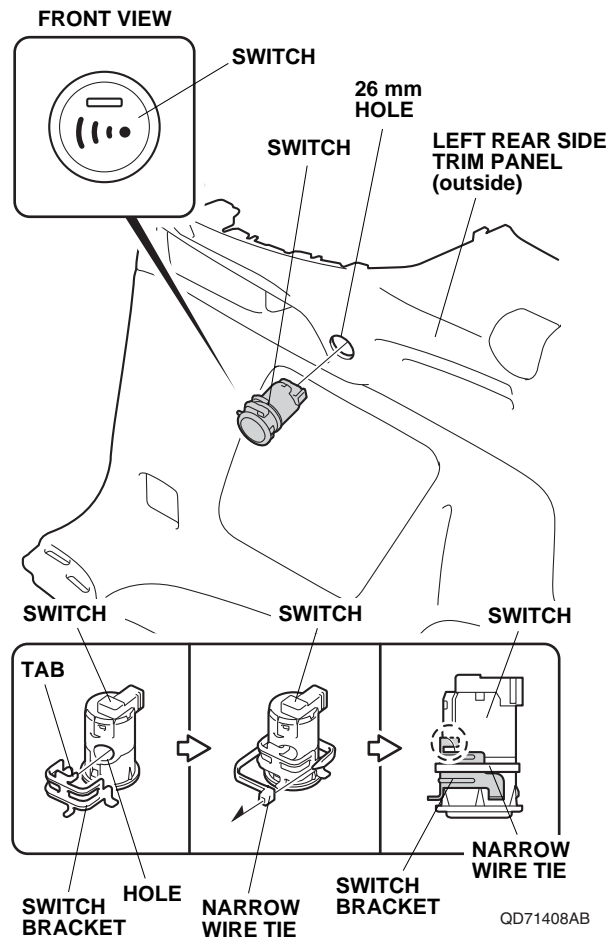

41. Align the tab on the switch bracket with the hole on the switch and secure the switch bracket to the switch with one narrow wire tie.   
**NOTE:** Firmly press the switch bracket against the left rear side trim panel, and make sure that there is no clearance between the switch and left rear side trim panel.

42. Remove and discard the vehicle clip.

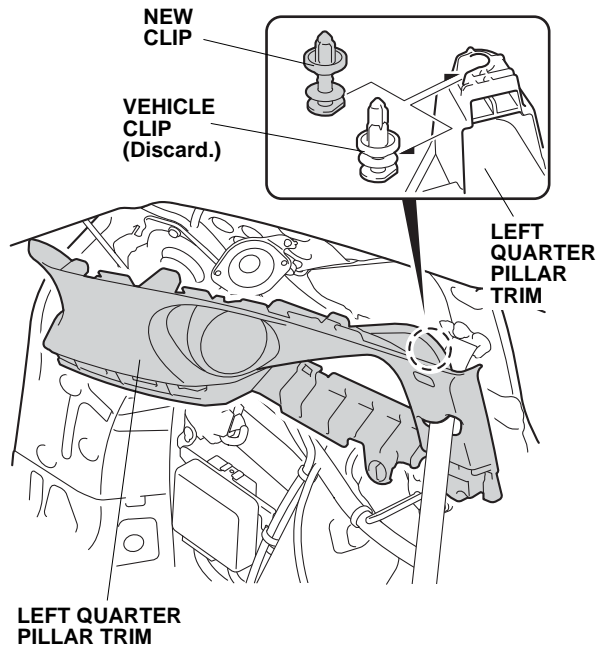

QD71409BB

43. Check the overlap between the headliner and the quarter pillar trim, and install the new clip to the left quarter pillar trim.  
**NOTE:** Check and adjust the overlap as described in the Service Manual.
44. Reinstall the left quarter pillar trim.  
**NOTE:** Make sure the side curtain airbag is not tucked under the clip. Do not push the quarter pillar trim excessively.

45. Bring the left rear side trim panel into position. Plug the backup sensor harness 3-pin connector into the switch, and reinstall the lever and the left rear side trim panel.

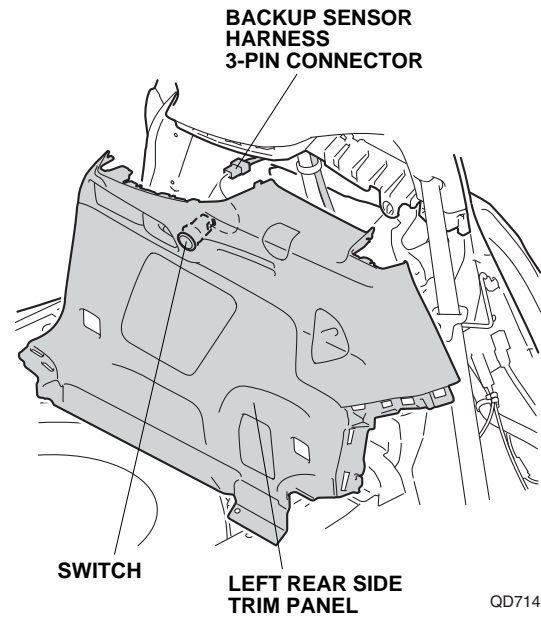

QD71410AB

46. Mark the inside of the rear bumper:

- Locate the two scribe marks on the inside of the rear bumper at the center and right side.
- Using a pushpin, pierce the rear bumper at the top and center of the two scribe marks.  
NOTE: There are several markings on the inside of the rear bumper. Before piercing the rear bumper, verify you have the correct locations.  
NOTE: Make sure to pierce the scribe marks perpendicularly to the rear bumper.

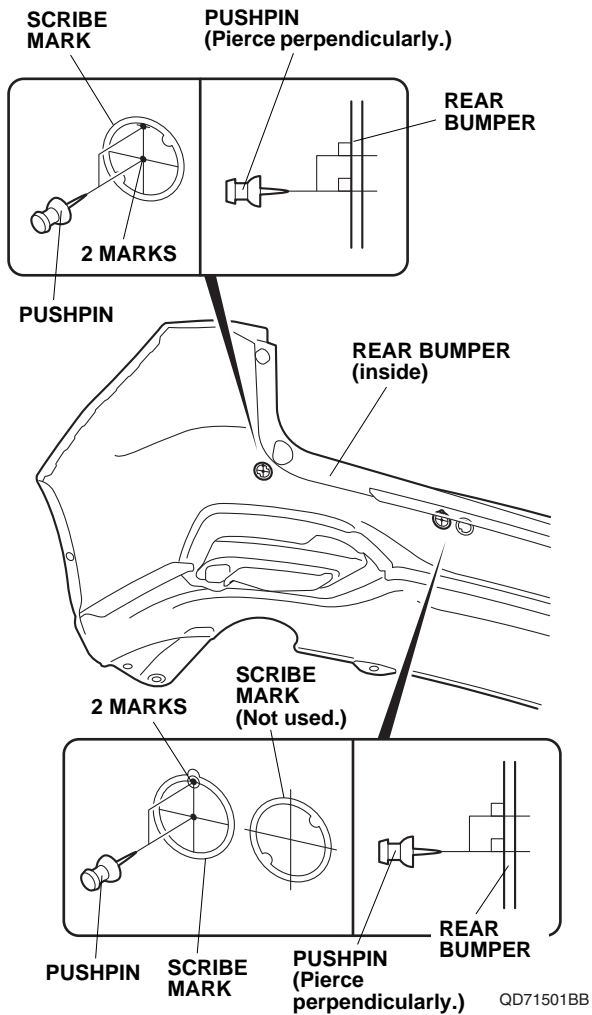

47. Mark the inside of the rear bumper:

- Locate the two scribe marks on the inside of the rear bumper at the center and left side.
- Using a pushpin, pierce the rear bumper at the top and center of the two scribe marks.  
NOTE: There are several markings on the inside of the rear bumper. Before piercing the rear bumper, verify you have the correct locations.  
NOTE: Make sure to pierce the scribe marks perpendicularly to the rear bumper.

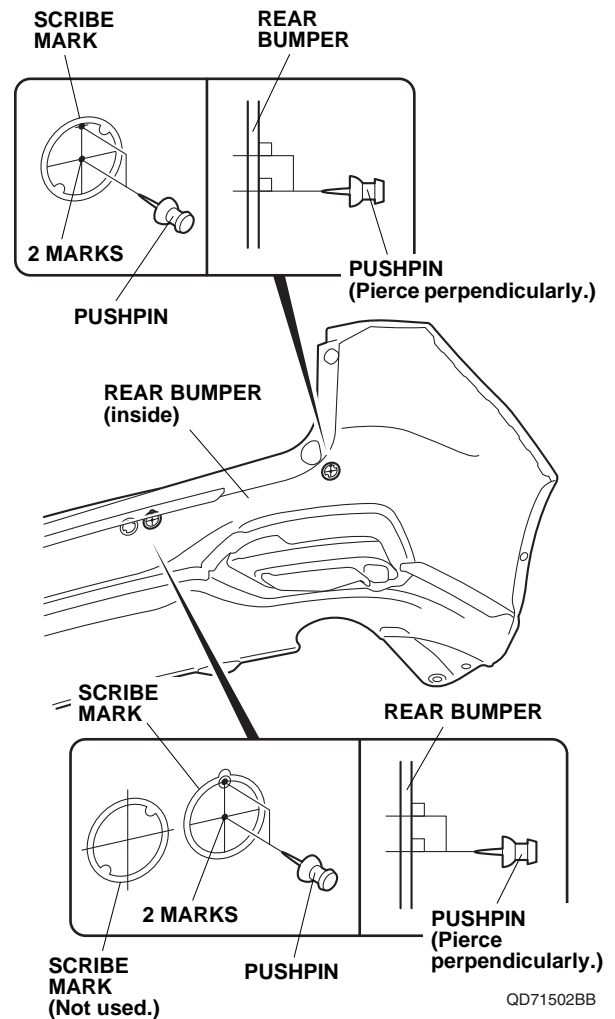



48. While wearing eye protection, drill the eight pierced marks with a 3 mm drill bit from the painted side of the rear bumper.
- NOTE: Make sure to drill perpendicularly to the rear bumper.

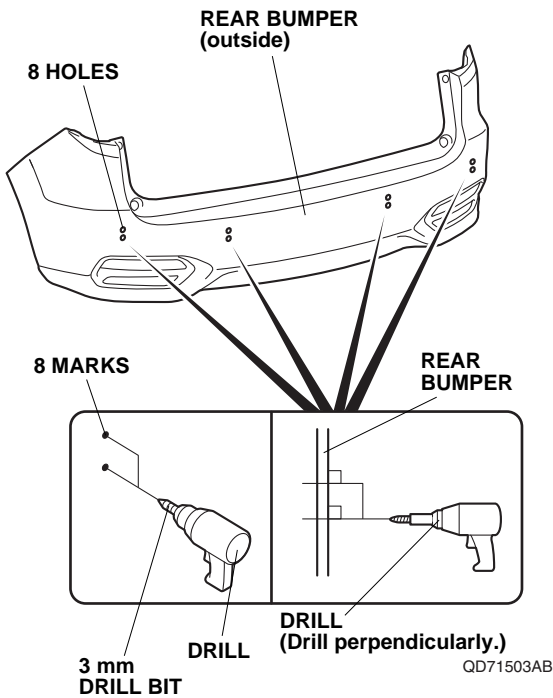

49. While wearing eye protection and drilling from painted side of the rear bumper, enlarge the two lower 3 mm outer holes to 24 mm using a 24 mm hole saw.
- NOTE: Make sure to drill perpendicularly to the rear bumper. Remove any burrs.

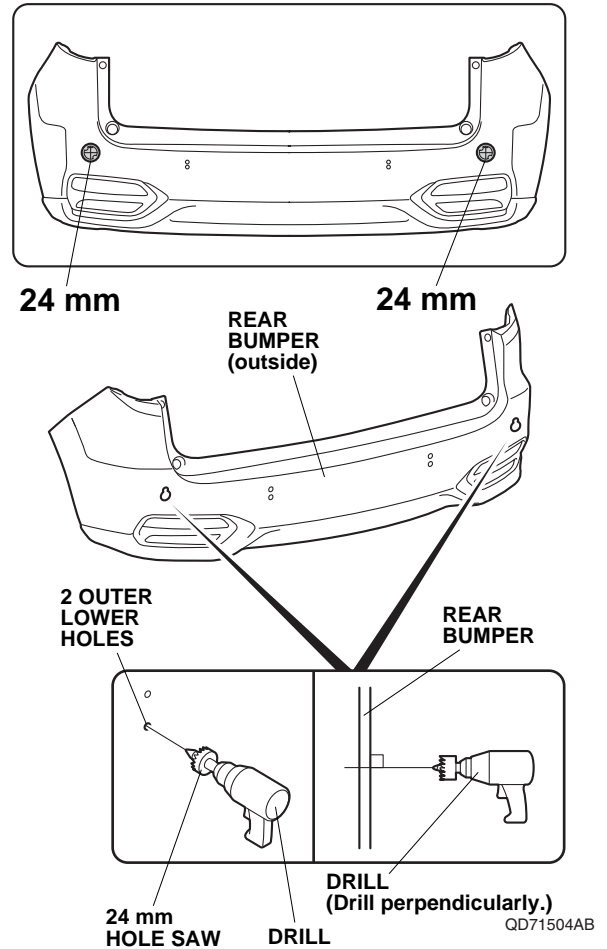

50. While wearing eye protection and drilling from painted side of the rear bumper, enlarge the two lower 3 mm inner holes to 26 mm using a 26 mm hole saw.  
NOTE: Make sure to drill perpendicularly to the rear bumper. Remove any burrs.

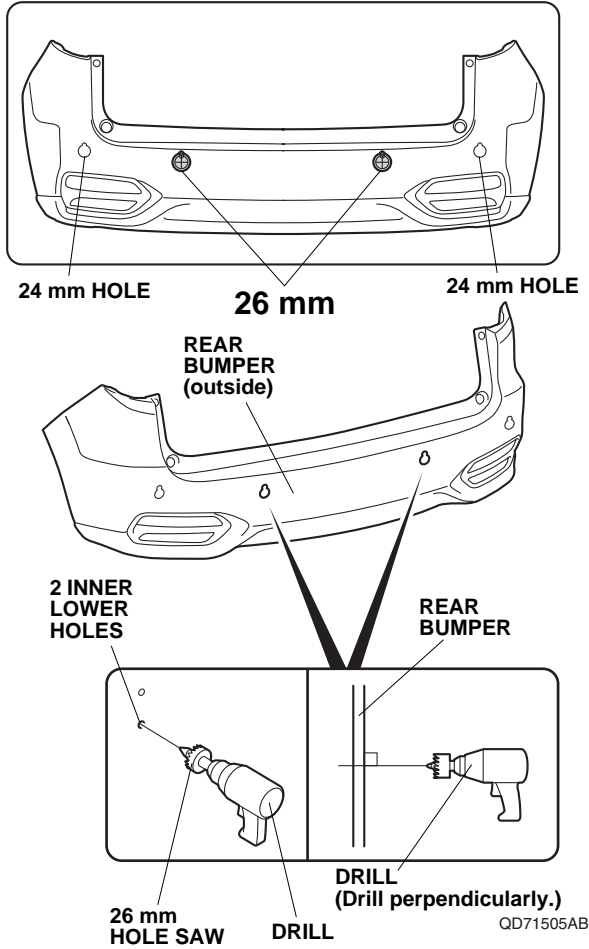

51. Install the left corner sensor (white) and center sensor (blue) to the rear bumper.  
NOTE: The center sensor (blue) have the yellow dot label.

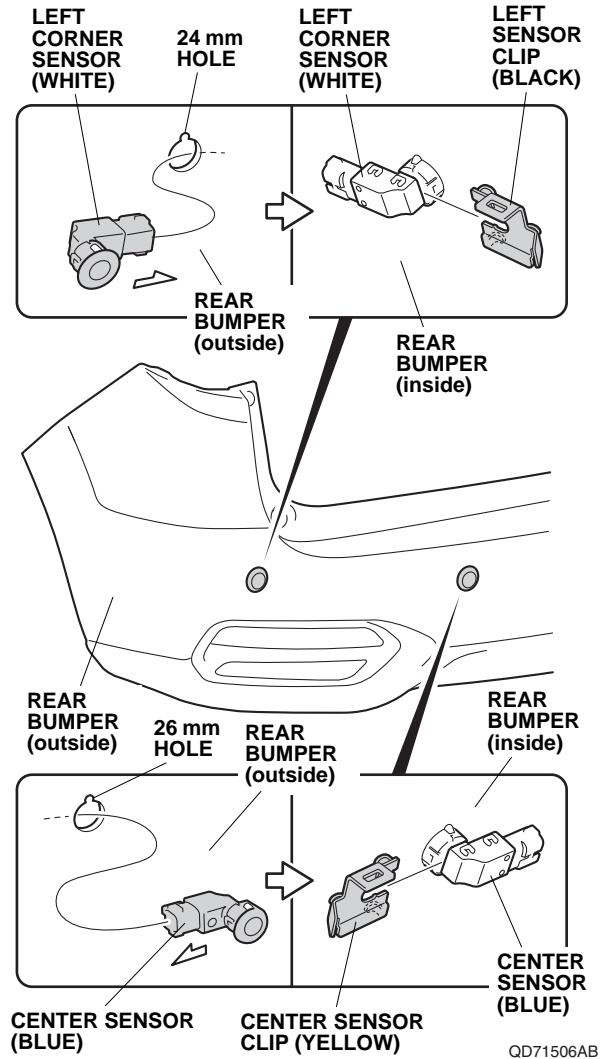

52. Secure the left corner sensor (white) and center sensor (blue) with left sensor clip (black) and center sensor clip (yellow) as shown.

53. Install the right corner sensor (white) and center sensor (blue) to the rear bumper.  
NOTE: The right corner sensor (white) and center sensor (blue) have the yellow dot label.

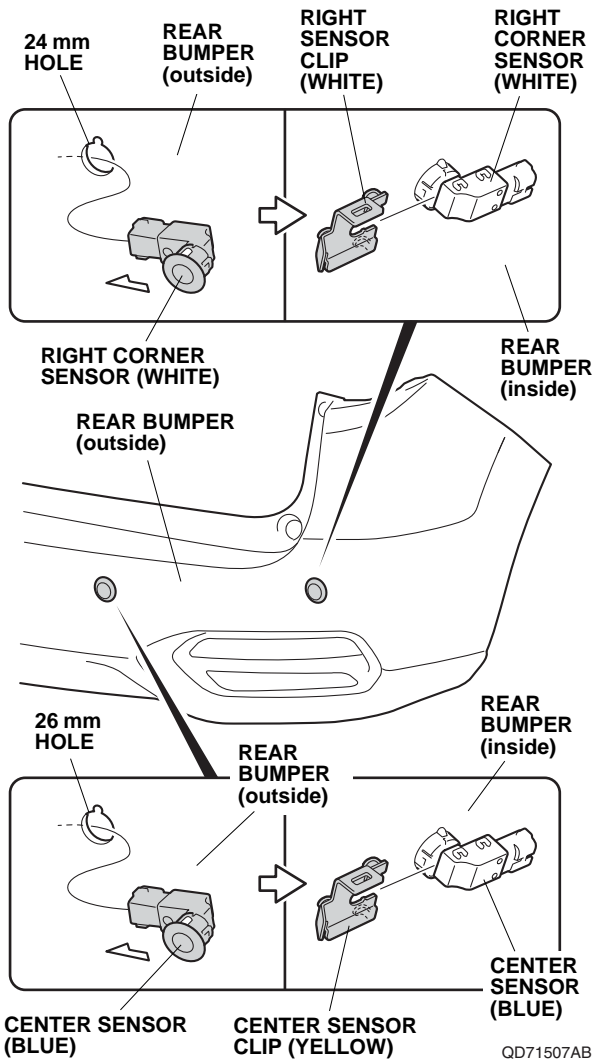

54. Secure the right corner sensor (white) and center sensor (blue) with right sensor clip (white) and center sensor clip (yellow) as shown.

55. Plug the four subharness 2-pin connectors into the two center sensors (blue), right corner sensor (white), and left corner sensor (white).

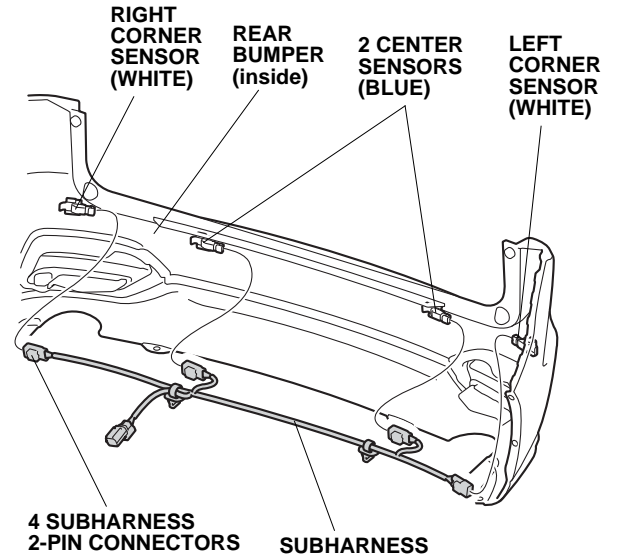

QD71508AB

56. Secure the two subharness clips to the two center sensor clips as shown.

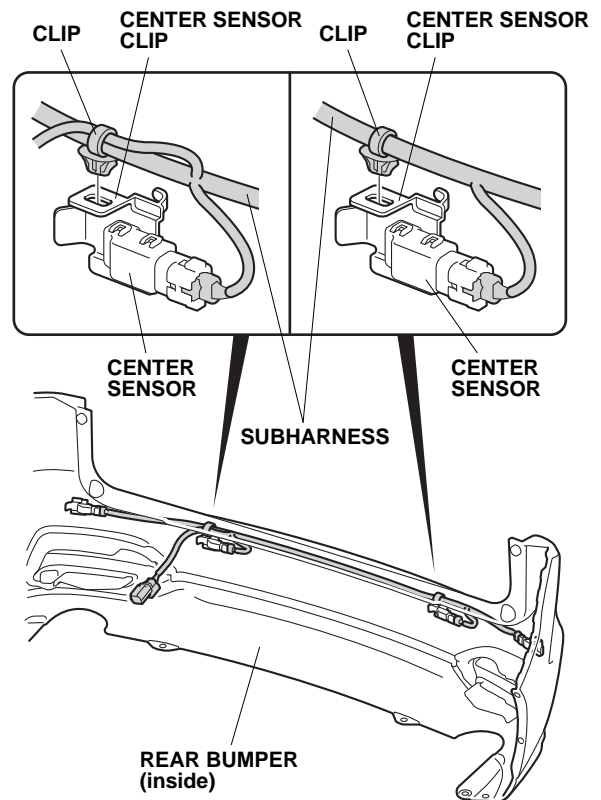

QD71509AB

- Using isopropyl alcohol on a shop towel, thoroughly clean the rear bumper where the aluminum tapes will attach.

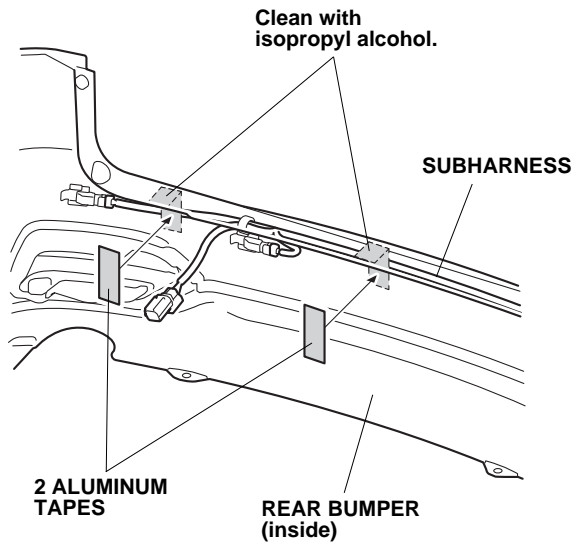

- Secure the subharness to the rear bumper with the two aluminum tapes.
- With the help of an assistant, bring the rear bumper next to the rear of the vehicle, plug the subharness 8-pin connector into the backup sensor harness 8-pin connector, and reinstall the rear bumper.

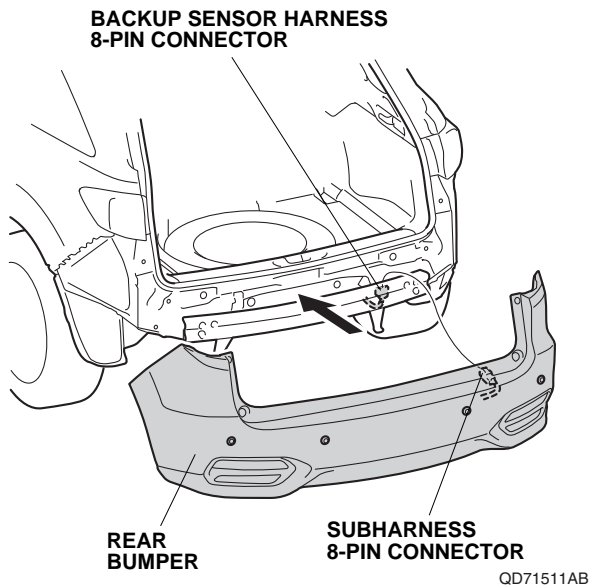

- Check that all wire harnesses are routed properly and that all connectors are plugged in.
- Reinstall all removed parts.
- Reconnect the negative cable to the battery.
- Press and hold the radio power button for two seconds to restore the radio and navi (if equipped) system functions.
- Reset the clock on vehicle without navigation.

### Check the Operation of the Backup Sensors

- Check that the backup sensors work properly as described in the Accessory User's Information Manual supplied with the backup sensor kit.

### Adjust the Volume Control

The factory setting is maximum volume. After confirming the operation, turn the volume control knob to the appropriate level, using a small flat-tip screwdriver. Do not force the adjuster as it could damage the unit.

