



INSTALLATION INSTRUCTIONS

Accessory
ENGINE BLOCK HEATER
P/N 08T44-SNA-102

Application
2018 ILX

Publications No.
VERSION 1
Issue Date
SEP 2017

PARTS LIST

Engine block heater

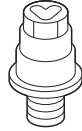

Aluminum washer



Heater harness

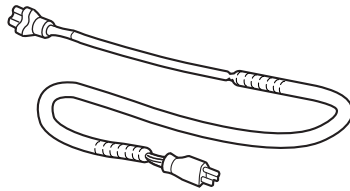

Protective cap

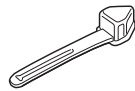

12 Black wire ties
(3 Not used)

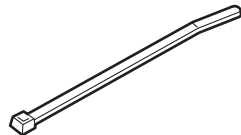

7 Wire ties with clip
(6 Not used)

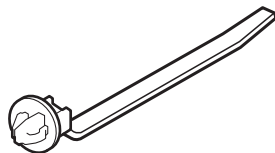

5 Brown wire ties

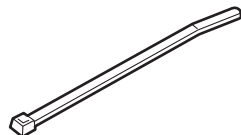

TOOLS AND SUPPLIES REQUIRED

Phillips screwdriver

Ratchet

8 mm, 10 mm, 19 mm, and 24 mm Sockets

Torque wrench

Diagonal cutters

Heavy gloves

Drain pan

Ruler

Tape measure

White marker

Coolant (Acura Long Life Antifreeze/Coolant Type 2)

Eye protection (face shield, safety goggles, etc.)

Blanket

Drill

3 mm and 5 mm Drill bits

Pushpin

Fender cover

Tape

File

Shop towel

Needle nose pliers

The following tool is available through the Acura Tool and Equipment Program. On the iN, click on Service > Service Bay > Tool and Equipment Program, then enter the number under "Search." Or, call 888-424-6857.

Trim Tool Set (T/N SOJATP2014)

Illustration of the Engine Block Heater in the Vehicle

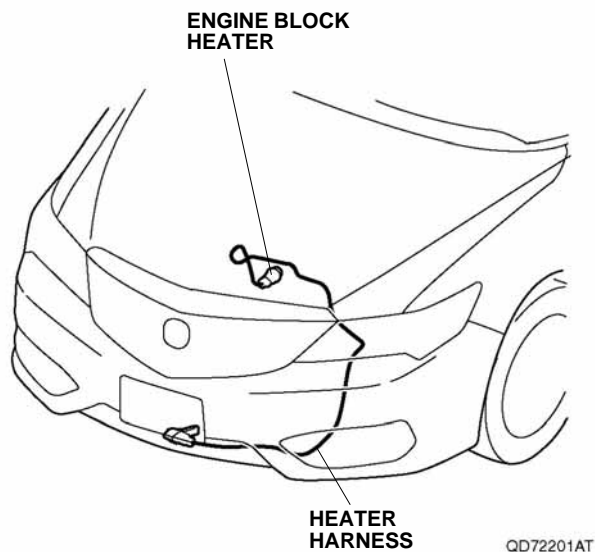

INSTALLATION

Client Information: The information in this installation instruction is intended for use only by skilled technicians who have the proper tools, equipment, and training to correctly and safely add equipment to your vehicle. These procedures should not be attempted by “do-it-yourselfers.”

NOTE:

- Always use Acura Long Life Antifreeze/Coolant Type 2. Using a non-Acura coolant can result in corrosion, causing the cooling system to malfunction or fail.
- To avoid burning out the element, do not operate the engine block heater until it is installed in the vehicle and you have added coolant.

1. Disconnect the negative cable from the battery.
2. Allow the engine and all cooling system components to cool down.

3. Place a clean drain pan under the radiator drain plug, then remove the drain plug from the bottom of the radiator to drain the coolant. Remove the radiator cap to increase the flow.

NOTICE: Radiator coolant will damage the paint. Quickly rinse any spilled coolant from the paint.

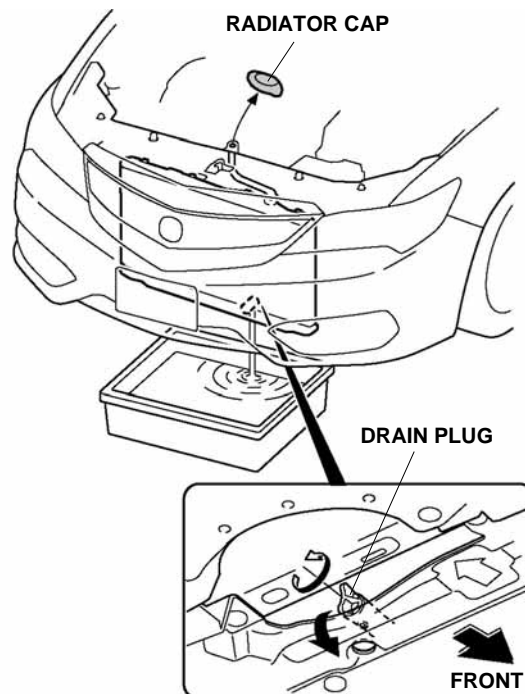

4. Drain the coolant completely, then reinstall the radiator cap.

5. Remove the front bumper:
 - Attach tape to the areas shown on each side.
 - Wrap a shop towel around the hood latch.

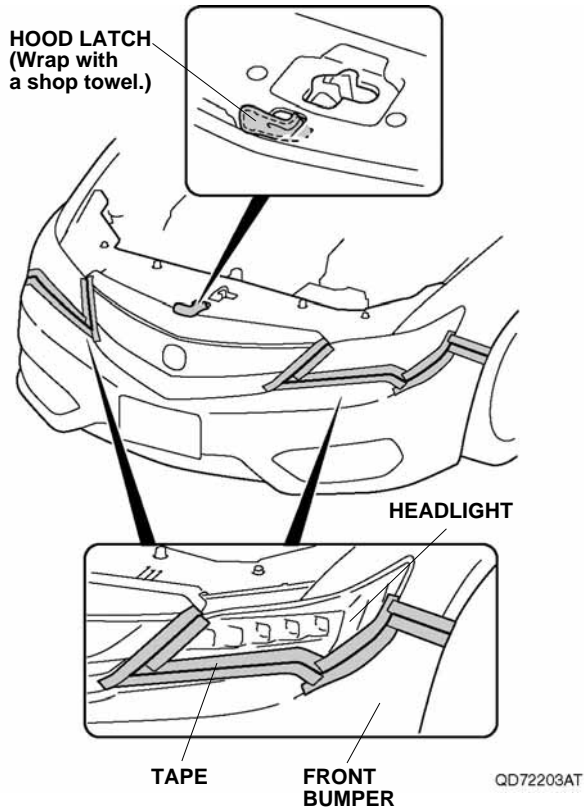

- Remove the front bulkhead cover.

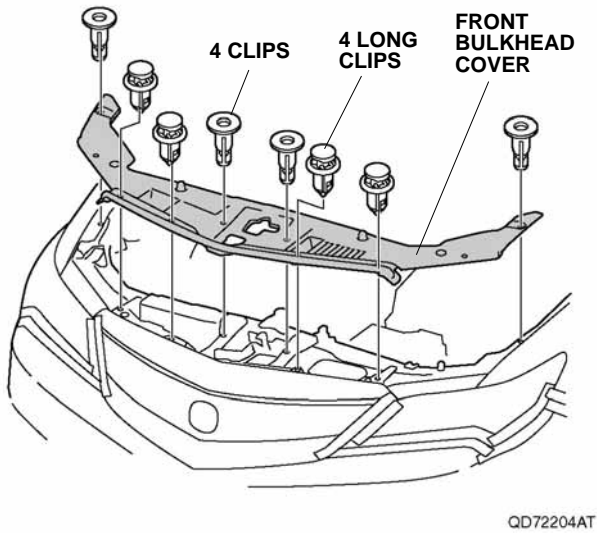

- Remove the three medium clips.

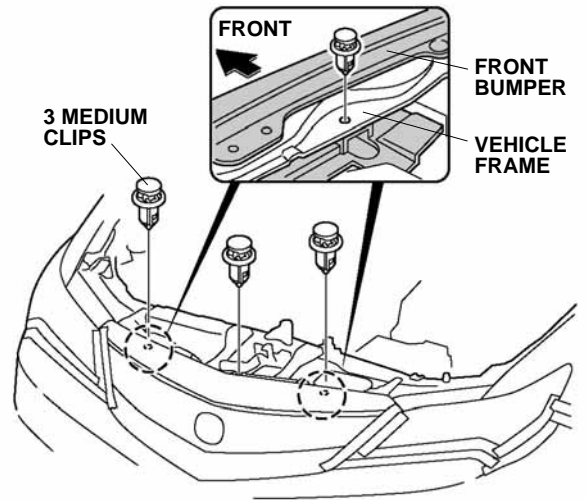

- Remove the two self-tapping screws, two bolts, two short clips, and twelve medium clips.

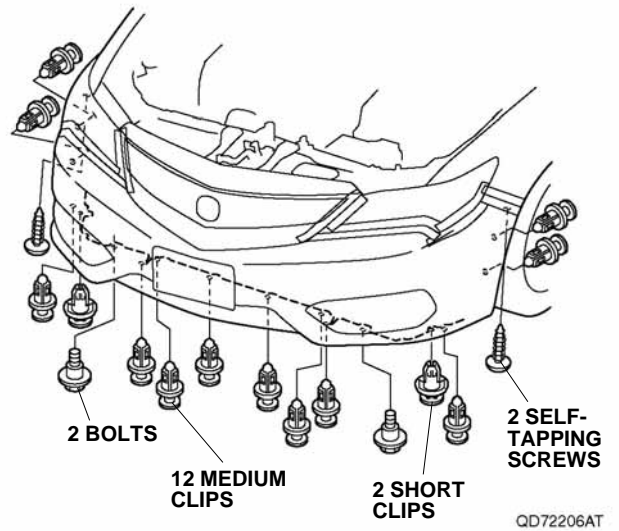

- Release the four retaining tabs on each side.

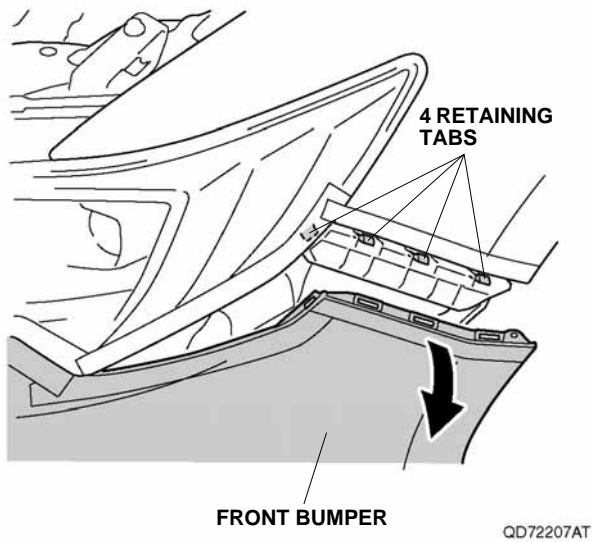

- With the help of an assistant, release the four retaining tabs on each side.

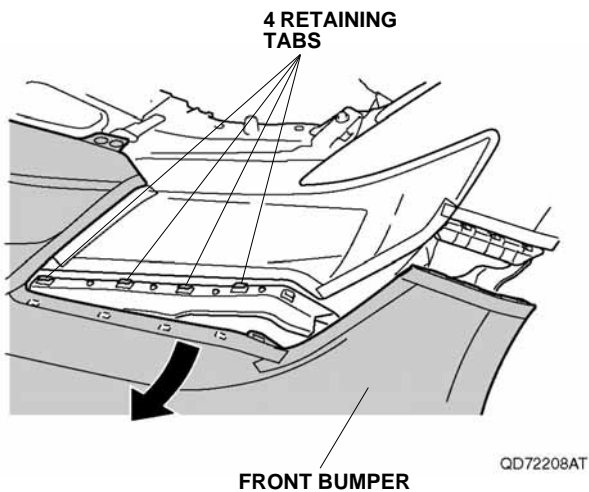

- With the help of an assistant, remove the front bumper and unplug the vehicle connector. Place the front bumper on a blanket to prevent damage.

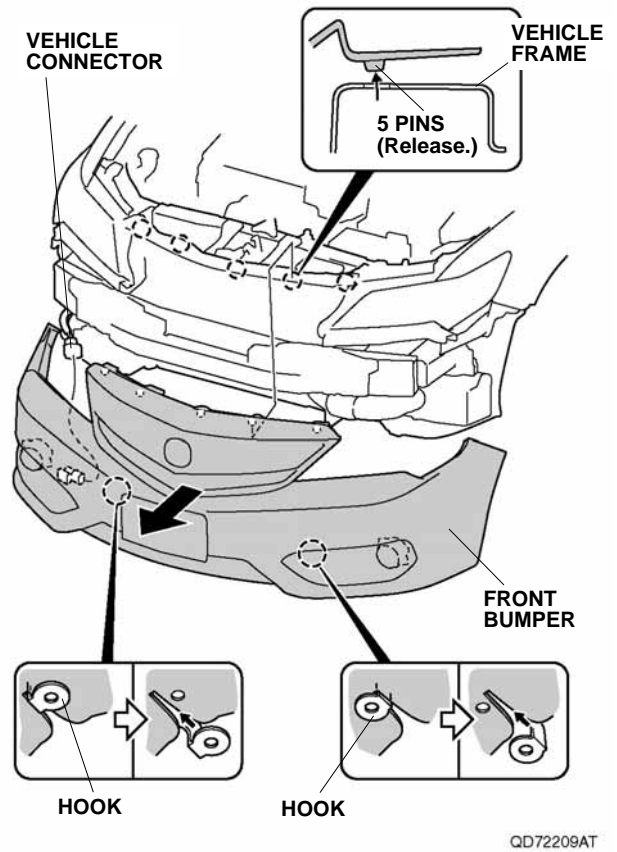

6. Open the positive cable cover and disconnect the positive (+) battery cable from the battery.

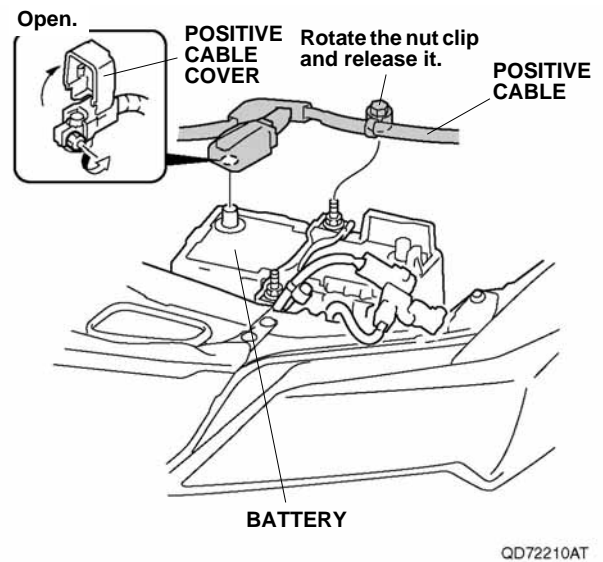

7. Remove the battery, the plate, and the covers.

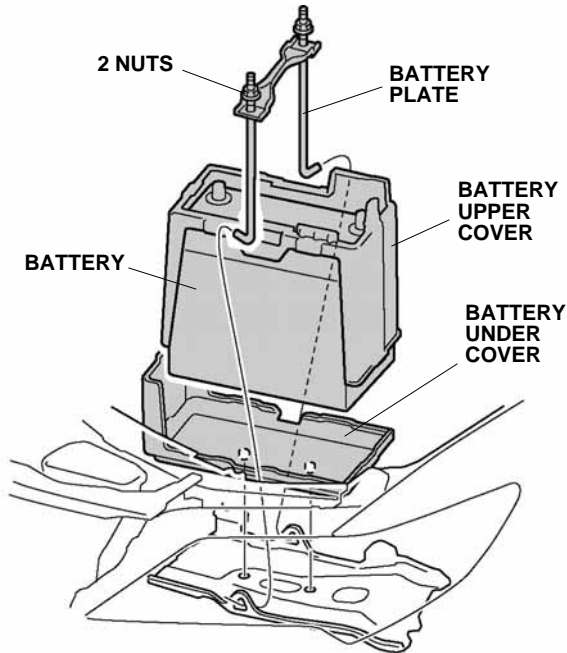

QD72211AT

8. Using a tape measure, measure the heater harness and mark it at the A, B, C, D, E, and F points shown.

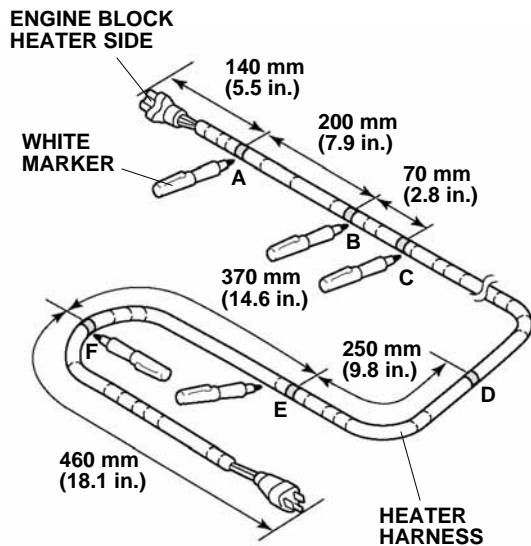

QD72212BT

9. Install one wire tie with clip to the heater harness at point E.

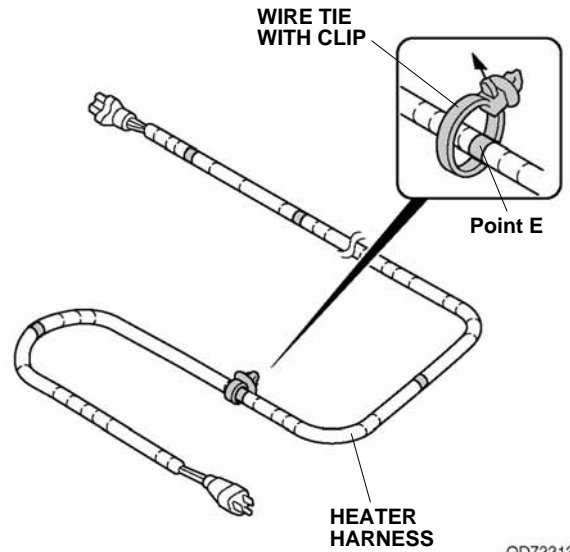

QD72213AT

10. Remove the coolant filler assembly bolts.

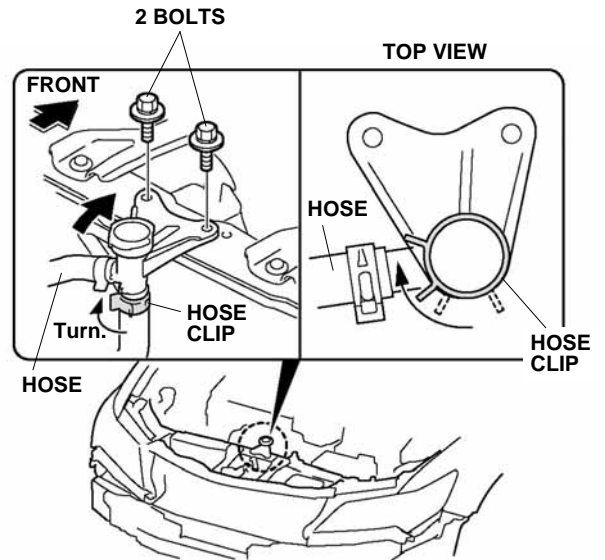

QD72214DT

11. Rotate the coolant hose clip as shown.

12. Locate and remove the drain bolt and washer. Be careful as left over coolant in the engine jackets may flow out. Save the drain bolt for when the engine block heater is uninstalled.
NOTE: Use a new washer when the drain bolt is reinstalled.

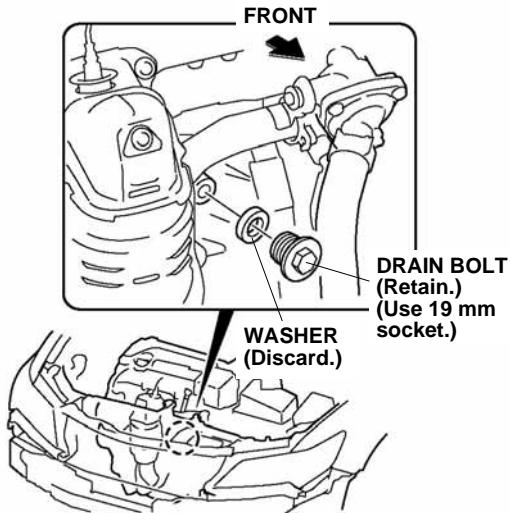

QD72215AT

13. Install the engine block heater with the aluminum washer into the bolt hole using a 24 mm socket and a torque wrench. Torque the engine block heater to 85 N·m (63 lb-ft).

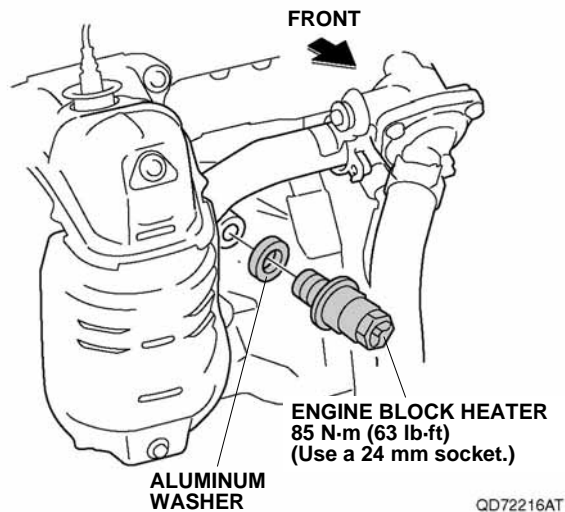

QD72216AT

14. Plug the connector end of the heater harness into the engine block heater. Make sure the heater harness connector is fully seated in the engine block heater.

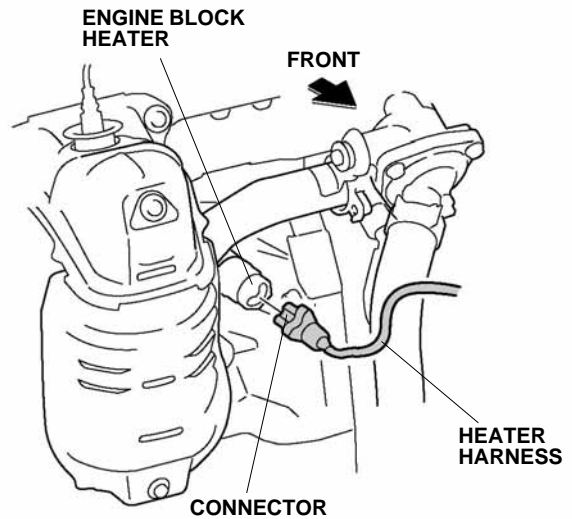

QD72217AT

15. Secure the heater harness to the thermostat case with one brown wire tie at the white mark (point A).

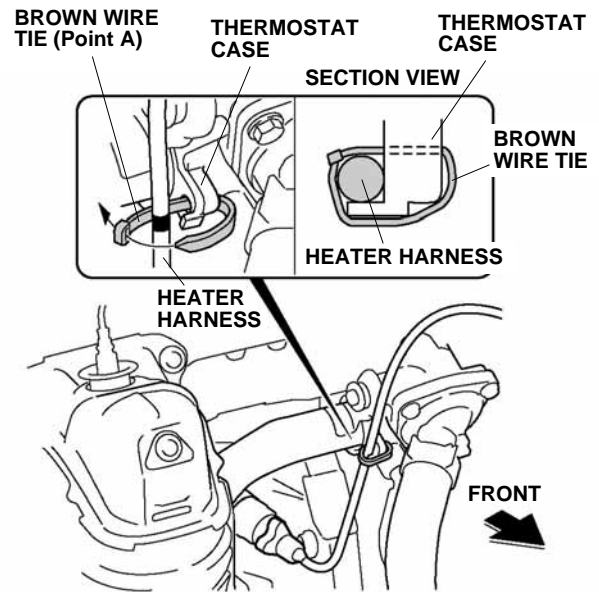

QD72218AT

16. Reinstall the coolant filler assembly that was removed in step 10.

- Route the heater harness as shown. Secure the heater harness to the coolant filler assembly with the two brown wire ties at the white mark (point B).

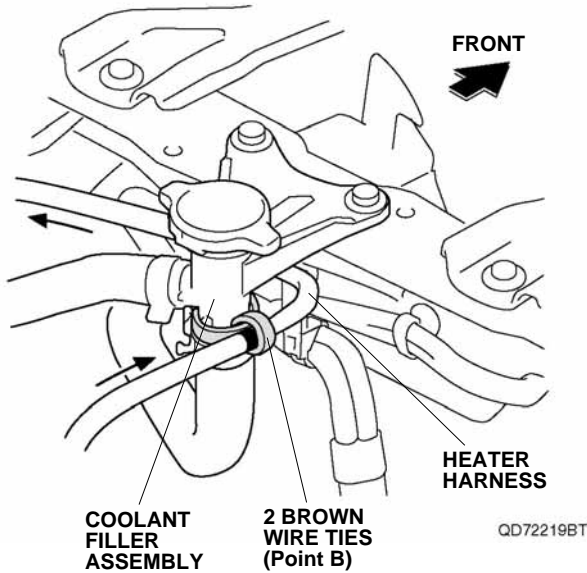

- Line up the heater harness white mark (point C) with the vehicle clip, secure the heater harness to the vehicle harness with a brown wire tie.

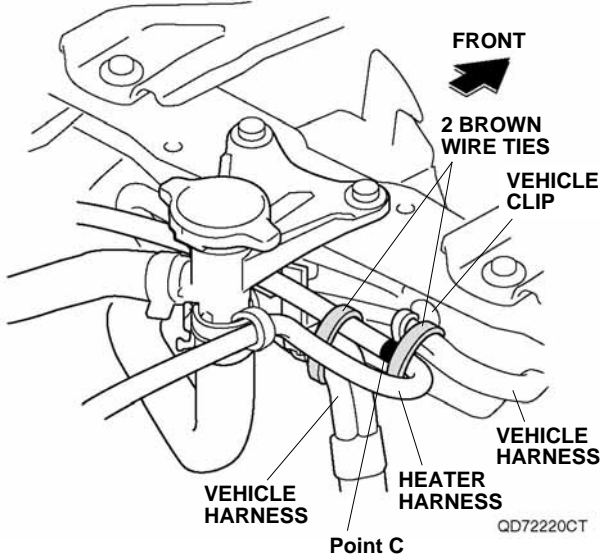

- Secure the heater harness to the vehicle harness with one brown wire tie.

- Route the corrugated tube end of the heater harness as shown and secure it to the coolant reserve tank stay with one black wire tie.

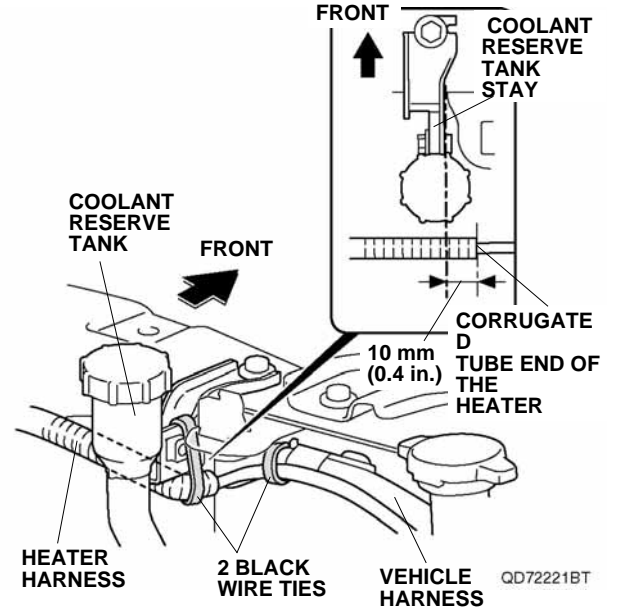

- Secure the heater harness to the vehicle harness with one black wire tie.
- Secure the heater harness to the vehicle harness with two black wire ties.

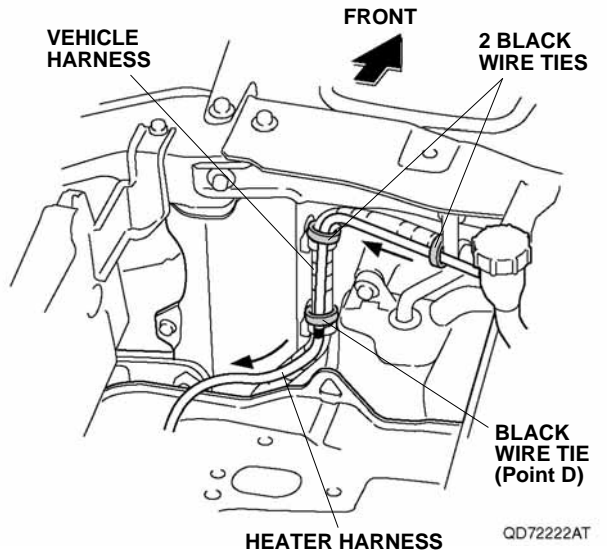

- Secure the heater harness to the vehicle harness with a black wire tie at the white mark (point D).

24. Route the heater harness under the headlight as shown.

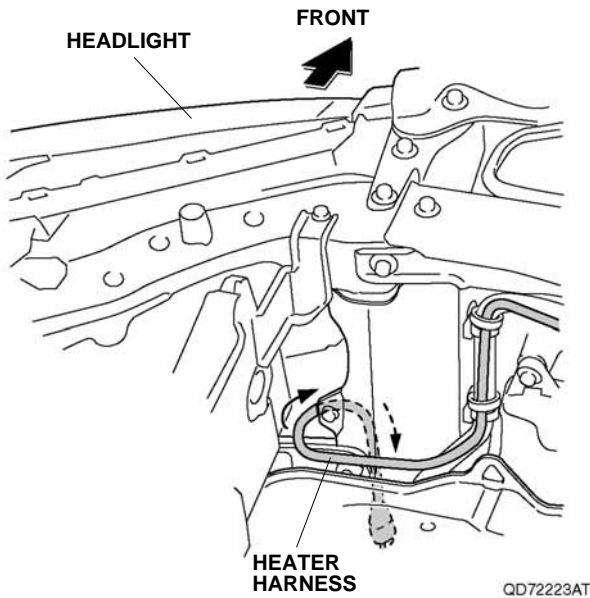

25. Secure the clip (point E) on the heater harness to the vehicle panel.

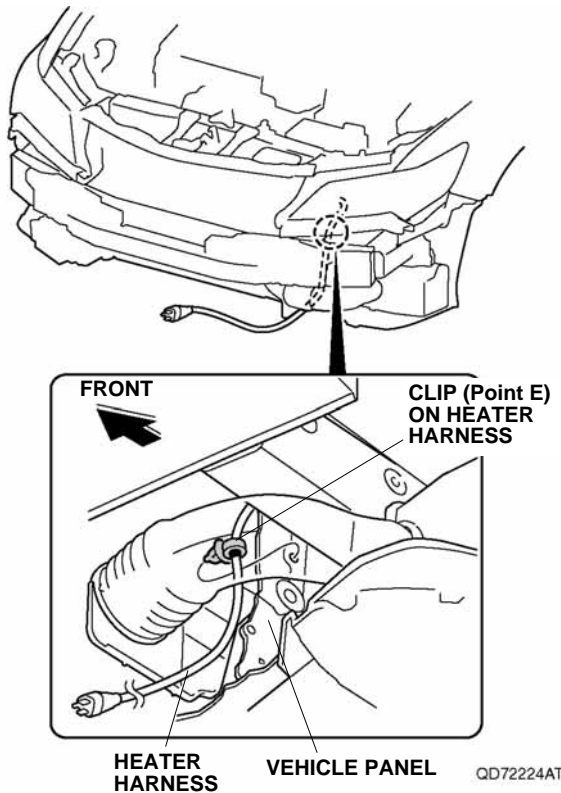

26. Secure the heater harness to the vehicle panel with a black wire tie.

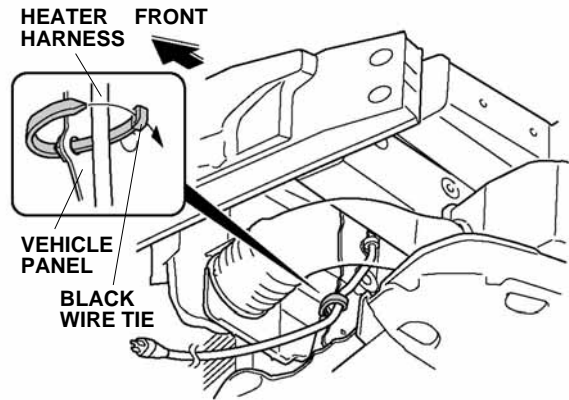

27. Using a pushpin, pierce the center of the two scribe marks on the duct.

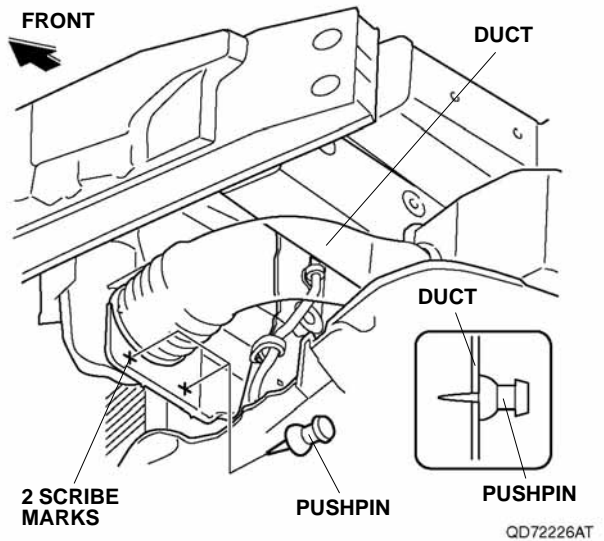

28. While wearing eye protection, drill the two pierced marks with a 3 mm drill bit, then enlarge the holes with a 5 mm drill bit. Remove any burrs.

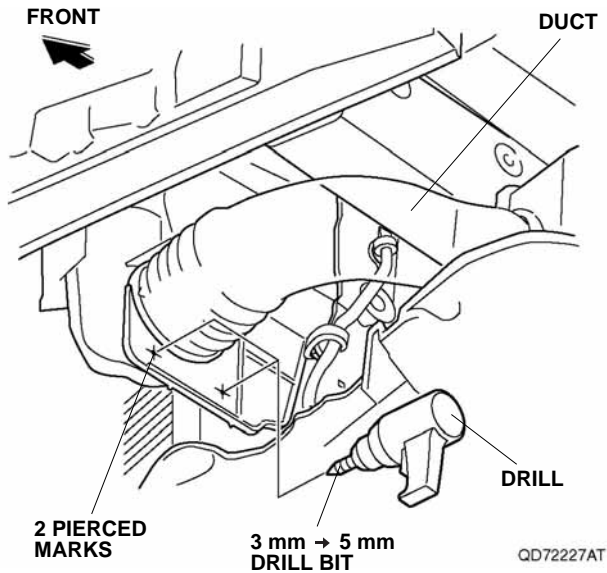

29. Secure the heater harness to the duct with one black wire tie.

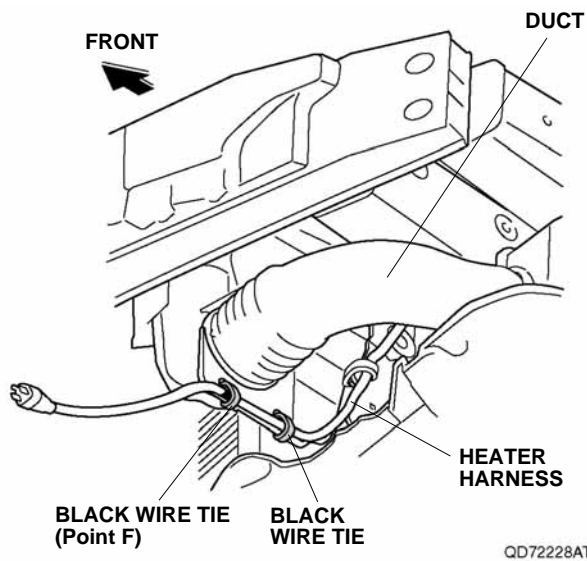

30. Secure the heater harness to the duct with one black wire tie at the white mark (point F).

31. With the help of an assistant, bring the front bumper close to the vehicle. Route the heater harness through the front bumper as shown, then reinstall the front bumper.

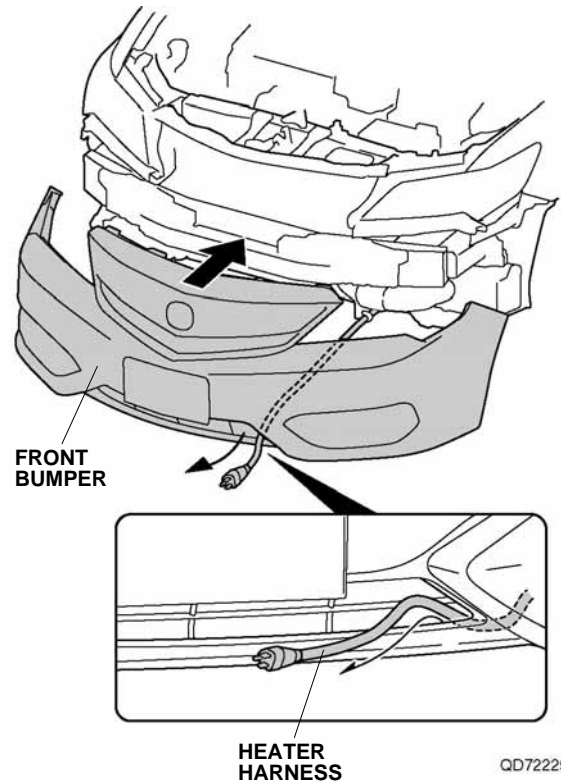

32. Attach the protective cap to the front bumper, and plug the heater harness connector into the protective cap.

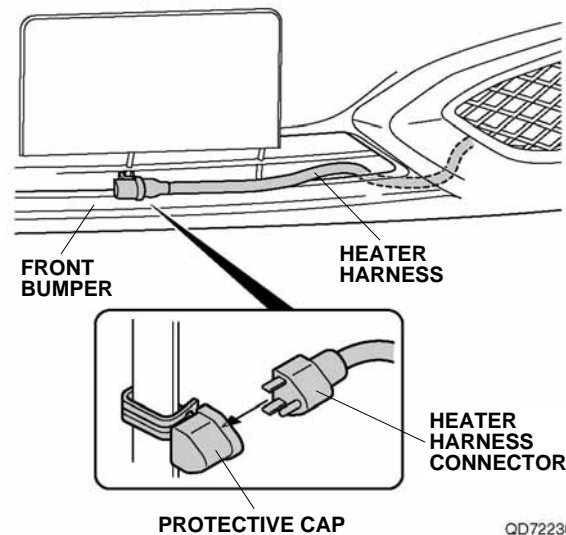

33. Secure the heater harness to the front bumper with a black wire tie.

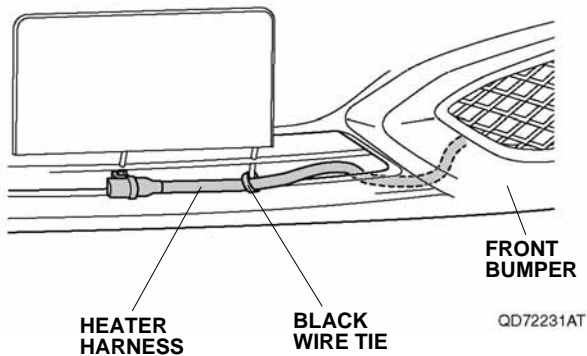

34. Reinstall all removed parts.
35. Reinstall the radiator drain plug.
36. Remove the radiator cap and fill the system with the recommended coolant. Follow the instructions in the Service Manual to fill the cooling system. Check that there are no leaks, especially the area around the engine block heater.
37. Make sure that the heater harness is routed properly and all connectors are plugged in.
38. Reinstall the radiator cap.
39. Keep the drain bolt (removed in step 12) in a safe place.
40. Reconnect the negative cable to the battery.
41. Press and hold the radio power button for two seconds to restore radio and navi (if equipped) system functions.
42. Reset the clock.