



# INSTALLATION INSTRUCTIONS

Accessory  
**BACKUP SENSORS**

Application  
**2018 ILX**

Publications No.  
**VERSION 1**  
Issue Date  
**SEP 2017**

## PARTS LIST

### Backup Sensors Attachment Kit P/N 08V67-TX6-200B

Control unit

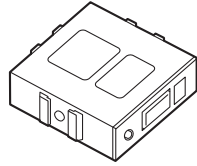

Control unit bracket

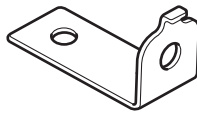

Buzzer

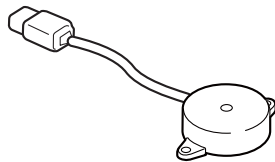

Backup sensor harness

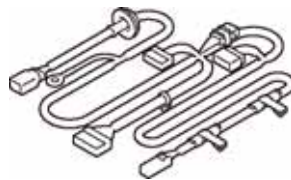

Subharness

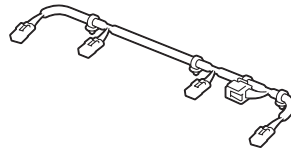

2 Corner sensor clips  
(Identification mark: 5°L)

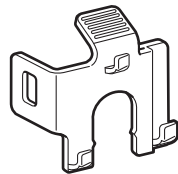

2 Center sensor clips  
(Identification mark: 9°L)

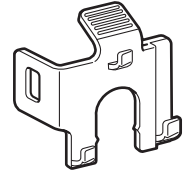

8 Wire ties  
(Some may not be used)

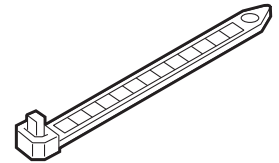

3 Aluminum tapes

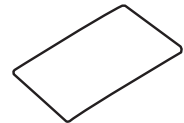

Fuse label



Flange bolt

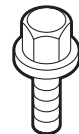

3 Urethane tapes

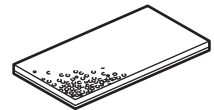

3 Wire ties with clip

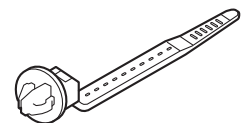

Accessory User's Information Manual

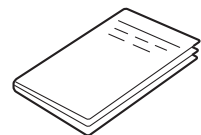

**Backup Sensors Kit  
P/N 08V67-TX6-200K**

2 Center sensors

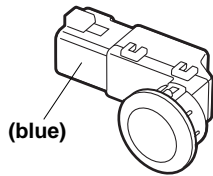

2 Corner sensors

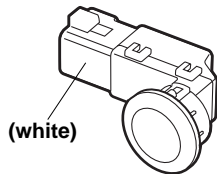

**TOOLS AND SUPPLIES REQUIRED**

- Phillips screwdriver
- Small flat-tip screwdriver
- 10 mm Open end wrench
- 10 mm Socket
- Pushpin
- Ratchet
- 3 mm Drill bit
- Eye protection (face shield, safety goggles, etc.)
- File
- Scissors
- Ruler
- Blanket
- Isopropyl alcohol
- Shop towel
- 24 mm and 26 mm Hole saws
- Drill
- Diagonal cutters
- Electrical tape
- Steel wire
- Tape

*The following tool is available through the Acura Tool and Equipment Program. On the iN, click on Service > Service Bay > Tool and Equipment Program, then enter the number under "Search." Or, call 888-424-6857.*

Trim Tool Set (T/N SOJATP2014)

**Illustration of the Backup Sensors on the Vehicle**

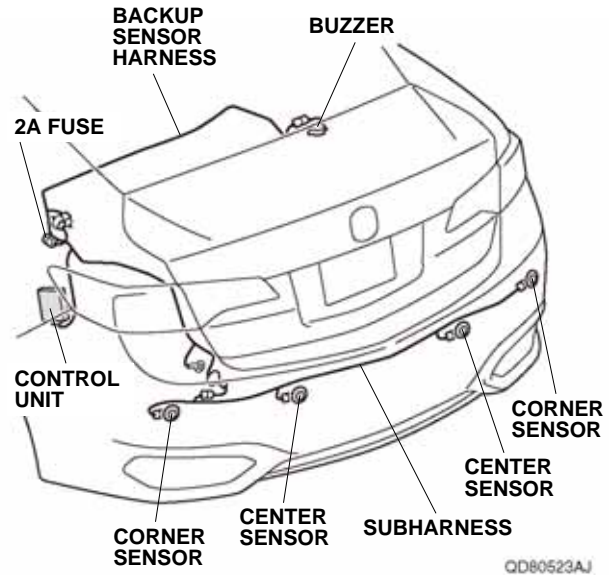

**INSTALLATION**

**Client Information:** The information in this installation instruction is intended for use only by skilled technicians who have the proper tools, equipment, and training to correctly and safely add equipment to your vehicle. These procedures should not be attempted by "do-it-yourselfers."

**NOTE:** Refer to the 2017 ILX Parts Information Bulletin (PIB) for the proper sensor colors.

1. Disconnect the negative cable from the battery.

2. Open the trunk lid. Remove the trunk floor mat.

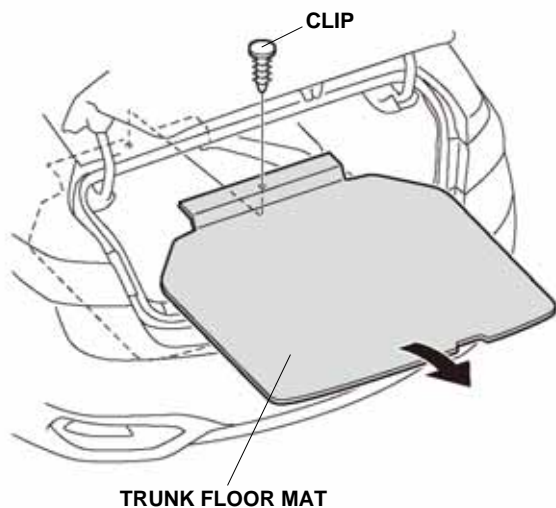

QD80401AJ

3. Remove the tool box.

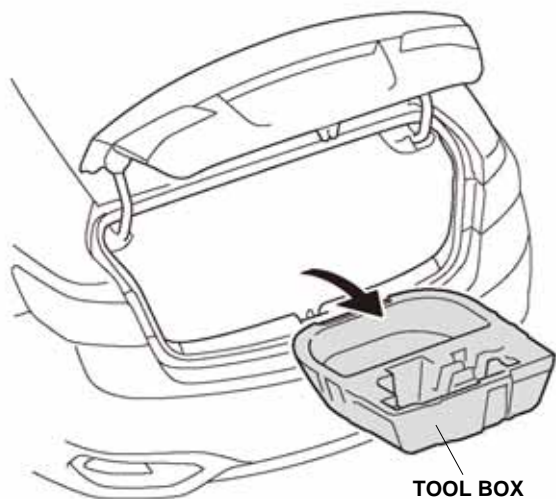

QD80402AJ

4. Remove the trunk rear trim panel.

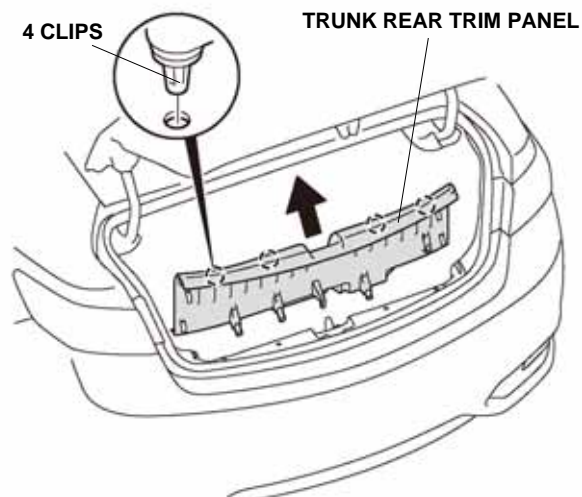

QD80403AJ

5. Pull away the weatherstrip. Peel the left trunk side trim panel.

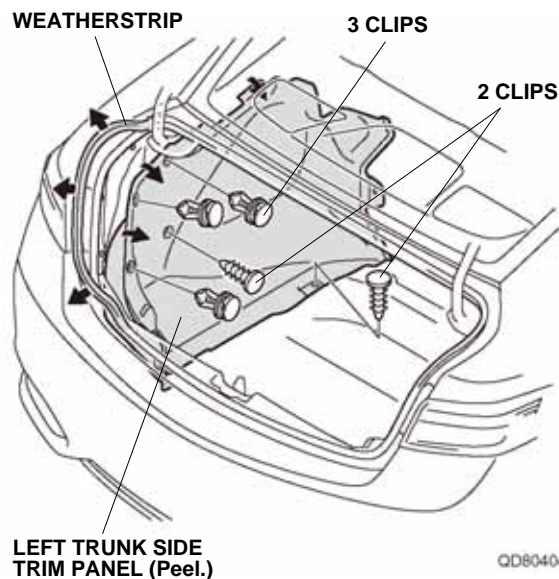

QD80404AJ

6. Remove the lower insulator.

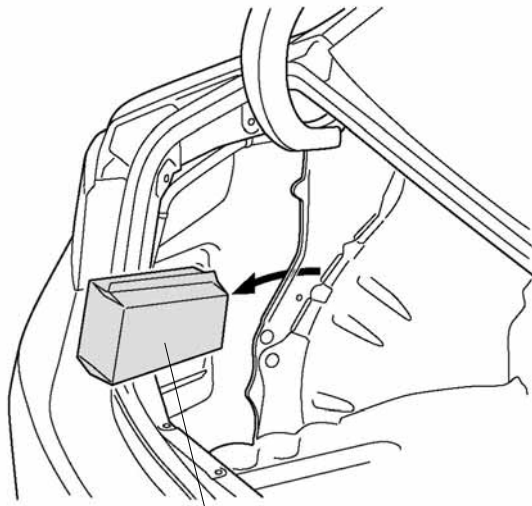

LOWER INSULATOR

QD80405BJ

7. Remove the rear bumper:

- Attach tape to the areas shown on each side.

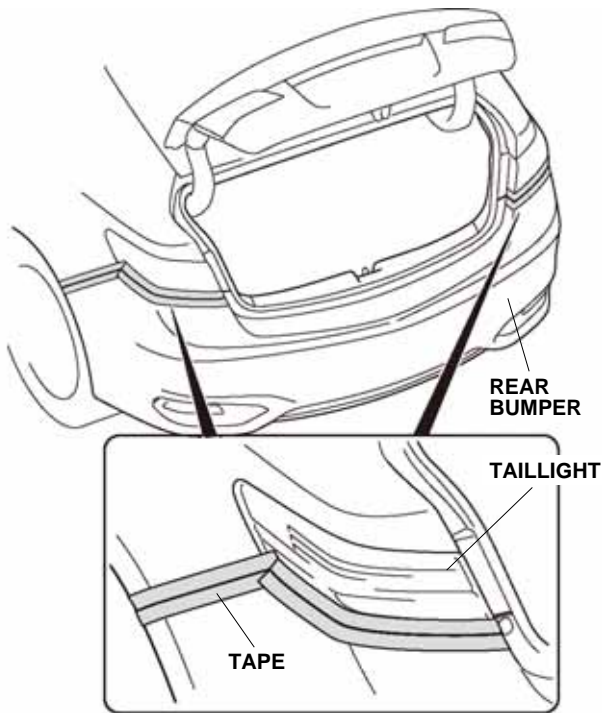

QD80406AJ

- Remove the two bolt covers, the two bolts, and the five clips.

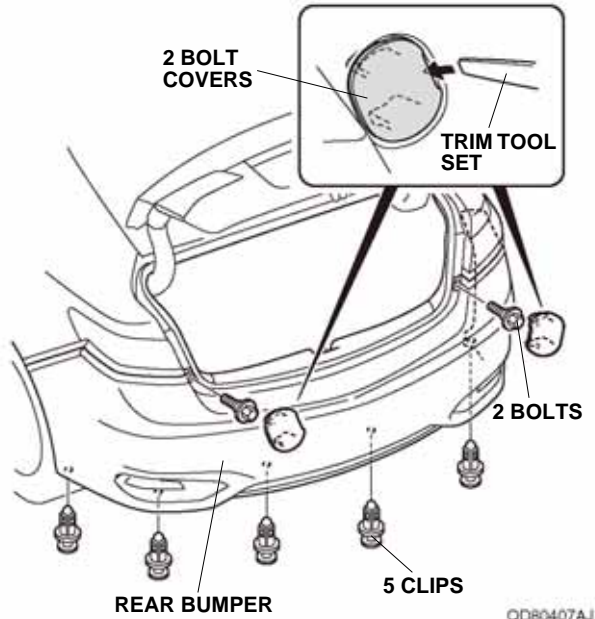

QD80407AJ

- Remove the one self-tapping screw from each side.

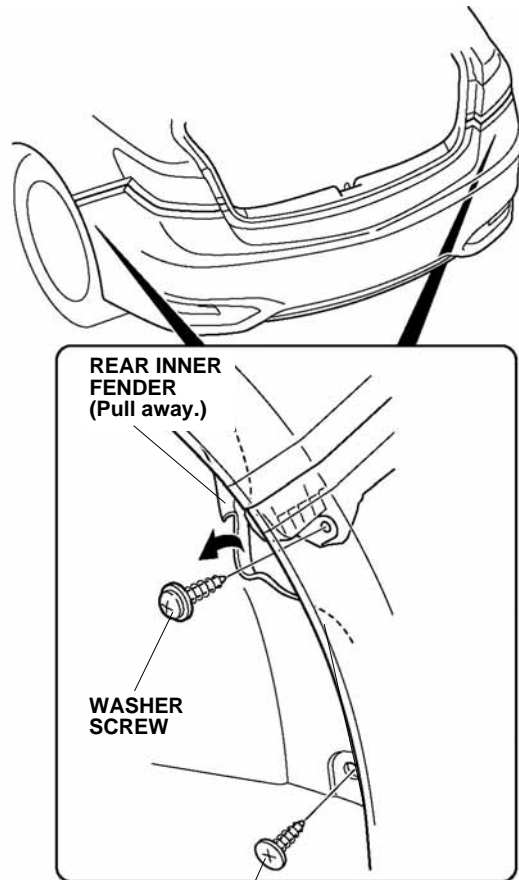

QD80408BJ

- Release the seven retaining tabs on each side.

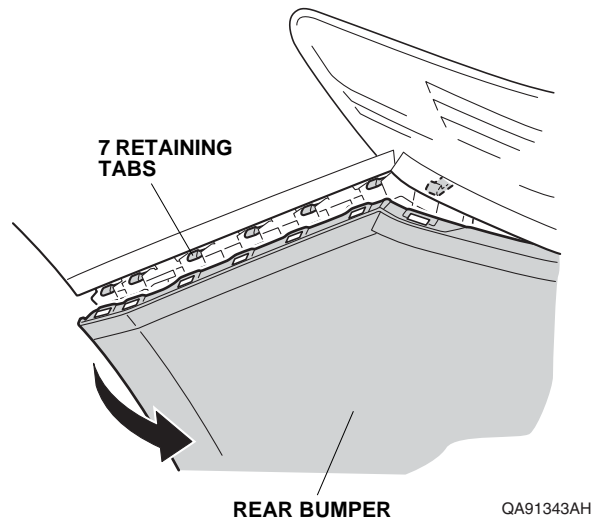

- Release the two retaining tabs on each side.

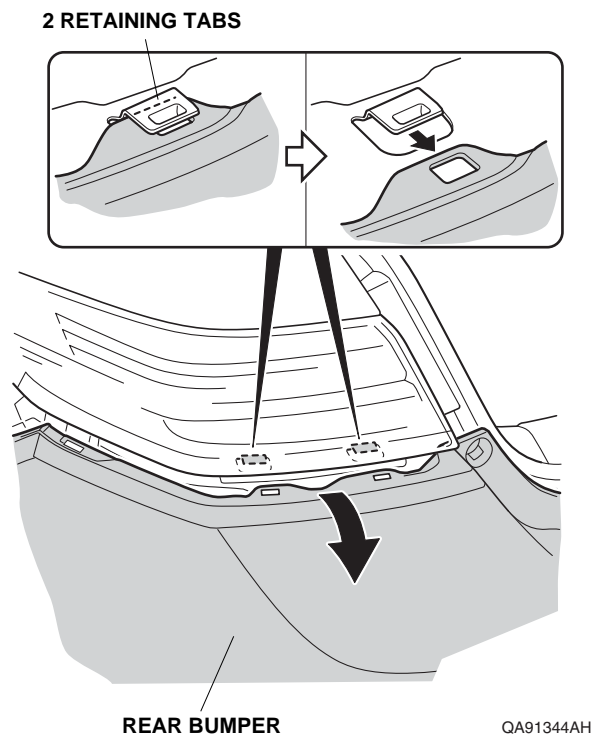

- With the help of an assistant, remove the rear bumper and place it on a blanket to prevent damage.

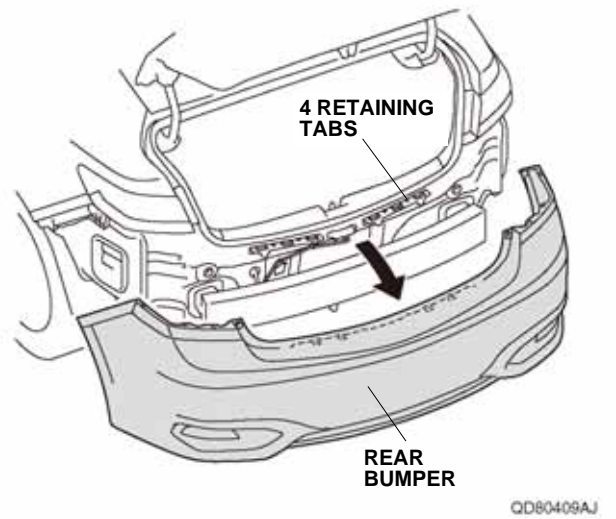

### Routing the Backup Sensor Harness

8. Wrap one urethane tape around the buzzer harness as shown.

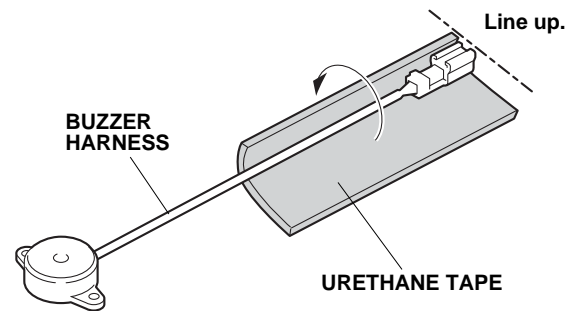

QA00403BJ

- Using isopropyl alcohol on a shop towel, thoroughly clean the vehicle panel where the buzzer will attach.

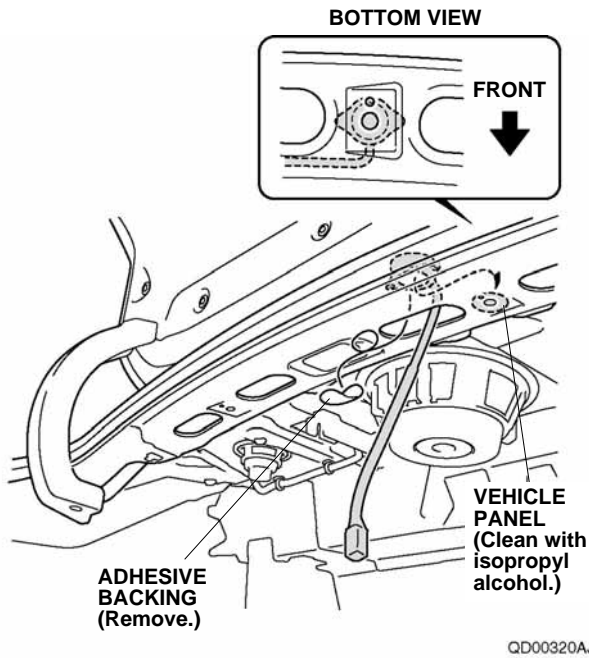

- Remove the adhesive backing from the buzzer and attach it to the vehicle panel.
- Using isopropyl alcohol on a shop towel, clean the fuse case where the fuse label will attach.

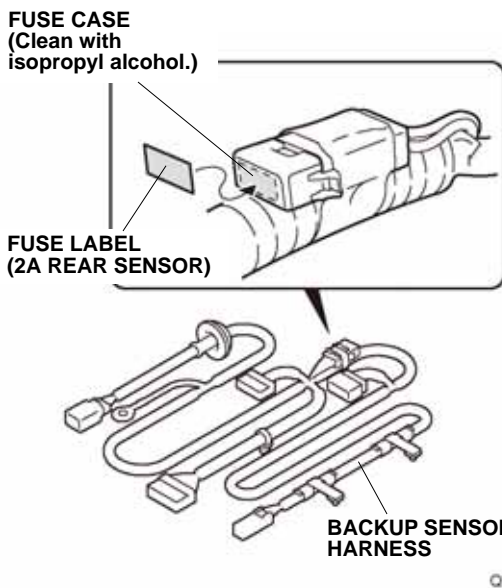

- Attach the fuse label to the backup sensor harness fuse case.

- Route the backup sensor harness as shown.

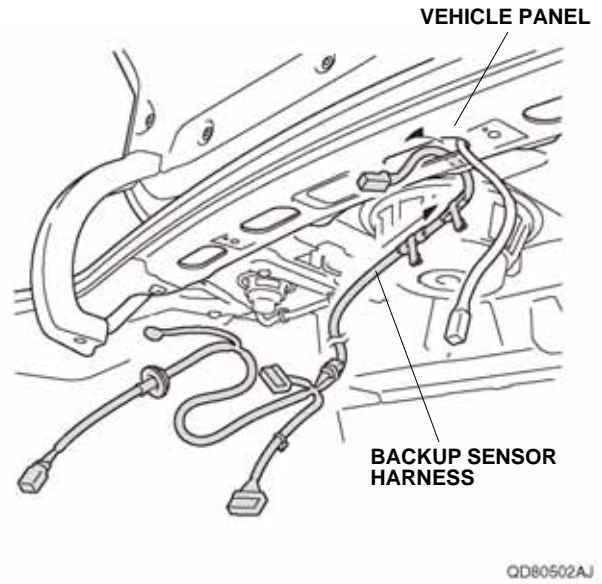

- Plug the backup sensor harness 2-pin connector into the buzzer 2-pin connector.

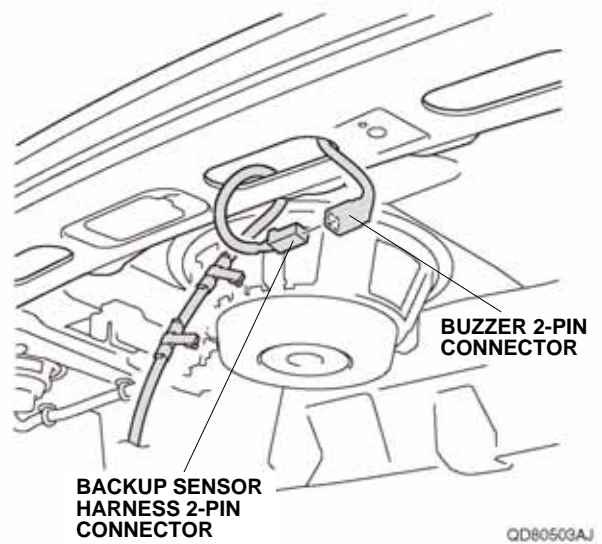

15. Secure the two backup sensor harness clips to the vehicle panel.

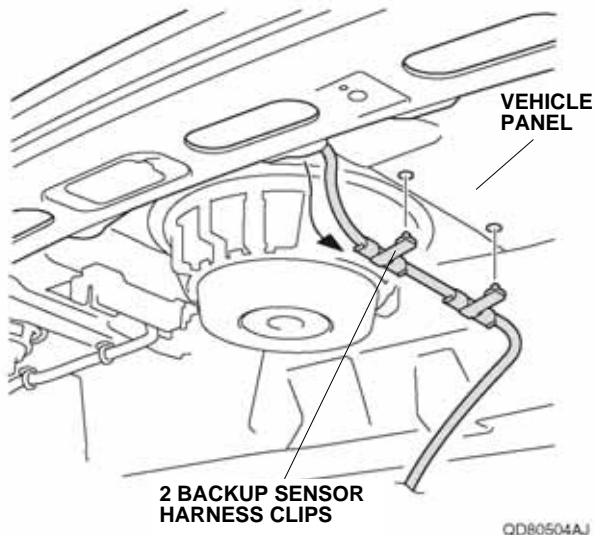

16. Using scissors, cut the urethane tape as shown. Using isopropyl alcohol on a shop towel, clean the vehicle panel where the urethane tape will attach.

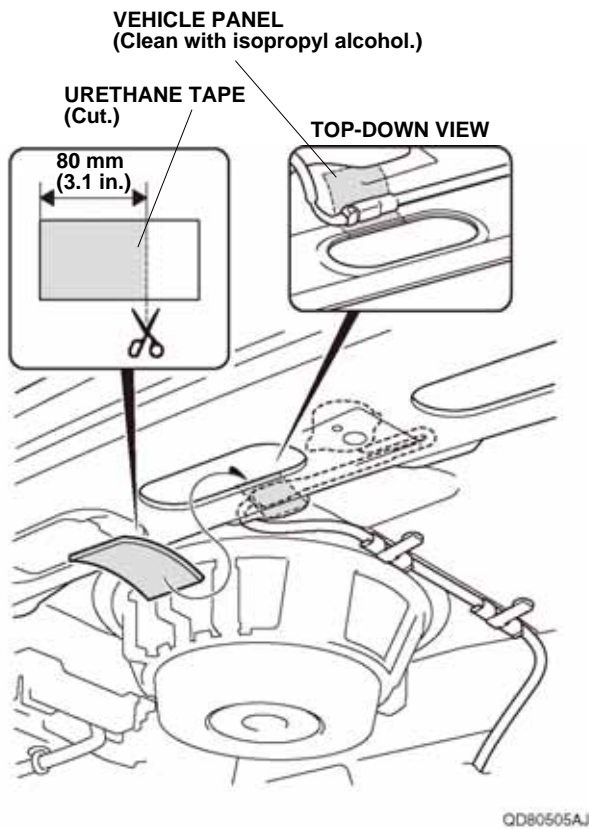

17. Attach the buzzer 2-pin connector to the vehicle panel with the cut urethane tape.

18. **With subwoofer models:** Secure the backup sensor harness to the vehicle harness with a wire tie.

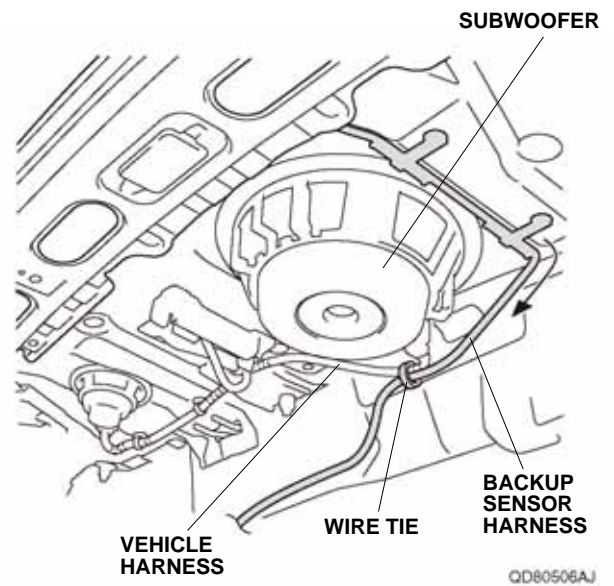

19. Secure the backup sensor harness to the vehicle panel hole with a wire tie with clip.

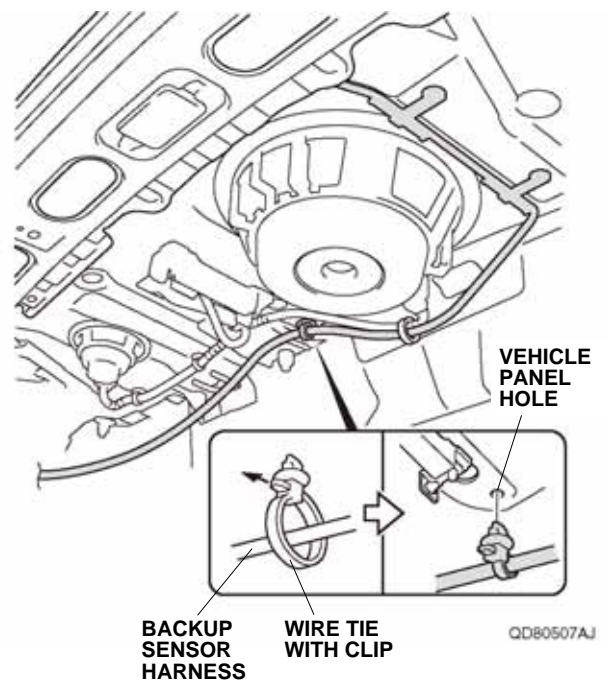

20. Secure the backup sensor harness with the two wire ties with clip as shown. If there is a vehicle harness, cut off the clips of the two wire ties with clip and secure the backup harness to the vehicle harness.

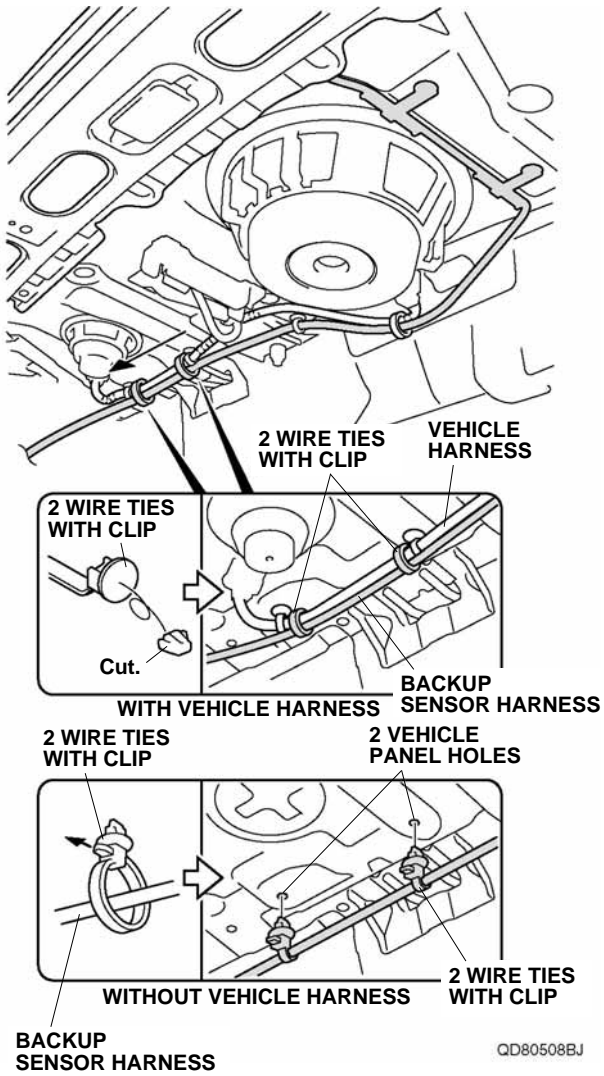

21. Secure the backup sensor harness to the vehicle harness with a wire tie.

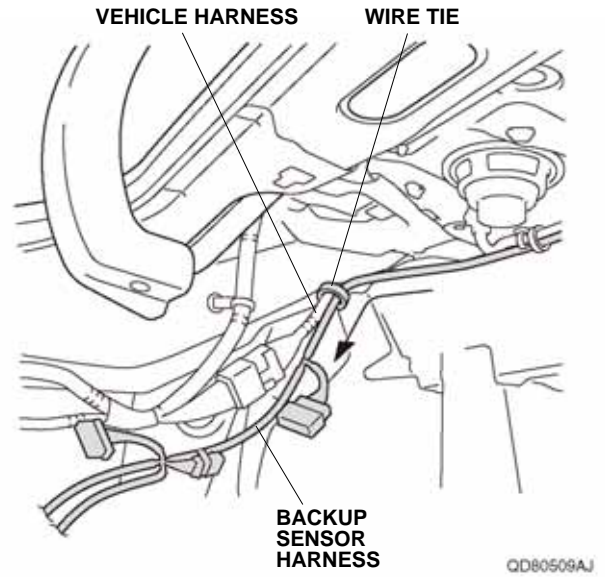



- Unplug the vehicle 28-pin connector, and plug it into the backup sensor harness 28-pin connector. Plug the remaining backup sensor harness 28-pin connector into the vehicle 28-pin connector.

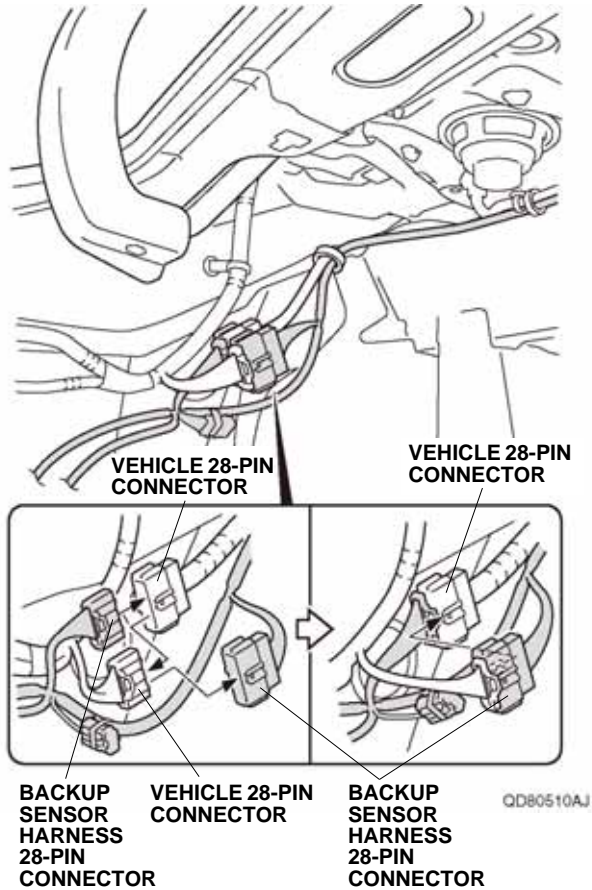

- Slide the backup sensor harness 28-pin connector onto the vehicle 28-pin connector.

- Using isopropyl alcohol on a shop towel, clean the control unit where the urethane tape will attach.

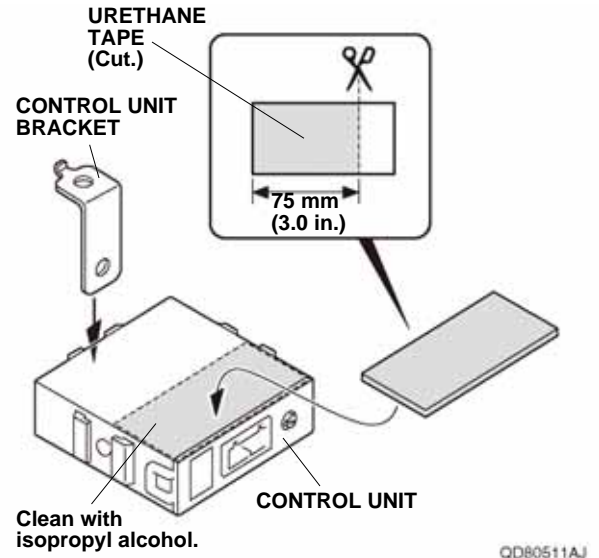

- Using scissors, cut the urethane tape as shown. Attach the cut urethane tape to the control unit.
- Install the control unit bracket to the control unit.
- Secure the control unit to the vehicle panel with the flange bolt.

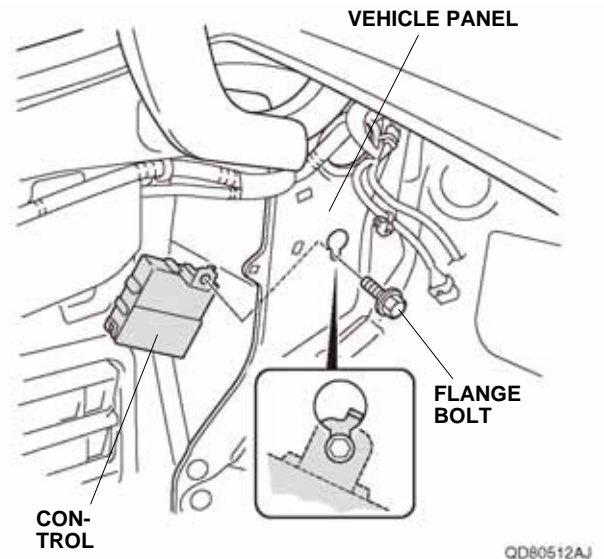

28. Route the backup sensor harness as shown. Plug the backup sensor harness 14-pin connector into the control unit.

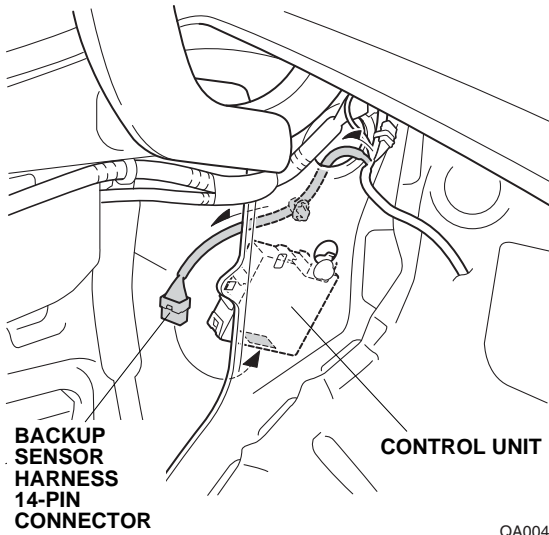

29. Secure the backup sensor harness clip to the vehicle panel hole.

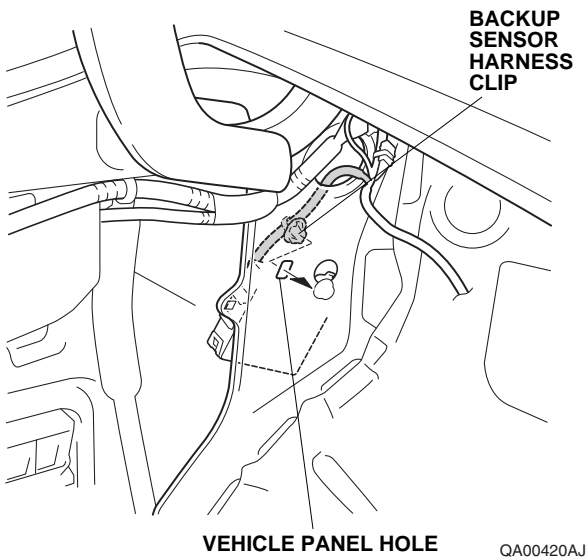

30. Secure the backup sensor harness to the vehicle harness with three wire ties.

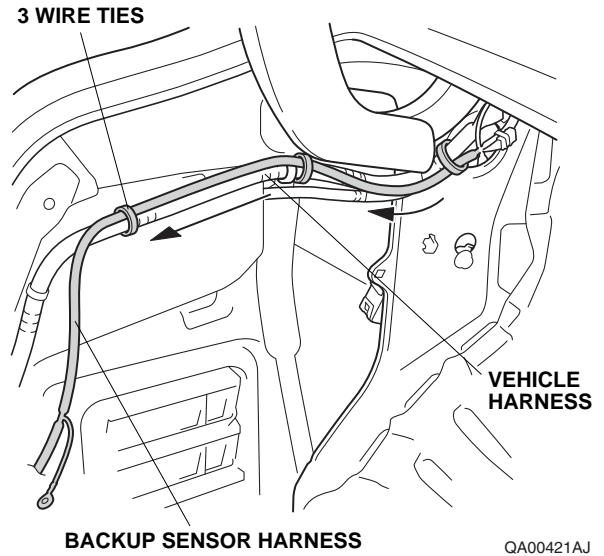

31. Secure the backup sensor harness to the vehicle harness with three wire ties.

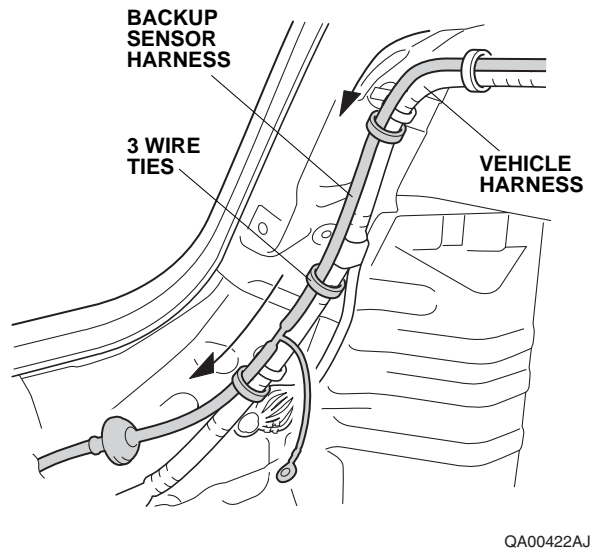

32. Remove the vehicle ground bolt. Attach the backup sensor harness ground terminal to the vehicle ground terminal, and reinstall the vehicle ground bolt.
- NOTICE:** Do not put the ground terminal calkings on top of one another.

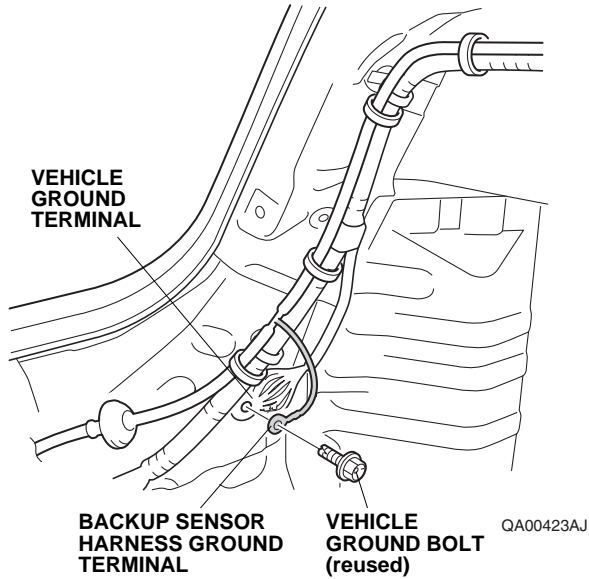

33. Remove the vehicle grommet.

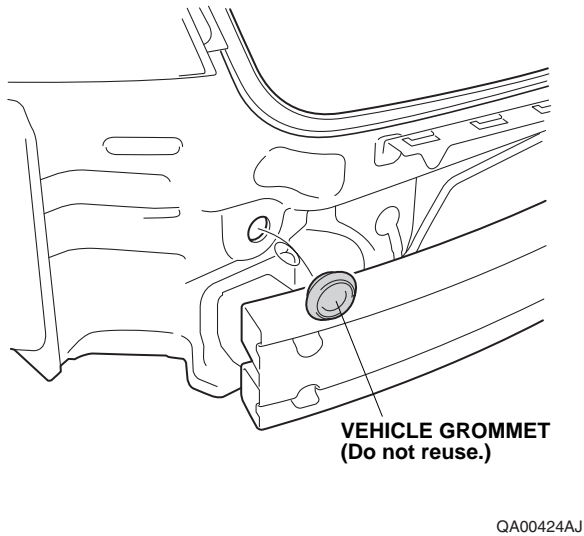

34. Using electrical tape, attach the steel wire to the backup sensor harness 8-pin connector. Route the backup sensor harness as shown.

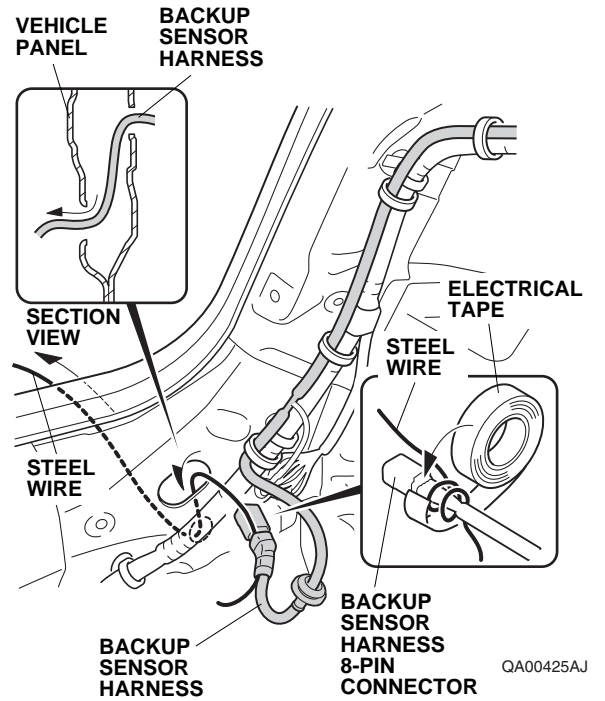

35. Secure the backup sensor harness grommet to the vehicle panel. Remove the electrical tape and steel wire.
- NOTE:** Install the backup sensor harness by holding the grommet. Make sure to check that the grommet is properly secured.

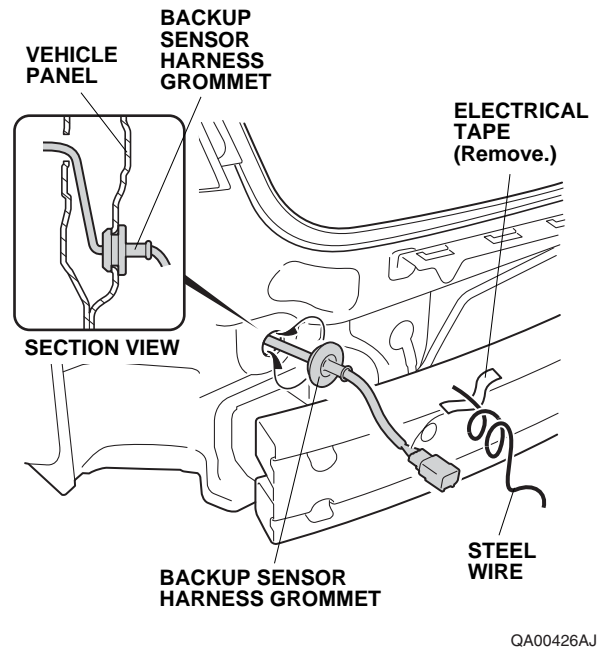

## Installing the Backup Sensors

36. Mark the inside of the rear bumper:

- Locate the four scribe marks on the inside of the rear bumper at the center and on each side.
- Using a pushpin, pierce the rear bumper at the top and center of the four scribe marks.  
NOTE: Make sure to pierce the scribe marks at a right angle to the rear bumper.

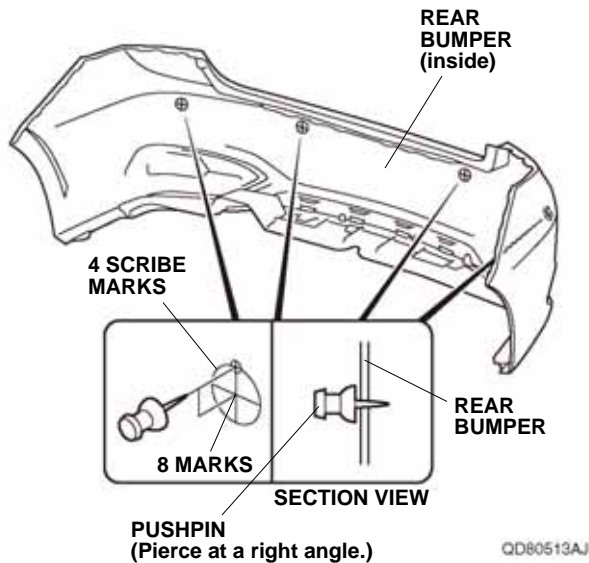

37. While wearing eye protection, drill the eight pierced marks with a 3 mm drill bit from outside of the rear bumper.  
NOTE: Make sure to drill at a right angle to the rear bumper.

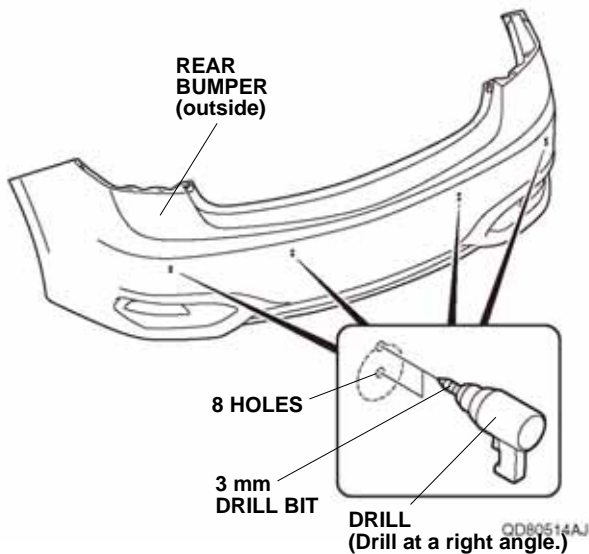

38. While wearing eye protection, and drilling from outside of the rear bumper, enlarge the two outer 3 mm lower holes to 24 mm using a 24 mm hole saw.  
NOTE: Make sure to drill at a right angle to the rear bumper. Remove any burrs.

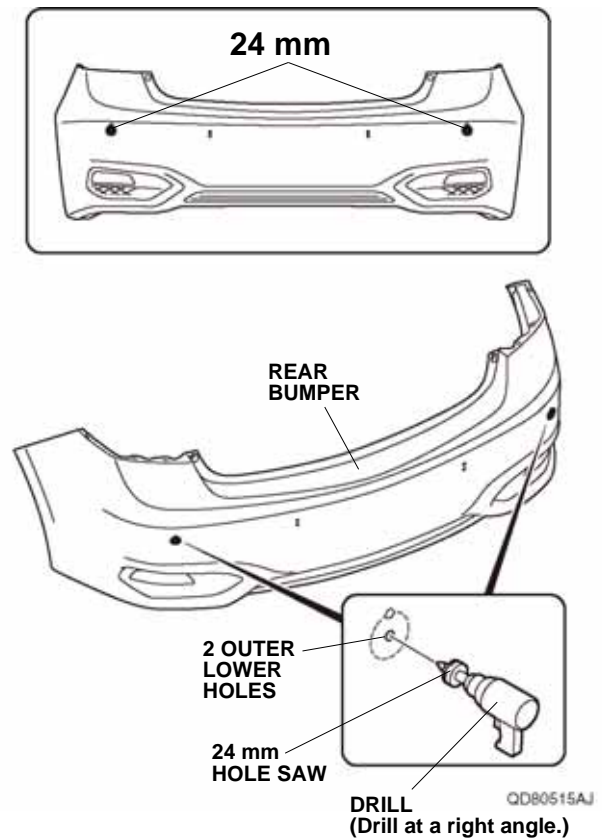

39. While wearing eye protection, and drilling from outside of the rear bumper, enlarge the two inner 3 mm lower holes to 26 mm using a 26 mm hole saw. NOTE: Make sure to drill at a right angle to the rear bumper. Remove any burrs.

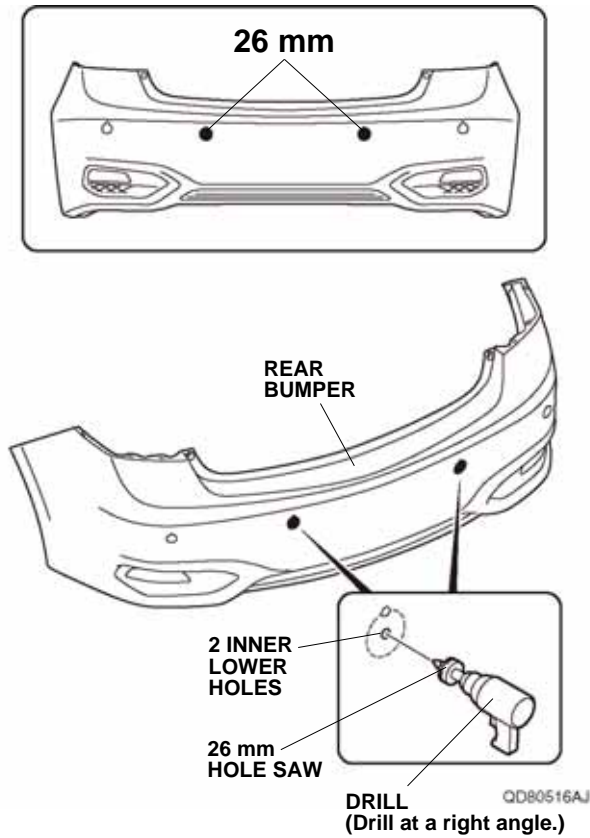

40. Insert the two center sensors (blue) to the rear bumper, and secure them with the two center sensor clips as shown.

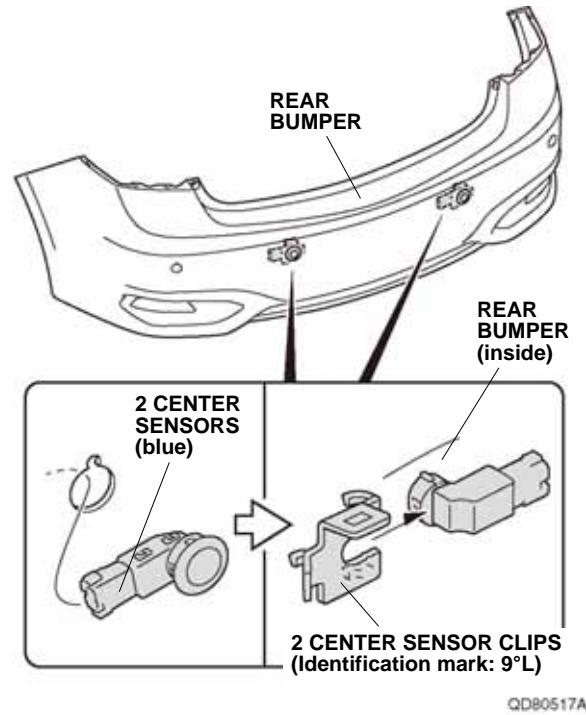

41. Insert the two corner sensors (white) to the rear bumper, and secure them with the two corner sensor clips as shown.

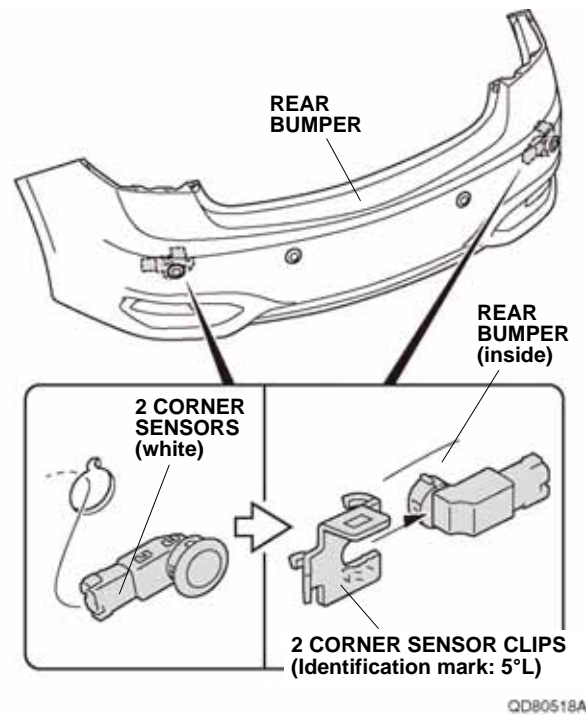

42. Plug the four subharness 2-pin connectors into the two center sensors (blue) and the two corner sensors (white).

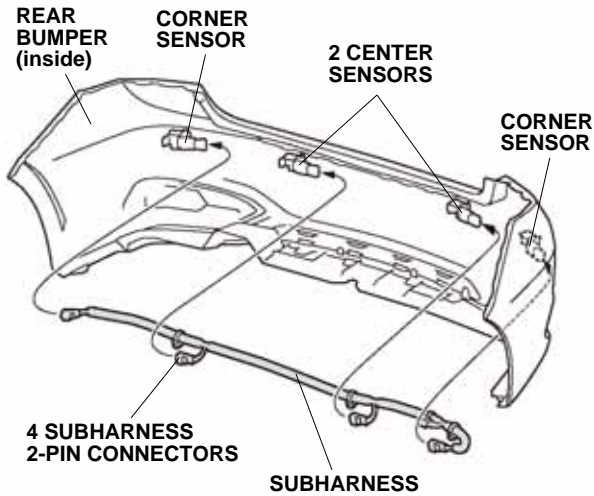

QD80519AJ

43. Secure the three subharness clips to the three sensor clips.

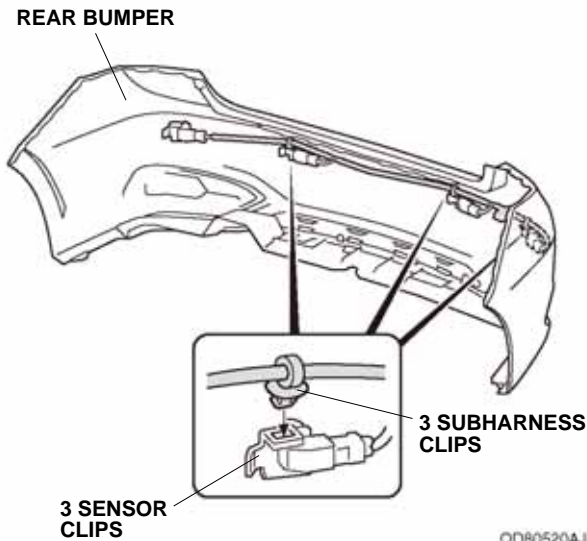

QD80520AJ

44. Using isopropyl alcohol on a shop towel, thoroughly clean the rear bumper where the aluminum tape will attach.

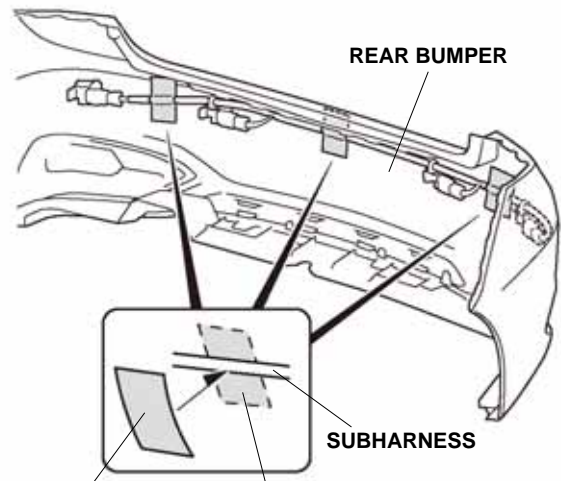

QD80521AJ

45. Secure the subharness to the rear bumper with the three aluminum tapes as shown.
46. With the help of an assistant, bring the rear bumper close to the vehicle, and plug the subharness 8-pin connector into the backup sensor harness 8-pin connector. Reinstall the rear bumper.

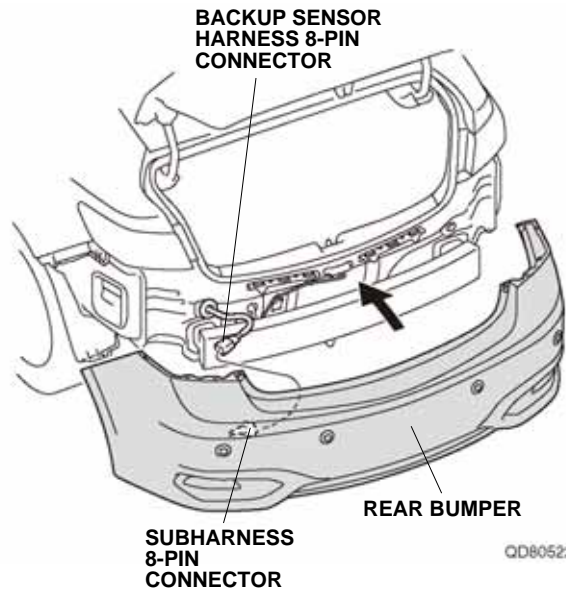

QD80522AJ

47. Check that all wire harnesses are routed properly and that all connectors are plugged in.
48. Reinstall all removed parts.
49. Reconnect the negative cable to the battery.
50. Press and hold the radio power button for two seconds to restore the radio and navi (if equipped) system functions.
51. Reset the clock on vehicles without navigation.

### **Check the Operation of the Backup Sensor**

52. Check that the backup sensors work properly as described in the Accessory User's Information Manual supplied with the backup sensor attachment kit.

### **Adjust the Volume Control**

The factory setting is maximum volume. After confirming the operation, turn the volume control knob to the appropriate level, using a small flat-tip screwdriver. Do not force the adjuster as it could damage the unit.

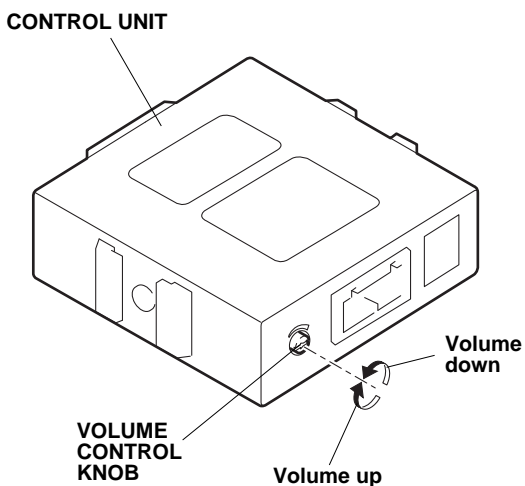

771108AB