



INSTALLATION INSTRUCTIONS

Accessory

STEERING WHEEL
P/N 08U97-TY2-200

Application

2015 RLX

Publications No.

VERSION 1

Issue Date

JAN 2015

PARTS LIST

Steering wheel



2 TORX bolts



Steering wheel bolt



Important Information



TOOLS AND SUPPLIES REQUIRED

Phillips screwdriver
10 mm Open end wrench
10 mm Hex bit
Ratchet
T30 TORX bit
Torque wrench
Steering wheel puller
HDS/MVCI

Illustration of the Steering Wheel in the Vehicle



STEERING WHEEL

QD72401AJ

INSTALLATION

Client Information: The information in this installation instruction is intended for use only by skilled technicians who have the proper tools, equipment, and training to correctly and safely add equipment to your vehicle. These procedures should not be attempted by "do-it-yourselfers."

NOTE:

- Observe all safety notes and precautions in the Service Manual and in these Installation Instructions.
 - Do not damage the vehicle.
 - After installing the steering wheel, you must align the steering wheel spoke angle to the straight ahead position by adjusting the front toe.
1. Turn the steering wheel so the front wheels are in the straight ahead position.
 2. Disconnect the negative cable from the battery, then wait at least 3 minutes before starting work.

- Remove the two TORX bolts. Unplug the driver's airbag inflator connectors and the horn switch connector.
NOTE: Be careful not to damage the connectors.

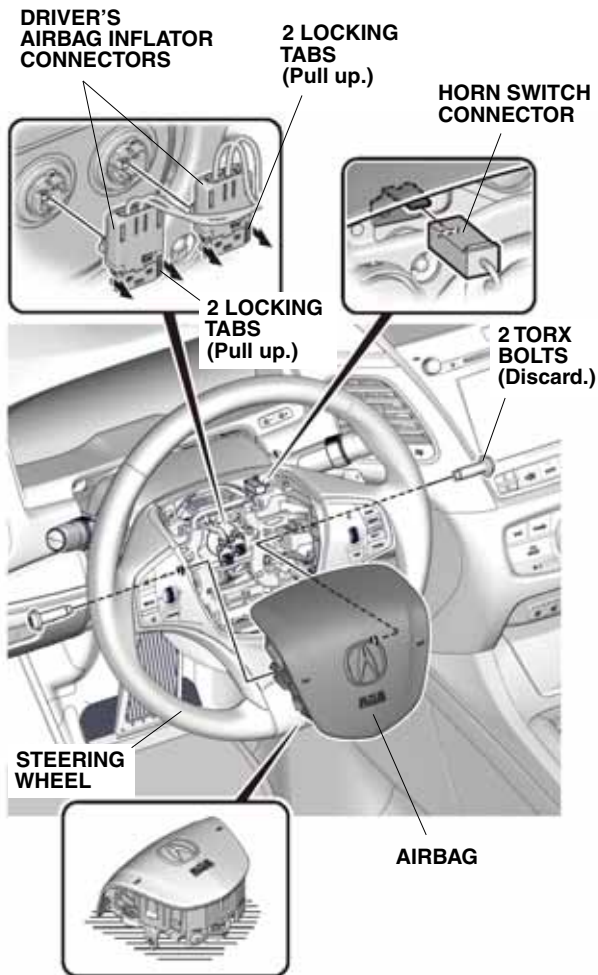

QD72402AJ

- Remove the airbag. Do not drop the removed airbag or hit it on an object. Place the removed airbag on a safe place with the pad surface facing upward.

- Remove the steering wheel switches ground..

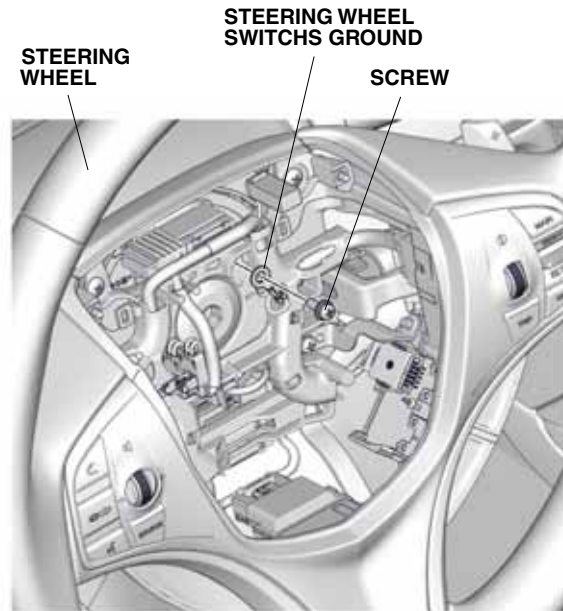

QD72403AJ

- With the front wheels aligned in the straight forward position, loosen the steering wheel bolt.

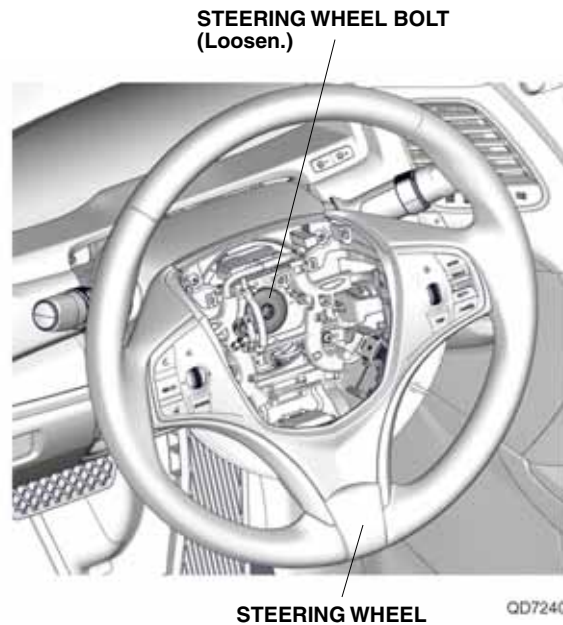

QD72404AJ

- With the front wheels aligned in the straight forward position, unplug the cable reel connector from the cable reel, and remove the vehicle harness (retaining tab).

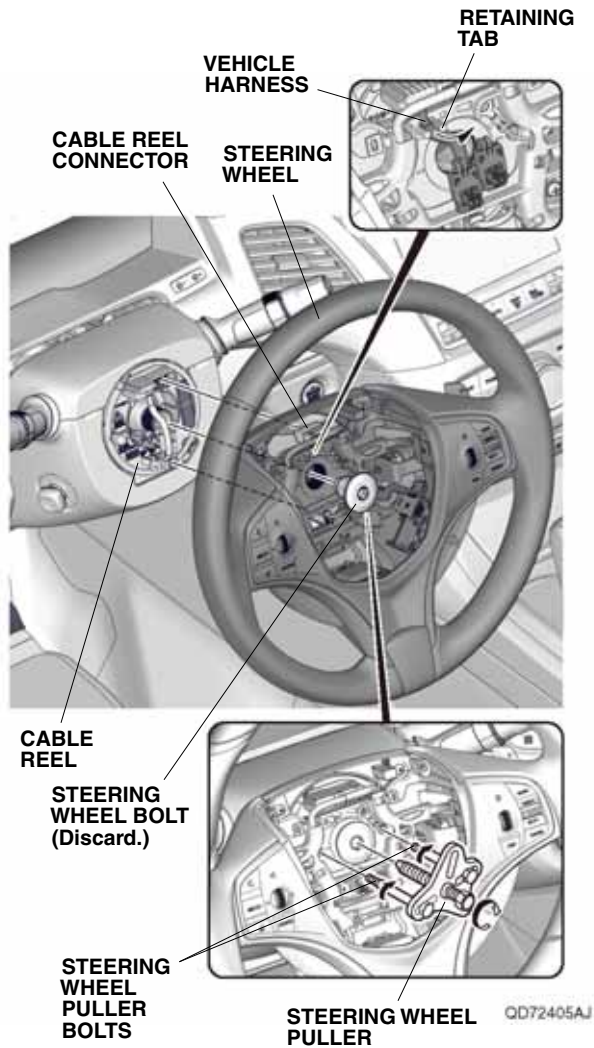

- Using a steering wheel puller, release the steering wheel. Do not thread the steering wheel puller bolts in more than 5 mm (0.20 in.). When removing the vehicle steering wheel, take care not to move the front wheels.
- Remove the steering wheel bolt, then remove the steering wheel.

- Remove the steering wheel rear cover.

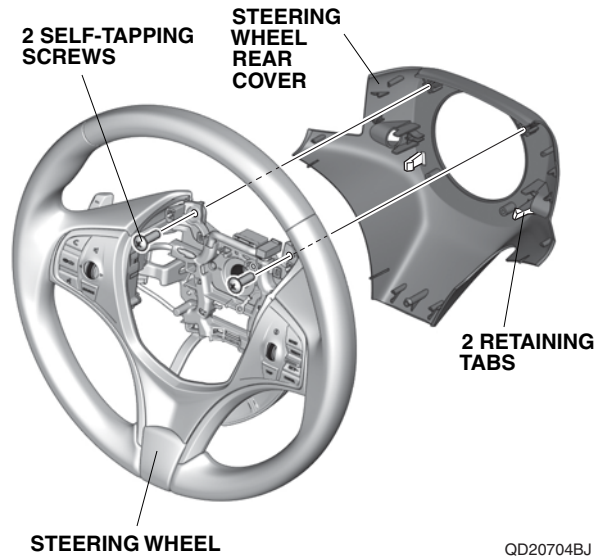

- Remove the left and right paddle shifters from the steering wheel (four screws, and unplug the vehicle connectors).

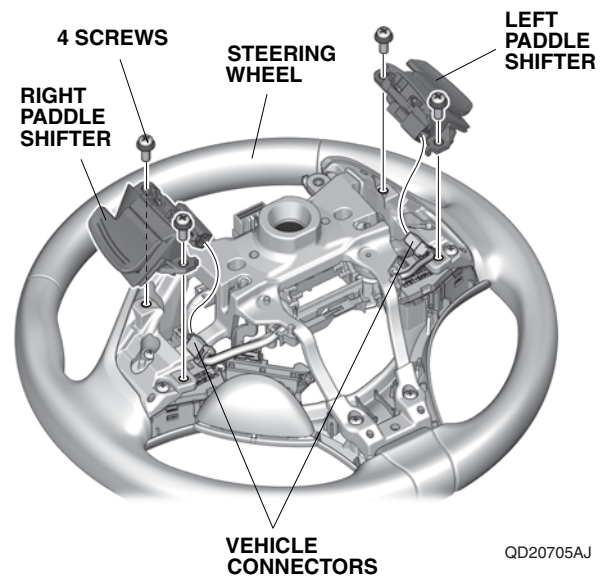

12. Remove the steering commander switch assembly.

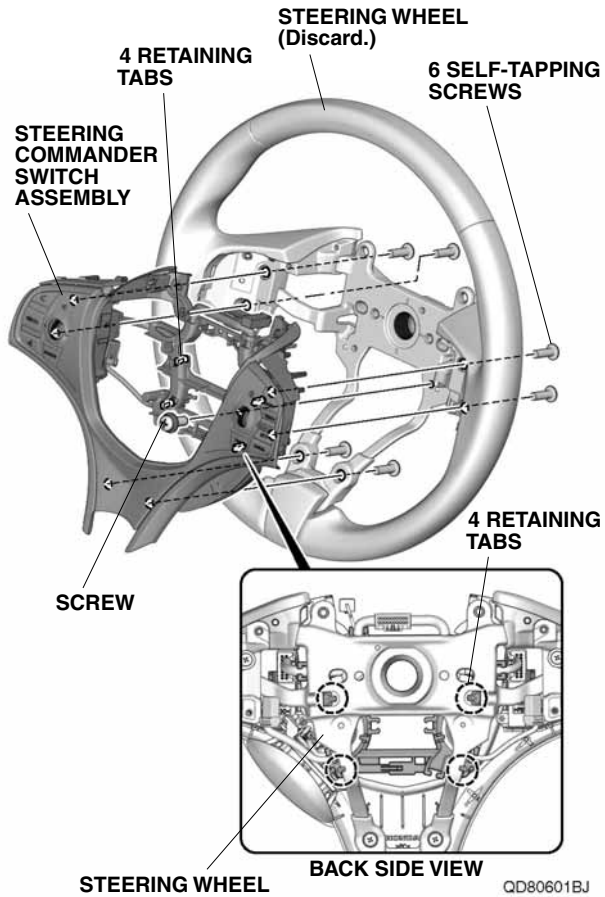

13. Install the steering commander switch assembly to the new steering wheel with the six self-tapping screws and one screw.

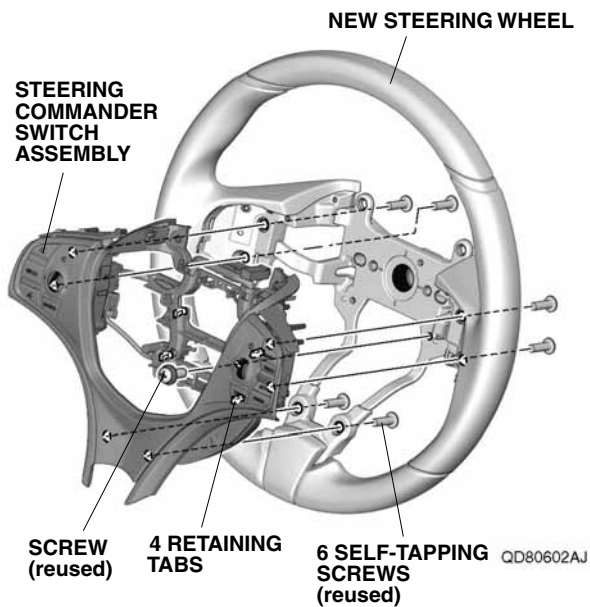

14. Install the left and right paddle shifters to the new steering wheel with four screws. Plug the vehicle connectors into the left and right paddle shifters.

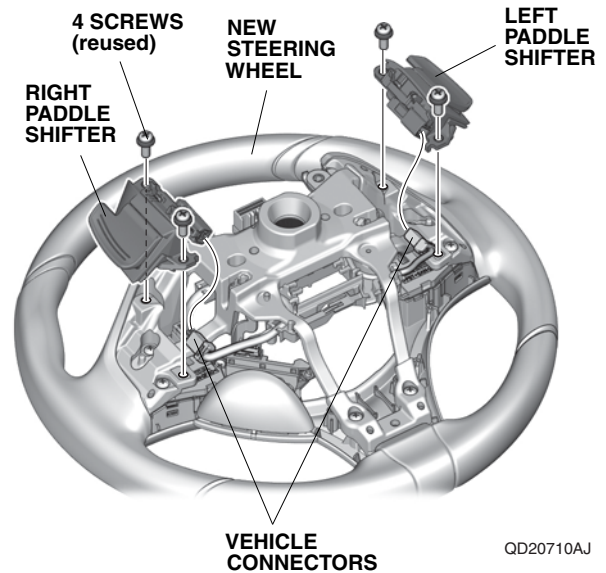

15. Install the steering wheel rear cover to the new steering wheel with two self-tapping screws.

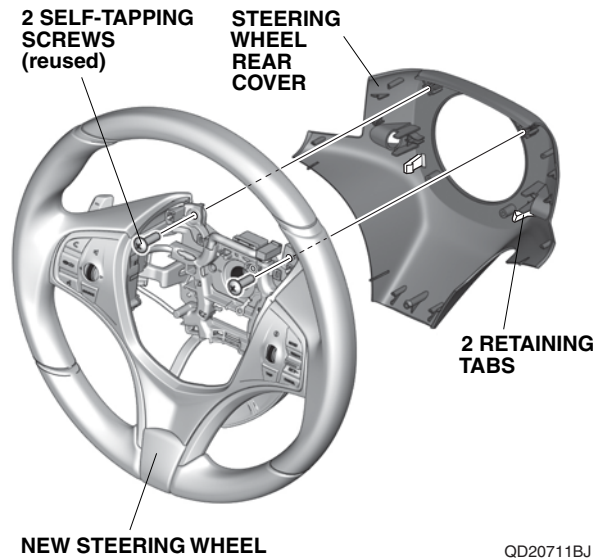

16. Before installing the steering wheel, make sure the front wheels are pointing straight ahead, then center the cable reel. Do this by first rotating the cable reel clockwise until it stops, then rotate it counterclockwise about three full turns. The arrow mark on the cable reel should point straight up.

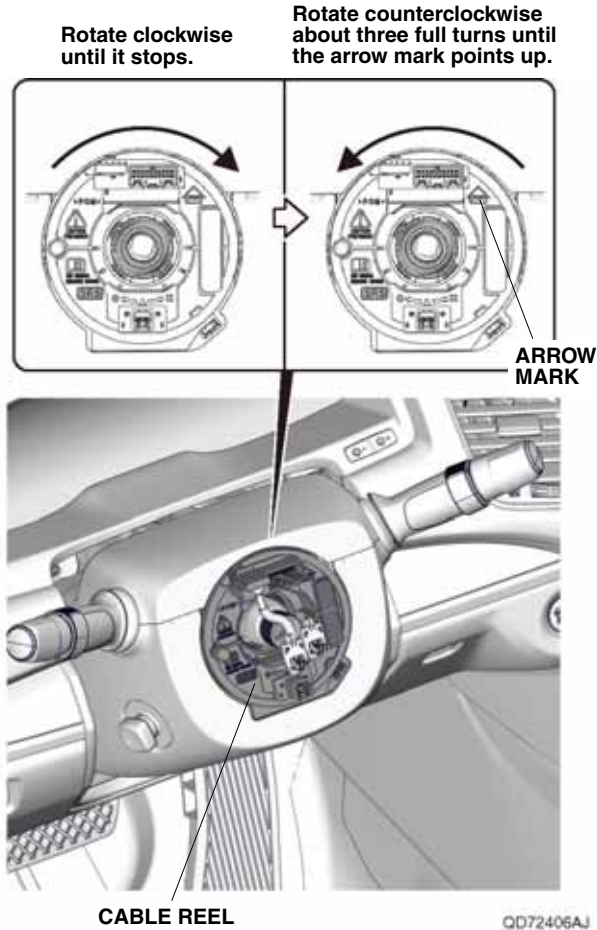

17. Install the new steering wheel to the steering column shaft in the straight ahead position:
- Route the driver's airbag inflator connectors through the opening in the new steering wheel.
 - Plug the cable reel connector to the cable reel.
 - Check that the wire harnesses are not pinched.

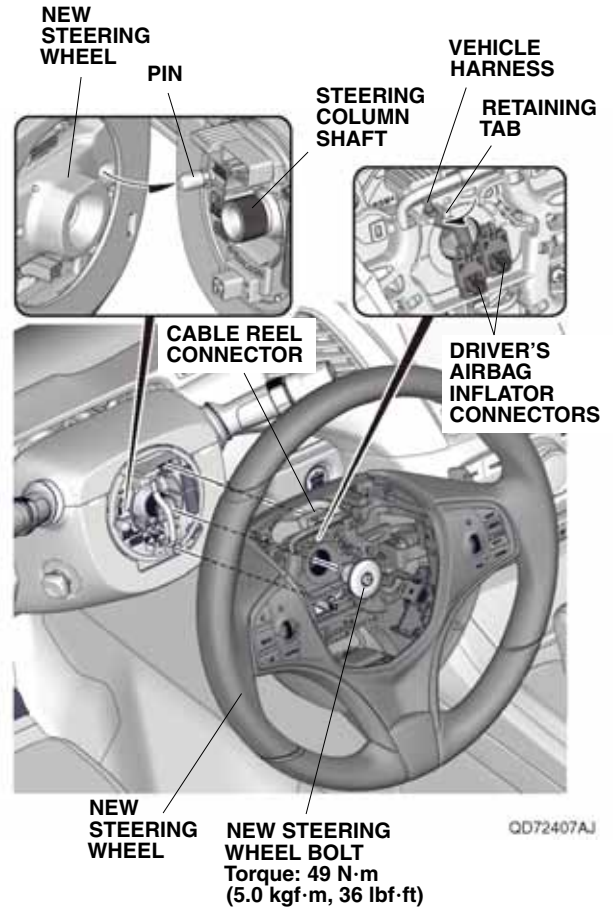

18. Install the **new** steering wheel bolt. Torque the steering wheel bolt to 49 N·m (36 lbf·ft).
NOTE: The **new** steering wheel bolt must be torqued to specifications within 5 minutes.

19. Install the steering wheel switches ground.

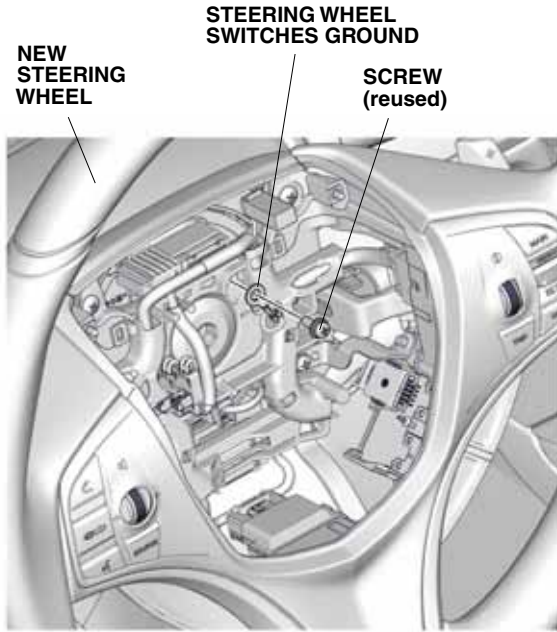

QD72408AJ

20. Install the airbag on the new steering wheel with two new TORX bolts, plug-in the driver's airbag inflator connectors and the horn switch connector.

- Alternately tighten the right and left TORX bolts so that the clearances on the right and left sides between the horn pad and the steering wheel are equal. Torque the TORX bolts to 9.4 N-m (6.9 lbf-ft).
- TORX bolts are coated with non-hardening thread lock sealant, so they cannot be reused. When installing the steering wheel, be sure to replace the TORX bolts with the ones included in this kit.

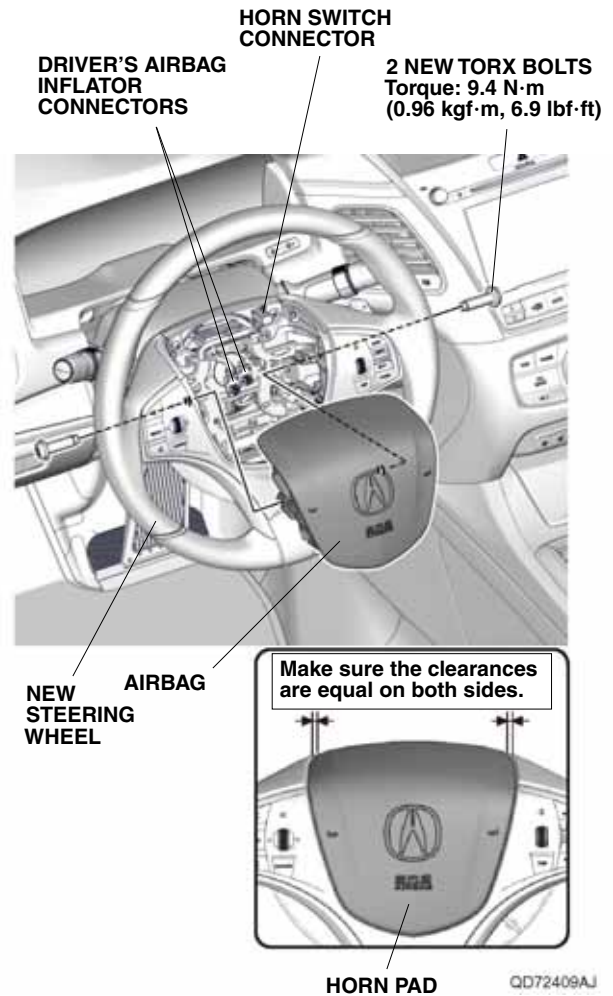

QD72409AJ

21. Check that all wire harnesses are routed properly and all connectors are plugged in.
22. Reconnect the negative cable to the battery.
23. Connect the HDS/MVCI, and clear any DTCs.
24. Inspect the following items.
 - Press the engine start/stop button to the ON mode: the SRS indicator should come on for about 6 seconds and then go off.
 - Make sure the horn and steering wheel switches work properly.

NOTE: If something isn't working as designed, refer to the troubleshooting section in the Service Manual.

25. Press and hold the radio power button for two seconds to restore the radio and navi (if equipped) system functions.
26. Reset the clock.
27. Restore the systems back to normal operation as described in the Service Manual if necessary.
28. Make sure the steering wheel is in the straight ahead position with the front wheels. If the spoke angle of the steering wheel is not in the straight ahead position with the front wheels, adjust the front toe as described in the Service Manual.