



INSTALLATION INSTRUCTIONS

Accessory
ENGINE BLOCK HEATER
P/N 08T44-SNA-101

Application
2015 ILX
(2.0L)

Publications No.
BII 51699
Issue Date
MAY 2014

PARTS LIST

Engine block heater

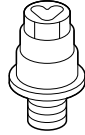

Aluminum washer



Heater harness

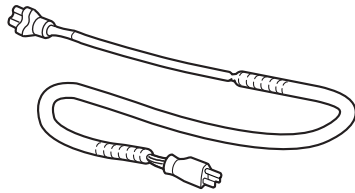

Protective cap

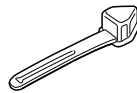

12 Black wire ties
(5 Not used)

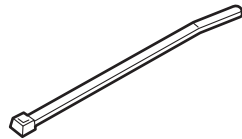

7 Wire ties with clip
(5 Not used)

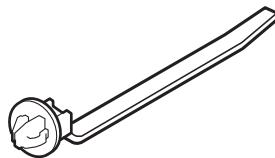

5 White wire ties

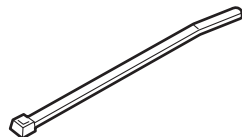

TOOLS AND SUPPLIES REQUIRED

Phillips screwdriver

Ratchet

8 mm, 10 mm, 19 mm, and 24 mm Sockets

Torque wrench

Diagonal cutters

Heavy gloves

Drain pan

Tape measure

White marker

Coolant (Acura Long-Life Antifreeze/Coolant Type 2)

Eye protection (face shield, safety goggles, etc.)

Blanket

Drill

3 mm and 5 mm Drill bits

Pushpin

Fender cover

Tape

File

Shop towel

The following tool is available through the Honda Tool and Equipment Program. On the iN, click on: Service > Service Bay > Tool and Equipment Program, then enter the number under "Search". Or, call 888-424-6857.

- Trim Tool Set (T/N SOJATP2014)

Illustration of the Engine Block Heater in the Vehicle

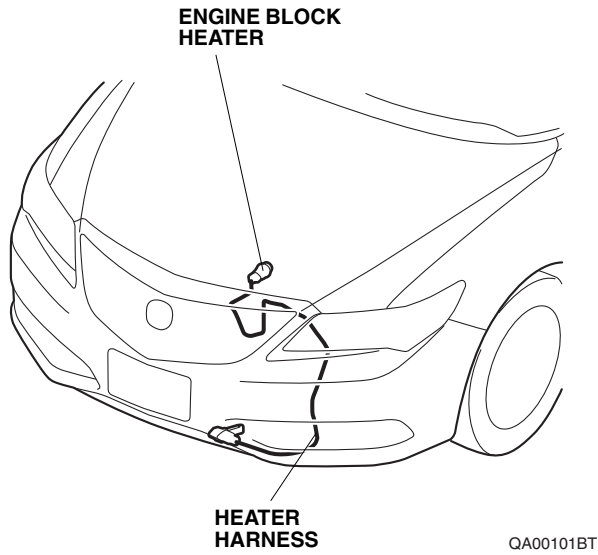

INSTALLATION

Client Information: The information in this installation instruction is intended for use only by skilled technicians who have the proper tools, equipment, and training to correctly and safely add equipment to your vehicle. These procedures should not be attempted by “do-it-yourselfers.”

NOTE:

- Always use Acura Long-Life Antifreeze/Coolant Type 2. Using a non-Acura coolant can result in corrosion, causing the cooling system to malfunction or fail.
 - To avoid burning out the element, do not operate the engine block heater until it is installed in the vehicle and you have added coolant.
1. Disconnect the negative cable from the battery.
 2. Allow the engine and all cooling system components to cool down.

3. Place a clean drain pan under the radiator drain plug, then remove the drain plug from the bottom of the radiator to drain the coolant. Remove the radiator cap to increase the flow.

NOTICE: Radiator coolant will damage the paint. Quickly rinse any spilled coolant from the paint.

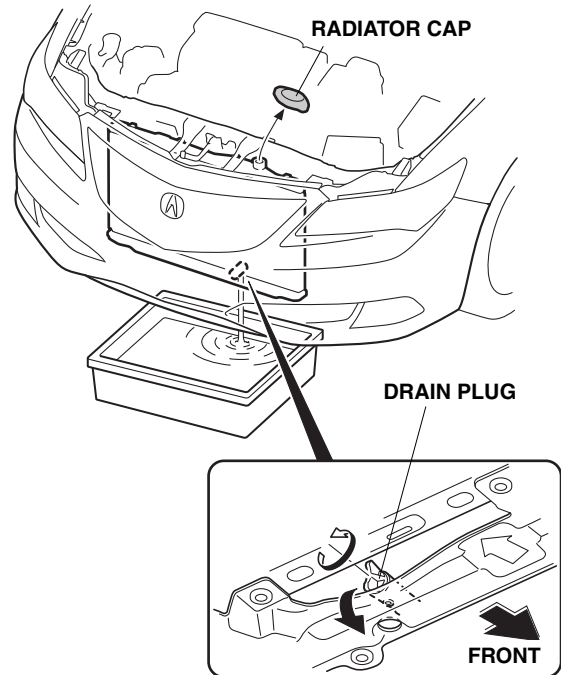

4. Drain the coolant completely, then reinstall the radiator cap.

5. Remove the front bumper:
 - Attach tape to the areas shown on each side.
 - Wrap a shop towel around the hood latch.

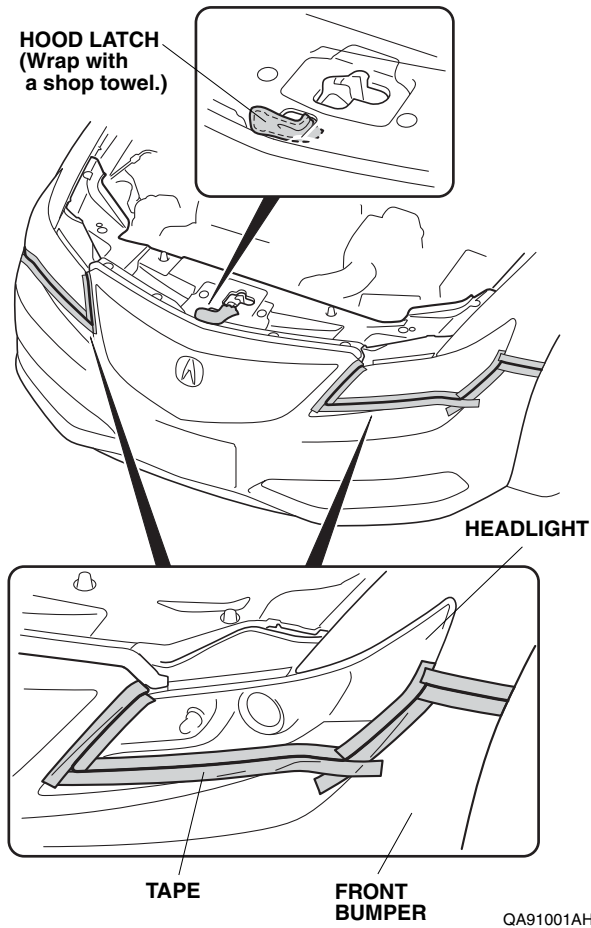

- Remove the front bulkhead cover (four clips and four long clips).

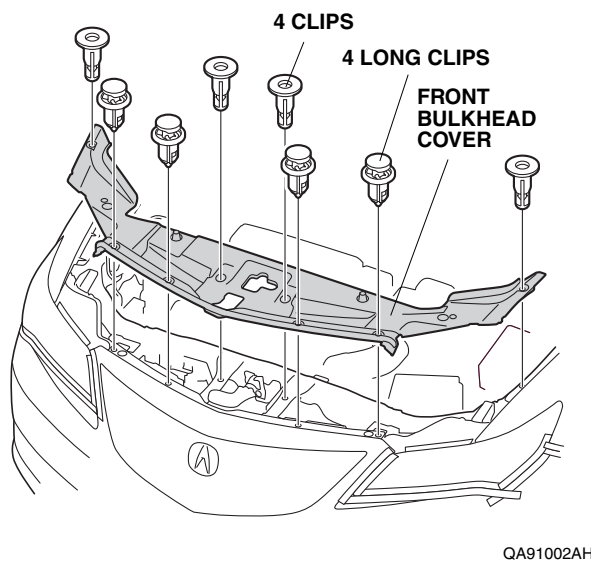

- Remove three medium clips.

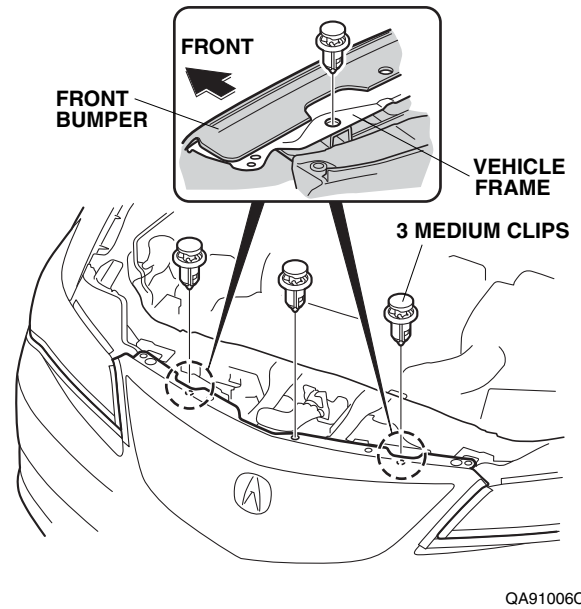

- Remove 2 self-tapping screws, 2 bolts, 2 short clips, and 12 medium clips.

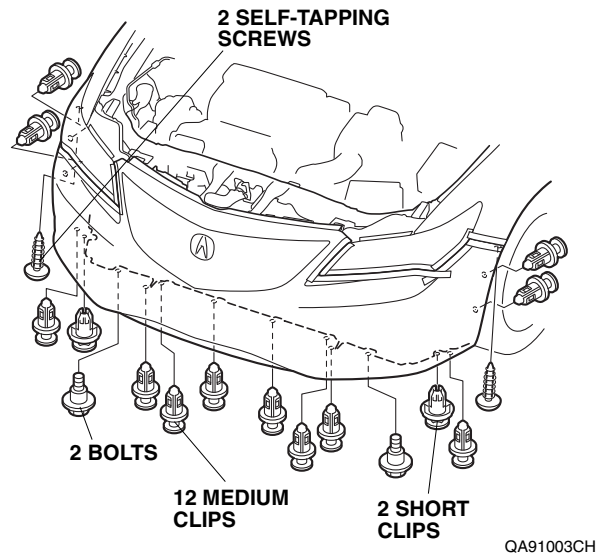

- Release four retaining tabs on each side.

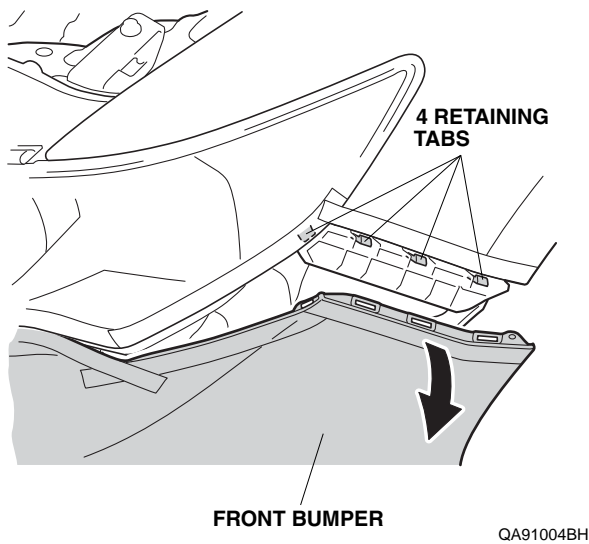

- With the help of an assistant, release four retaining tabs on each side.

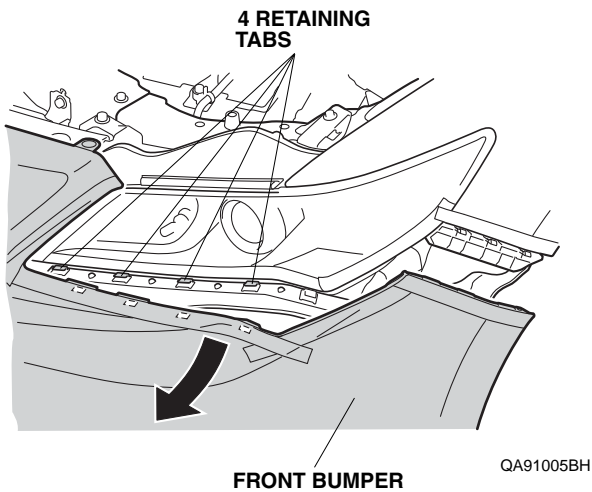

- With the help of an assistant, remove the front bumper (unplug the vehicle connector, and release five pins). Place the front bumper on a blanket to prevent damage.

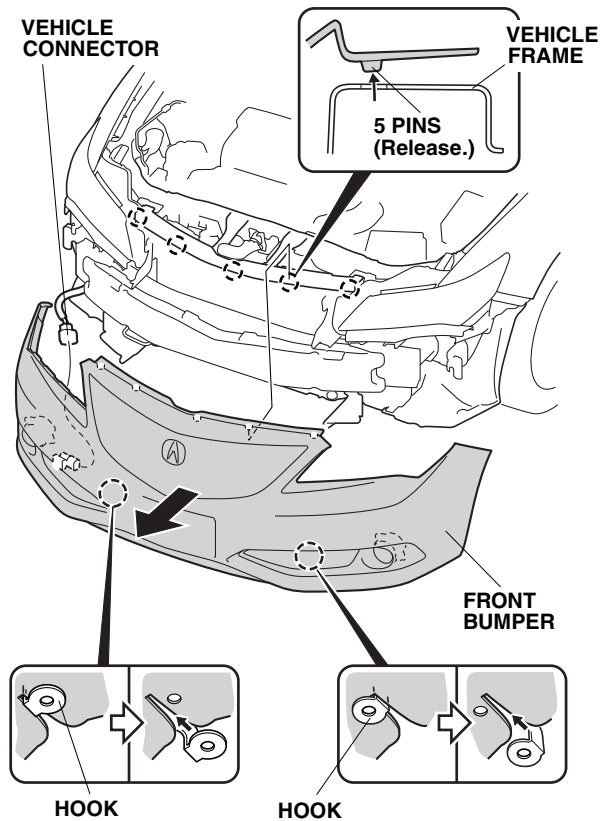

6. Open the positive cable cover and disconnect the positive (+) battery cable from the battery.

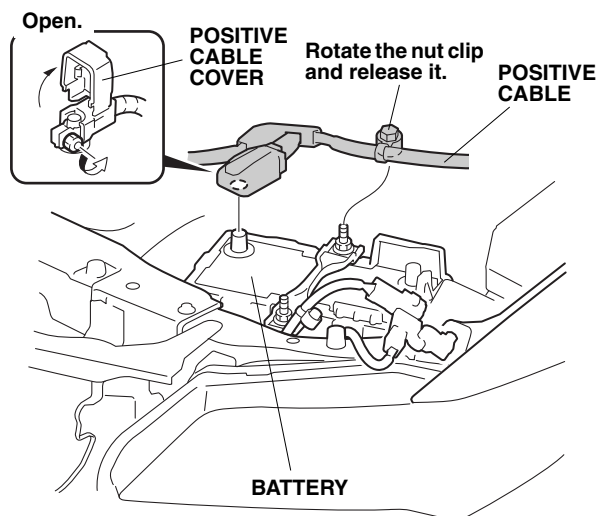

- Remove the battery (two nuts, battery plate, battery upper cover, battery, and battery under cover).

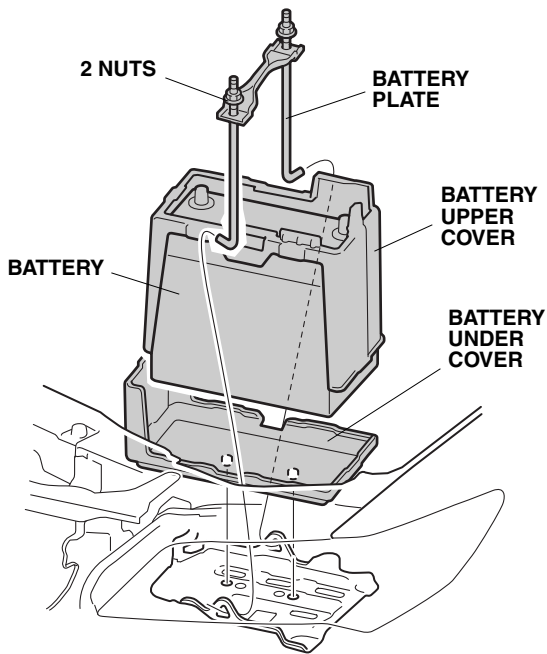

QA00103AT

- Using a tape measure, measure the heater harness and mark it at the A, B, C, D, and E points shown.

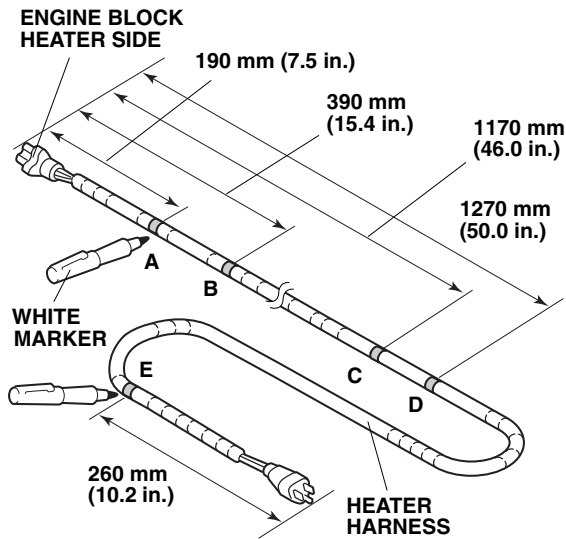

QA00104BT

- Install two wire ties with clip to the heater harness at points C and D.

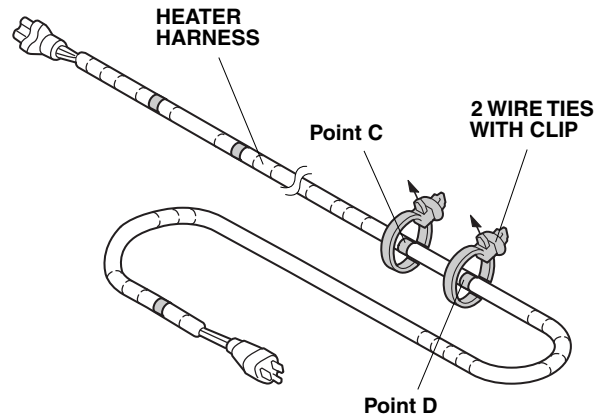

QA00105AT

- Locate and remove the drain bolt and washer. Coolant remaining in the engine jackets flows out of the hole when the bolt is removed. Retain the bolt; it will be used if the block heater removed. NOTE: Use a new washer if the drain bolt is reinstalled.

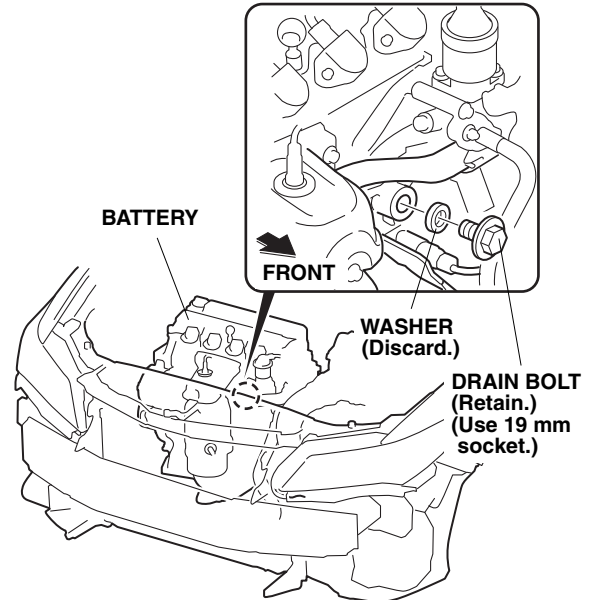

QA00106AT

11. Install the engine block heater with the aluminum washer into the bolt hole using a 24 mm socket and a torque wrench. Torque the engine block heater to 85 N·m (8.5 kgf·m, 63 lbf·ft).

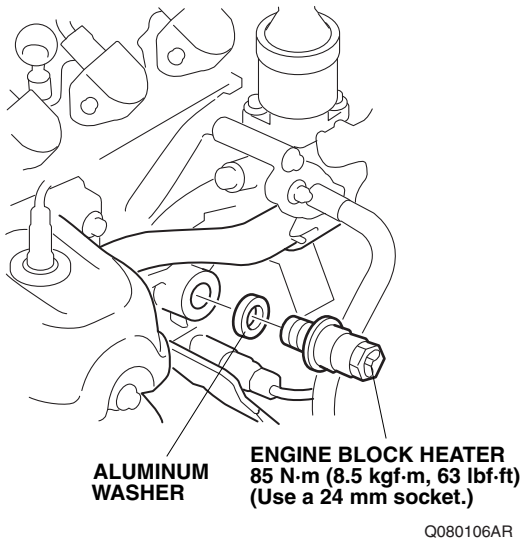

12. Plug the connector end of the heater harness into the engine block heater. Make sure the heater harness connector is fully seated in the engine block heater.

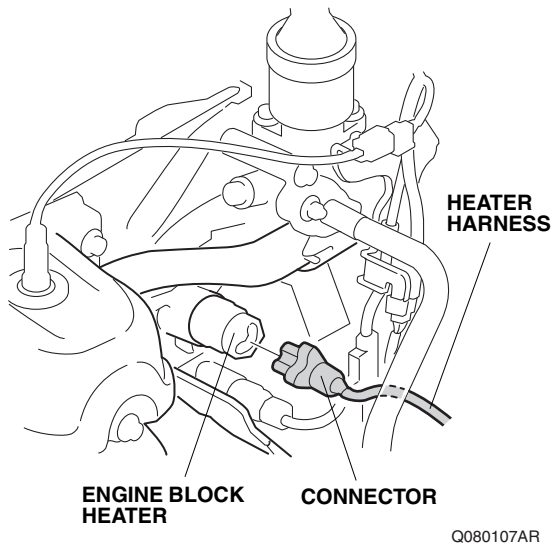

13. Secure the heater harness to the vehicle bracket with one white wire tie at the white mark (point A).

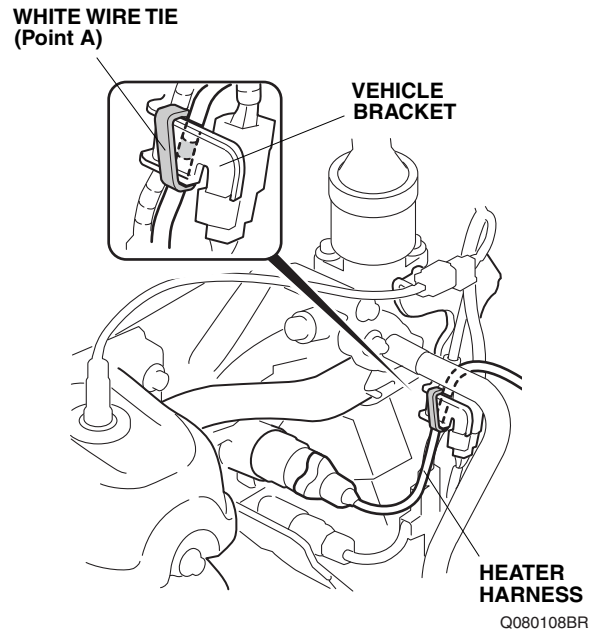

14. Route the heater harness as shown. Secure the heater harness to the fan shroud rib with one white wire tie at the white mark (point B).

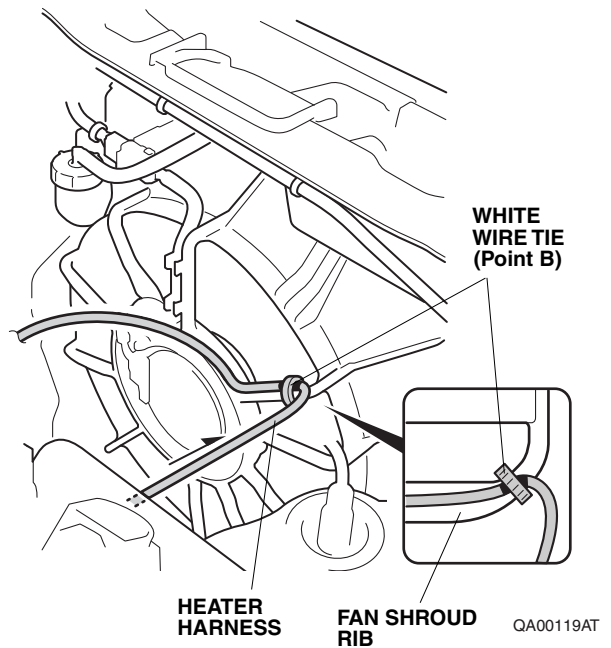

15. Route the heater harness as shown.

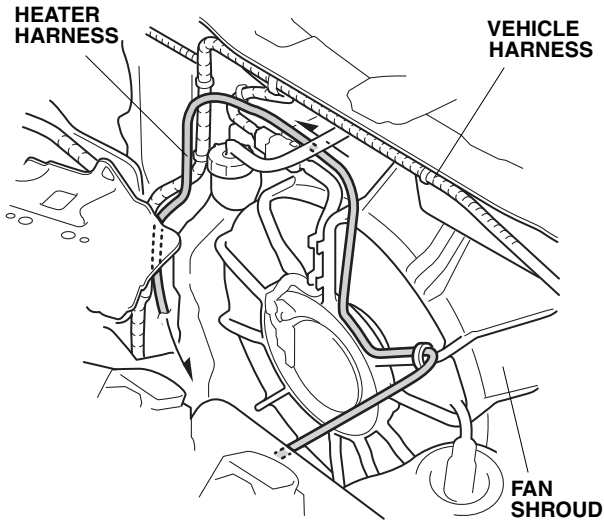

QA00107AT

16. Using two black wire ties and three white wire ties, secure the heater harness to the fan shroud rib and vehicle harness.

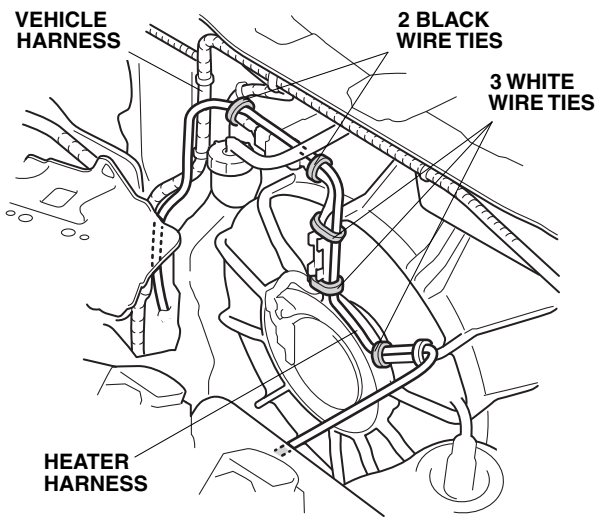

QA00108AT

17. Route the heater harness under the vehicle frame as shown.

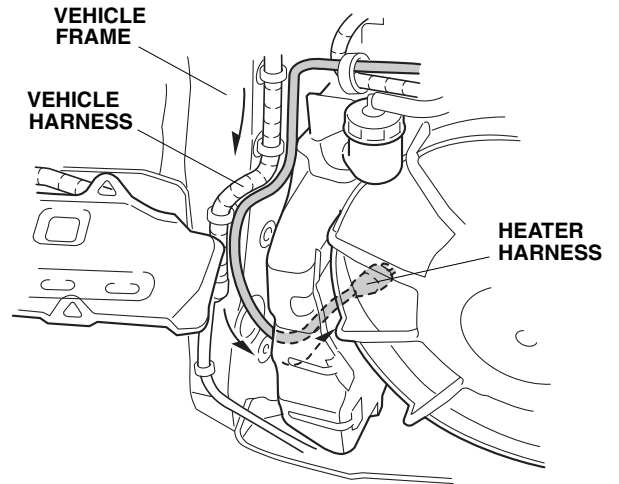

QA00109AT

18. Using two black wire ties, secure the heater harness to the vehicle harness.

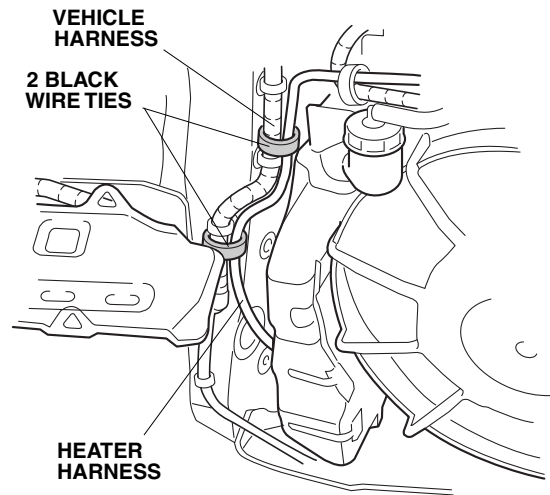

QA00110AT

19. Route the heater harness as shown. Secure the two clips (points C and D) on the heater harness to the vehicle panel.

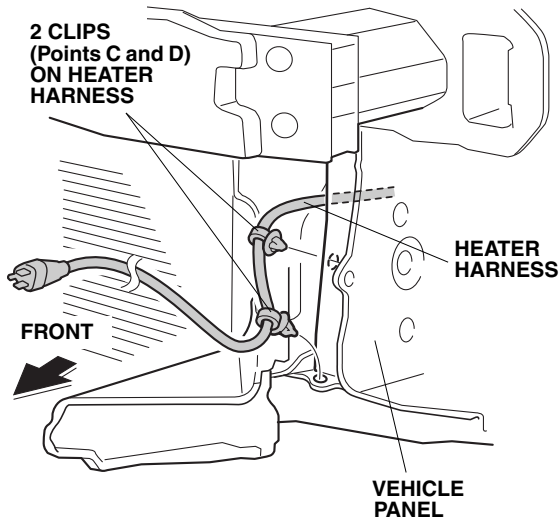

QA00111BT

20. Using a white marker, mark the vehicle panel at the measurements shown.

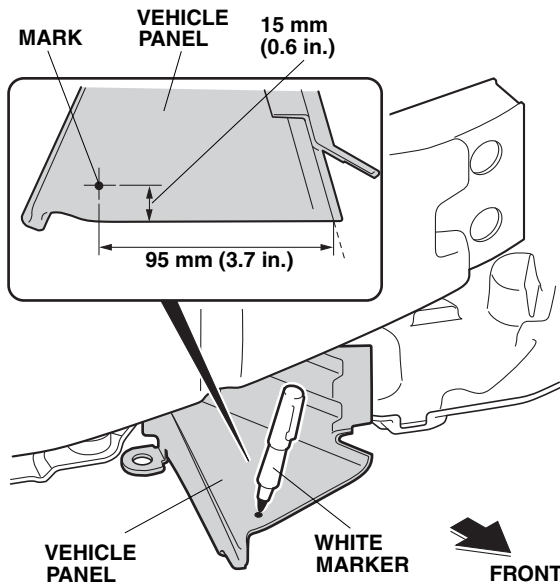

QA00130AT

21. Using a pushpin, pierce the mark on the vehicle panel.

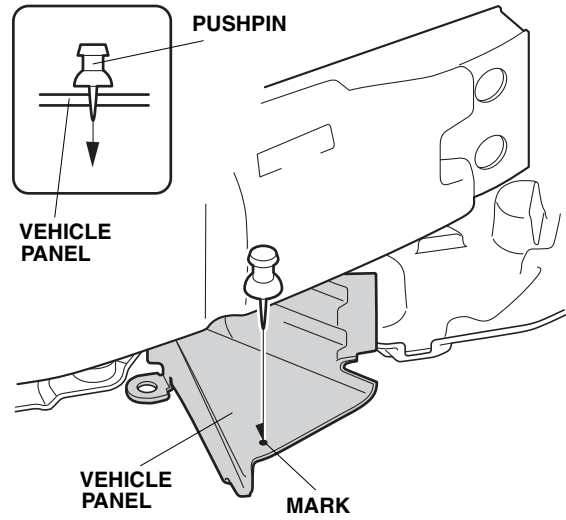

QA00131AT

22. While wearing eye protection, drill the pierced mark with a 3 mm drill bit, then enlarge the hole with a 5 mm drill bit. Remove any burrs.

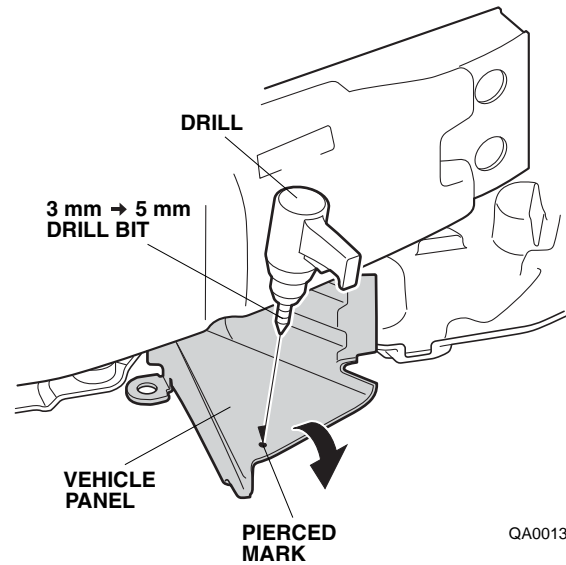

QA00132AT

23. Secure the heater harness to the vehicle panel hole with one black wire tie at the white mark (point E).

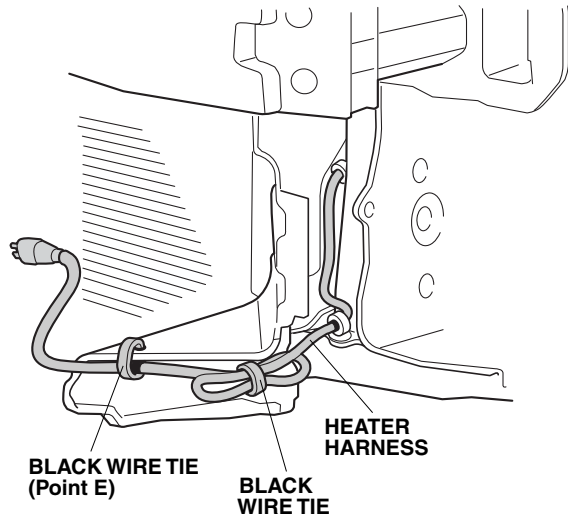

QA00112CT

24. Bundle the excess heater harness and attach one black wire tie as shown.
25. Using a white marker, mark the front bumper at the measurements shown.

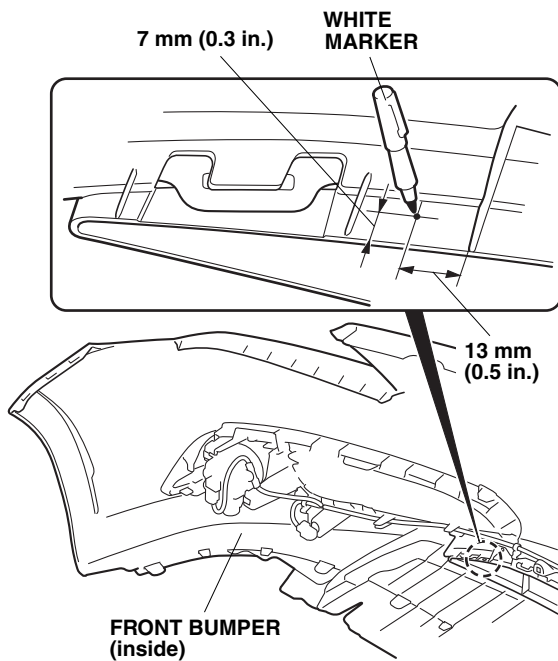

QA00133AT

26. Using a pushpin, pierce the mark on the front bumper.

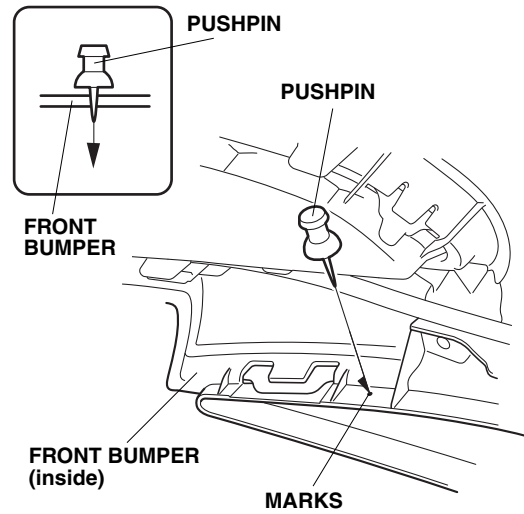

QA00134AT

27. While wearing eye protection, drill the pierced mark with a 3 mm drill bit, then enlarge the hole with a 5 mm drill bit. Remove any burrs. To prevent drilling through the inner panel, wrap tape around the drill bit 10 mm (0.4 in.) away from the tip or use a drill stop.

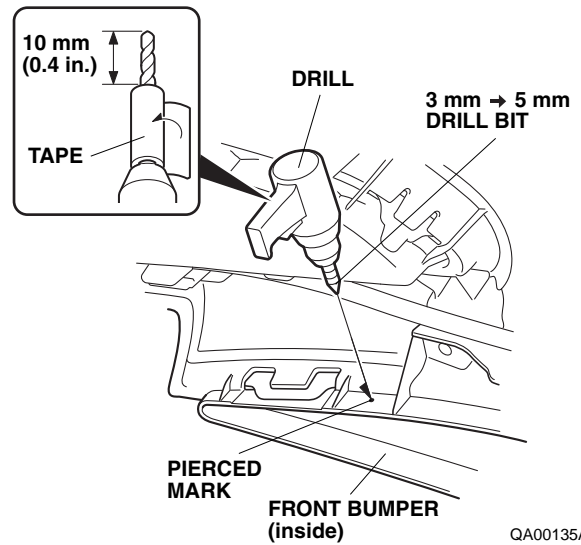

QA00135AT

- With the help of an assistant, bring the front bumper close to the vehicle. Attach the heater harness to the drilled hole in the front bumper with one loosely-installed black wire tie, then reinstall the front bumper.

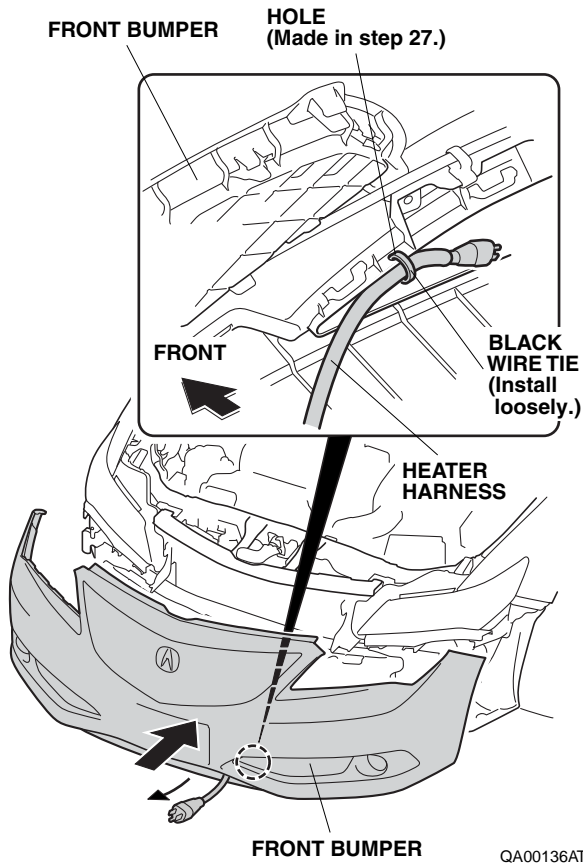

- Tighten the black wire tie installed in step 28.

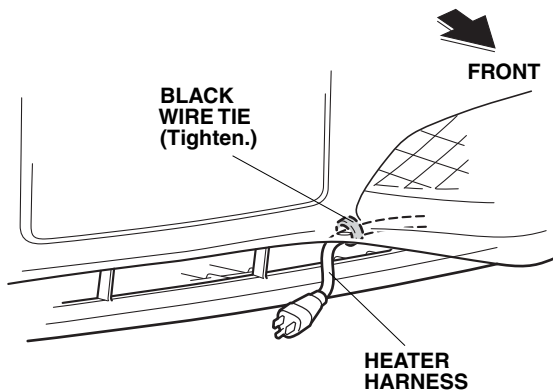

- Attach the protective cap to the front bumper, and plug the heater harness connector into the protective cap.

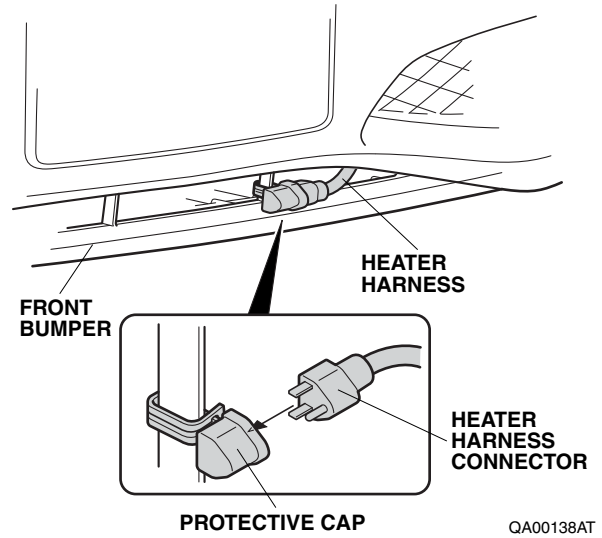

- Reinstall all removed parts.
- Reinstall the radiator drain plug.
- Remove the radiator cap and fill the system with the recommended coolant. Follow the instructions in the Service Manual to fill the cooling system and check for leaks. Particularly check that there is no leak around the engine block heater.
- Make sure that the heater harness is routed properly and all connectors are plugged in.
- Reinstall the radiator cap.
- Put the drain bolt (removed in step 10) in the glove box.
- Reconnect the negative cable to the battery.
- Press and hold the radio power button for two seconds to restore radio and navi (if equipped) system functions.
- Reset the clock.