



INSTALLATION INSTRUCTIONS

Accessory

**STEERING WHEEL
P/N 08U97-TL2-220**

Application

2014 TSX

Publications No.

BII 50208

Issue Date

SEPT 2013

PARTS LIST

Steering wheel



2 TORX bolts

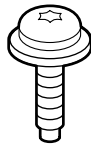

Information Sheet

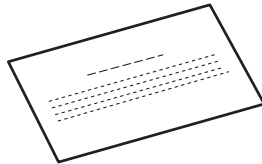

TOOLS AND SUPPLIES REQUIRED

- Phillips screwdriver
- 14 mm T-handle wrench
- T30 TORX wrench
- Steering wheel puller
- Service manual
- Torque wrench
- Plastic trim tool (T/N: SILTRIMTL10)
- 10 mm Wrench
- Adhesive steering wheel offset gauge sticker (T/N: 07AAJ-001A300)

INSTALLATION

Client Information: The information in this installation instruction is intended for use only by skilled technicians who have the proper tools, equipment, and training to correctly and safely add equipment to your vehicle. These procedures should not be attempted by "do-it-yourselfers."

NOTE: Observe all safety notes and precautions described in the service manual in addition to those described in this installation instruction.

1. Make sure you have the anti-theft codes for the audio and navigation system (if equipped), then write down the audio presets.
2. Disconnect the negative cable from the battery, and wait at least 3 minutes before you start to install the steering wheel.
3. Remove the access panel from the underside of the steering wheel.

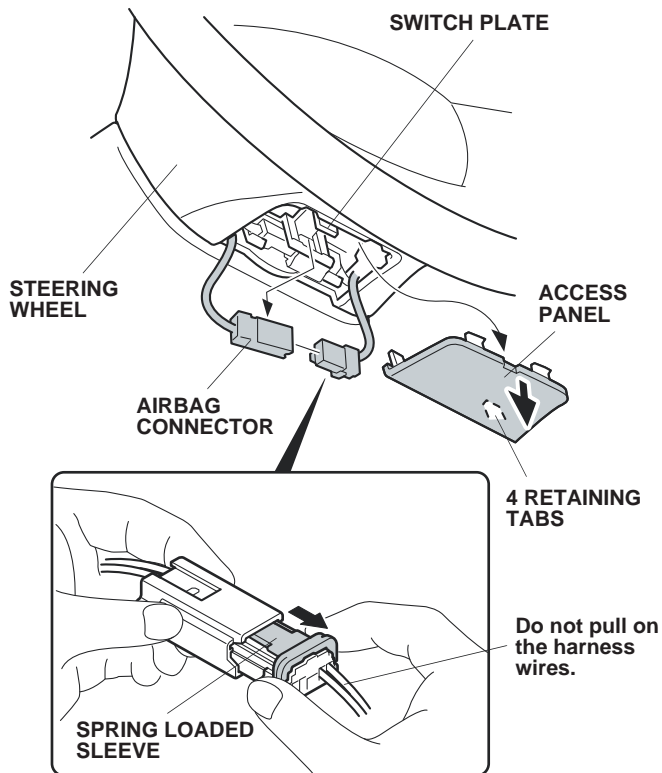

6. Remove and discard the two TORX bolts that secure the airbag, and remove the airbag. Carefully set the airbag in a secure location with the pad facing up. Do not drop or bump the airbag.

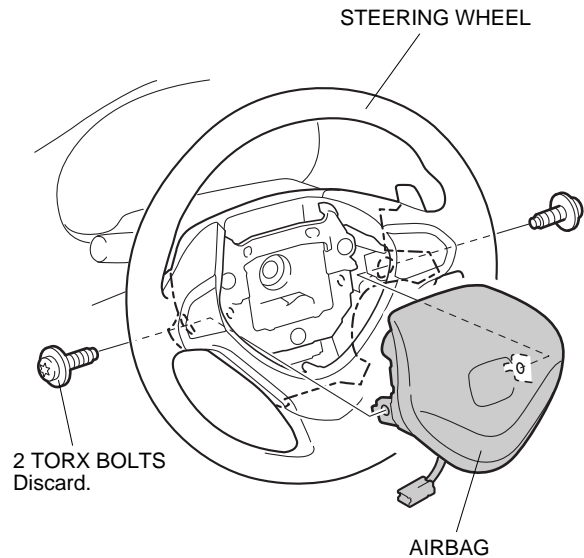

4. Remove the airbag connector from the switch plate.
5. Unplug the airbag connector. Pull the spring-loaded sleeve toward the stop while holding the opposite half of the airbag connector, then pull the airbag connector halves apart. Be sure to pull on the sleeve and not on the harness wires.

7. Turn the steering wheel so the front wheels are in the straight-ahead position.
8. Disconnect the 13-pin connector from the cable reel. Remove the steering wheel bolt. Using a steering wheel puller, remove the steering wheel. Do not thread the steering wheel puller bolts in more than 10 mm. Be careful not to rotate the steering wheel during removal.

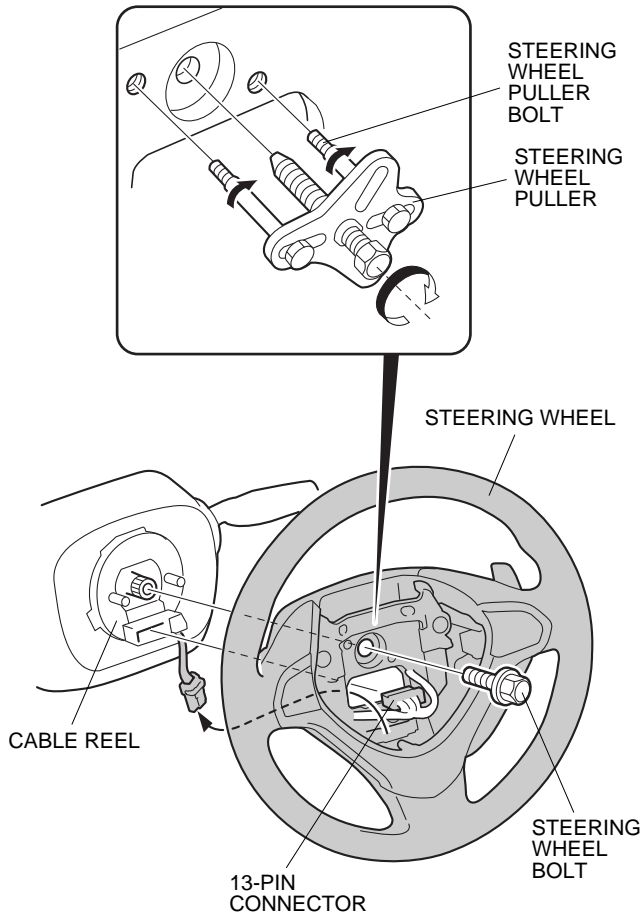

9. Remove the right switch cover from the steering wheel (four retaining tabs). If equipped, remove the left switch cover (four retaining tabs).

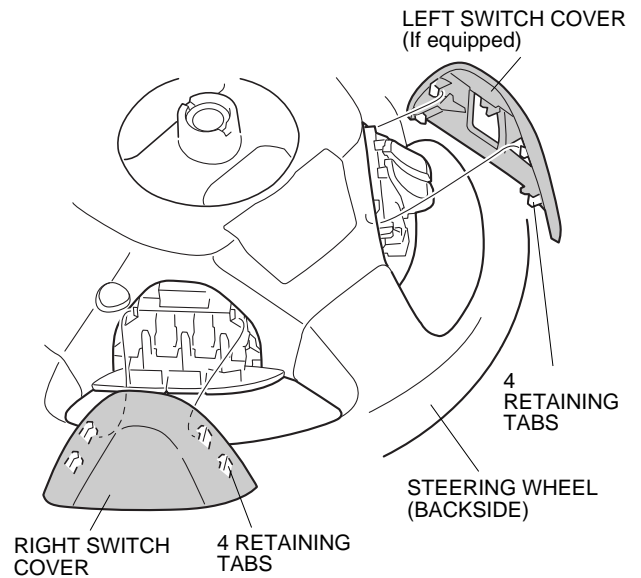

10. Remove the screw from right switch A. If equipped, remove the screw from left switch A.

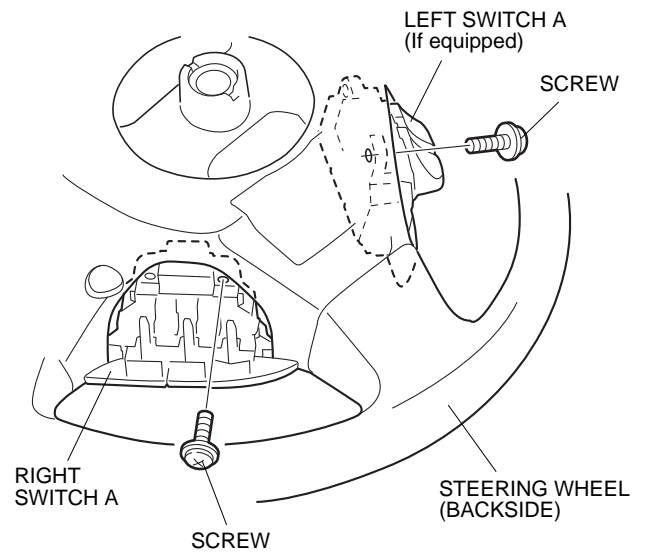

11. Remove the steering wheel trim:
- Remove the two screws, and release the steering wheel trim (three pins, two retaining tabs, and one hook).

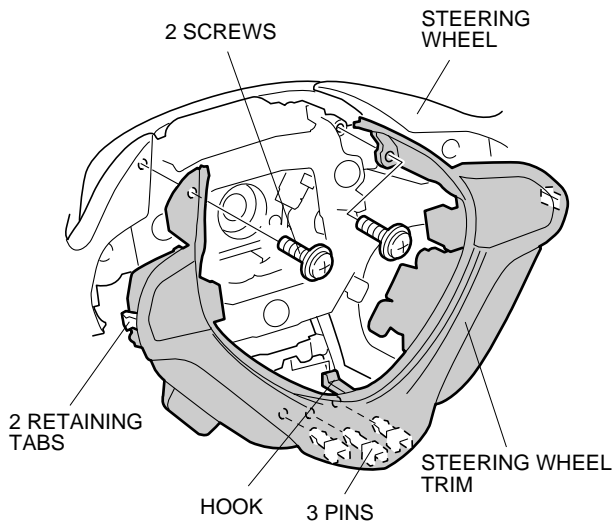

- Disconnect the four connectors and remove the steering wheel trim from the steering wheel.

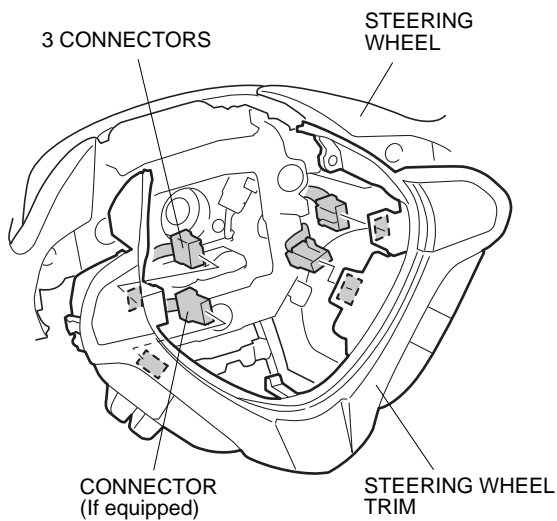

12. Remove the steering wheel cover from the steering wheel (two screws and two retaining tabs).

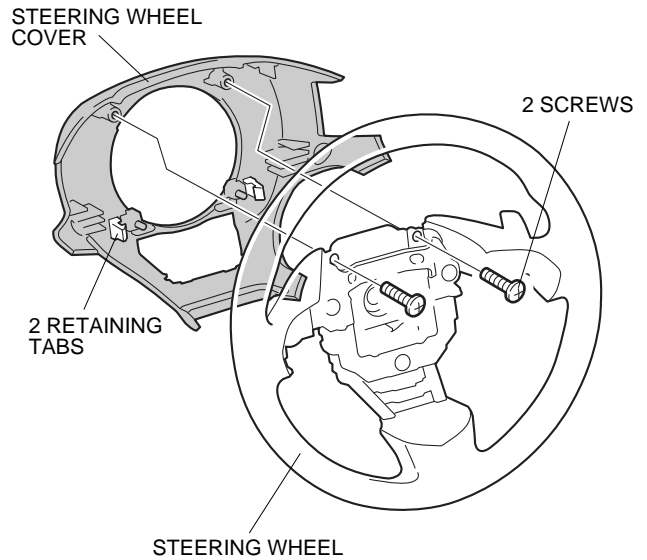

13. Unplug the horn connector.

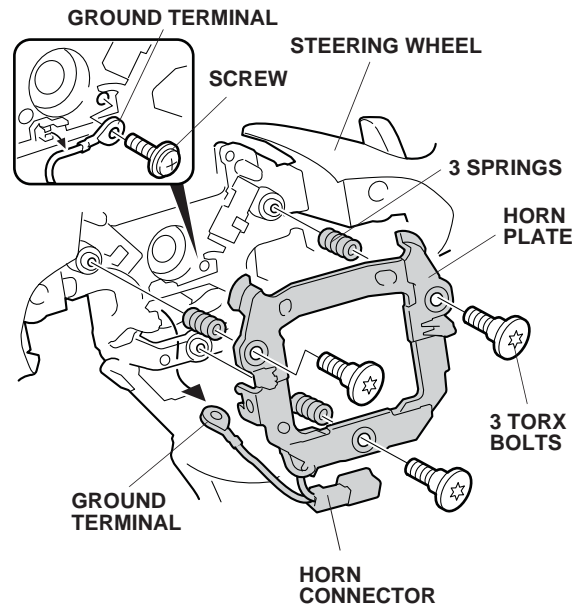

14. Remove the horn plate from the steering wheel (one screw and three TORX bolts).

15. Remove the right and left switch brackets from the steering wheel (one screw for each bracket).

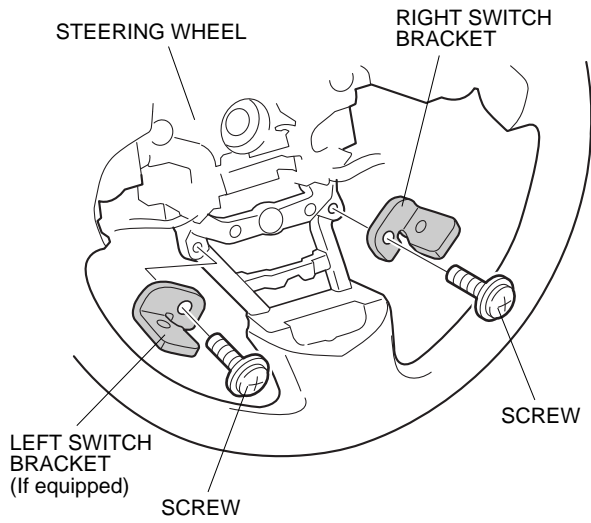

16. If equipped with paddle shifters, remove the right and left paddle switches from the steering wheel (one screw for each bracket).

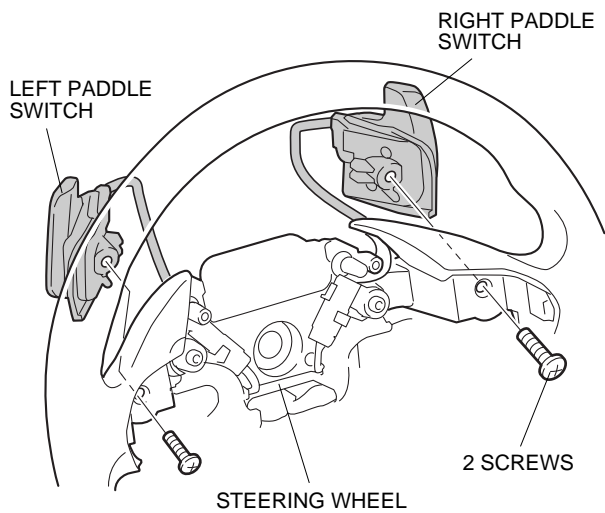

17. Remove the damper (two screws), then remove the cable guide from the steering wheel.

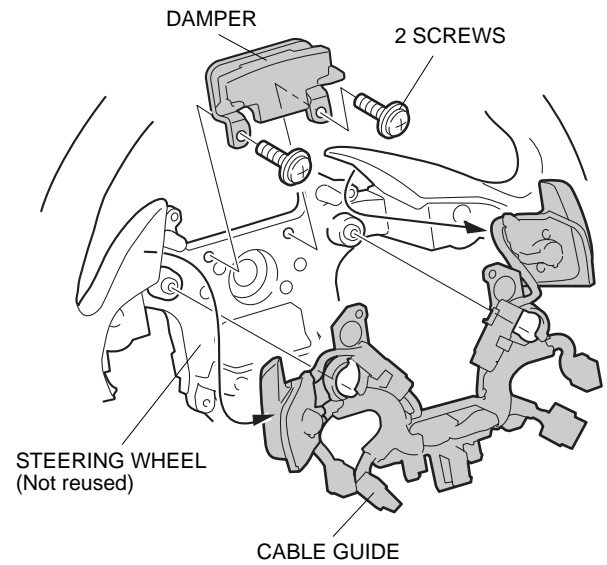

18. Install the cable guide and the damper to the new steering wheel using the two screws.

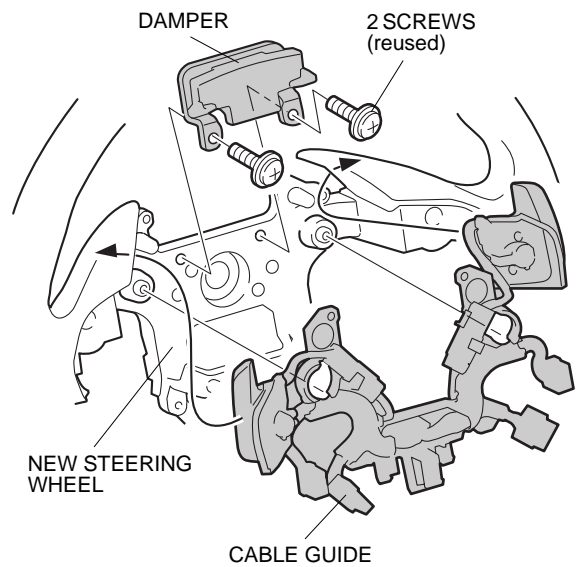

19. If equipped, install the right and left paddle switches on the new steering wheel using the two screws.

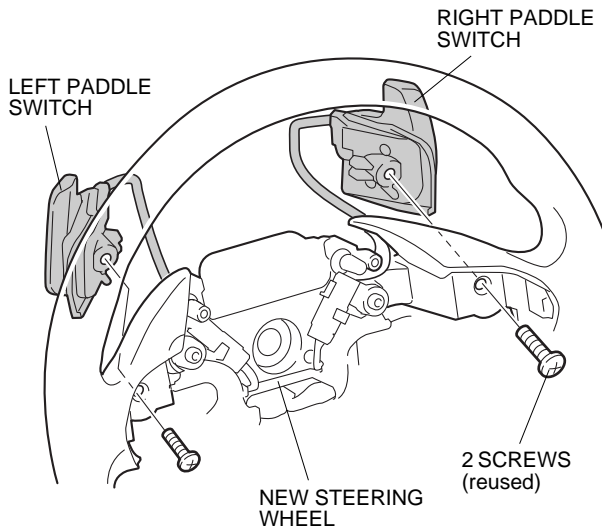

20. Install the right and left switch brackets on the new steering wheel using the two screws.

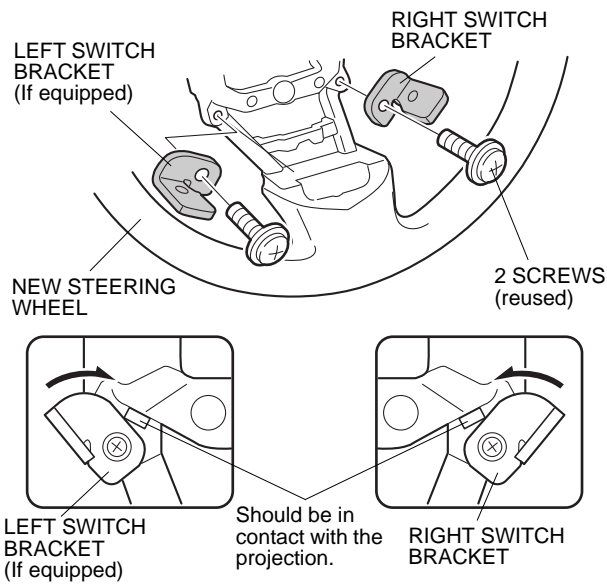

21. Install the horn plate to the new steering wheel using the one screw and three TORX bolts.

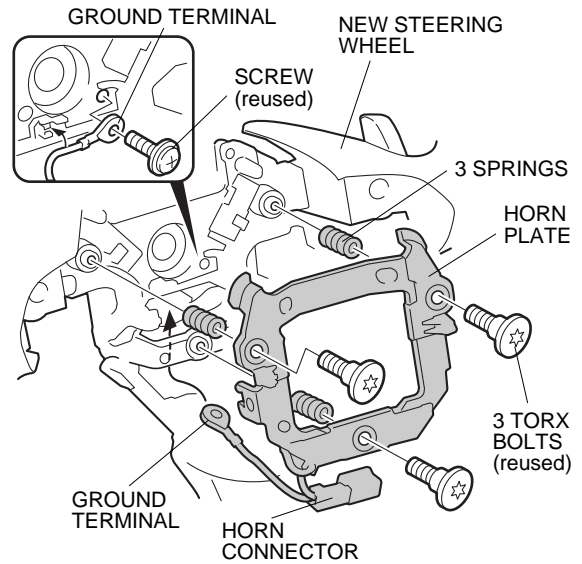

22. Reconnect the horn connector.
23. Install the steering wheel cover on the new steering wheel using the two screws.

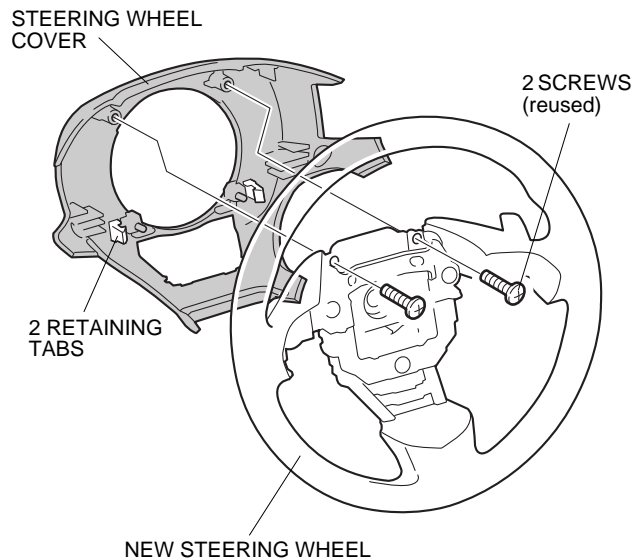

24. Reconnect the four steering wheel connectors into the steering wheel trim.

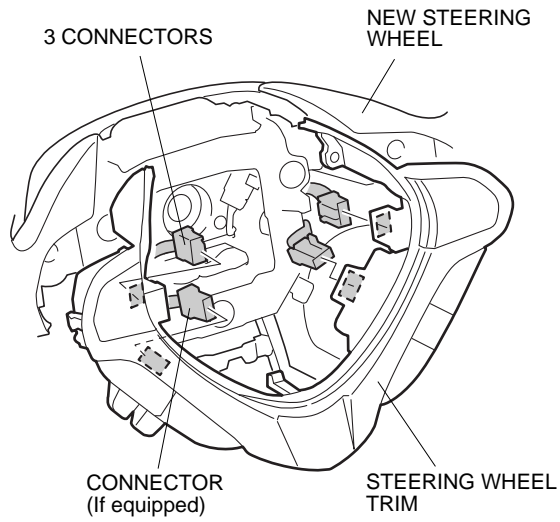

25. Install the steering wheel trim on the new steering wheel using the two screws.

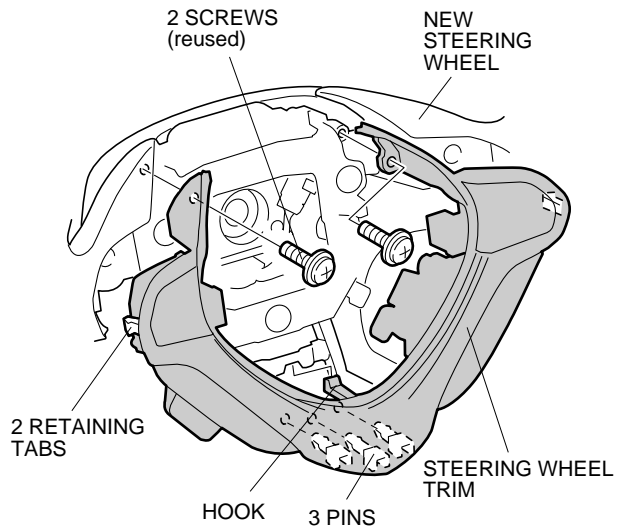

26. Install right switch A and left switch A (if equipped) using the screws you removed earlier.

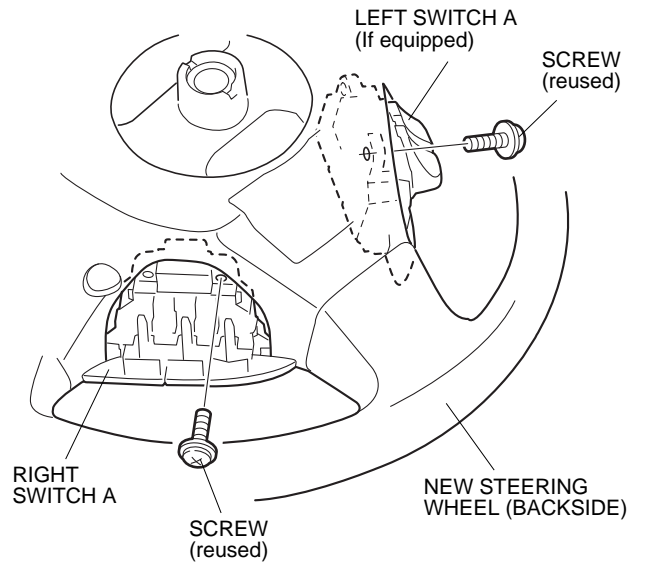

27. Install the switch covers.

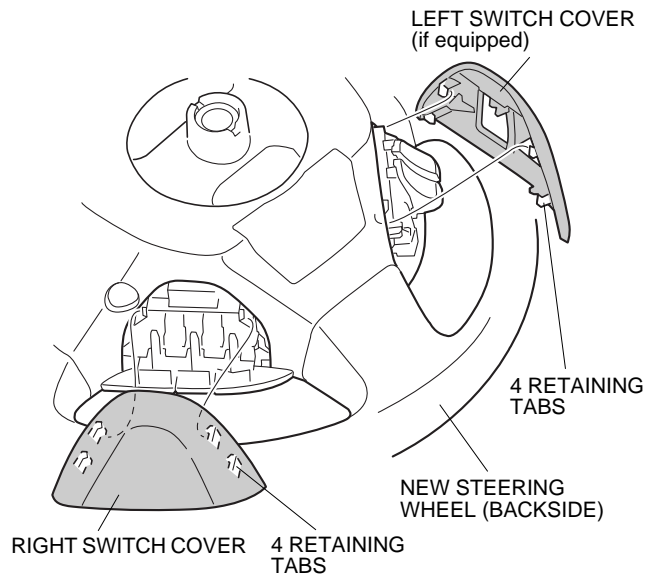

If the cable reel was moved, continue with step 28; if it was not moved, go to step 29.

28. Align the cable reel:
- Rotate the cable reel clockwise all the way until it stops.
 - Turn the cable reel counterclockwise about three complete turns until the arrow on the cable reel points up.
29. Install the steering wheel on the steering shaft in the straight-ahead position:
- Route the wire harness through the opening in the steering wheel.
 - Align the two tabs on the cancelling sleeve with the two cutouts in the steering wheel as shown.
 - Check that the wire harness is not pinched.

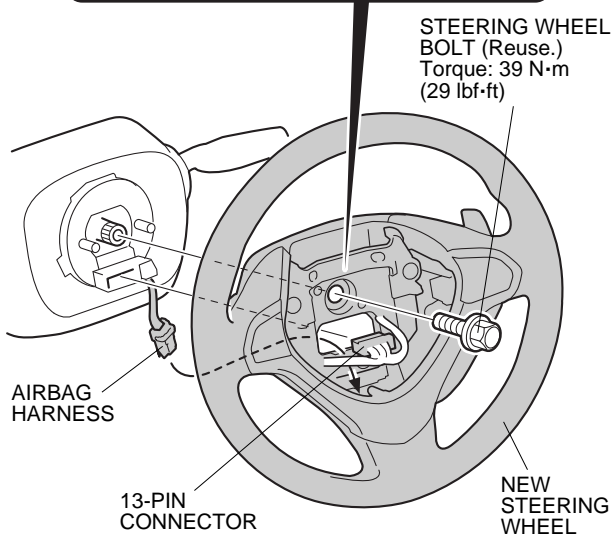
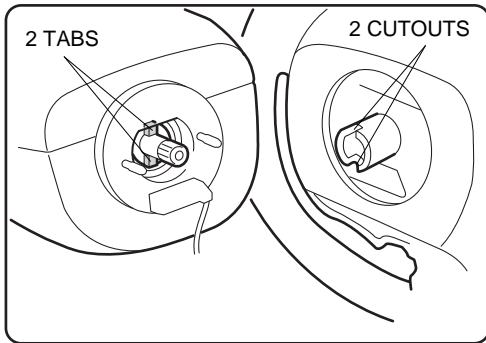

30. Install the steering wheel bolt. Torque the steering wheel bolt to 39 N·m (29 lb-ft).
31. Reconnect the 13-pin connector.

32. Route the airbag harness down through the steering wheel. Position the airbag on the steering wheel, and check that the wire harness is not pinched. Install the two new TORX bolts. Torque the TORX bolts to 10 N·m (7.2 lb-ft)

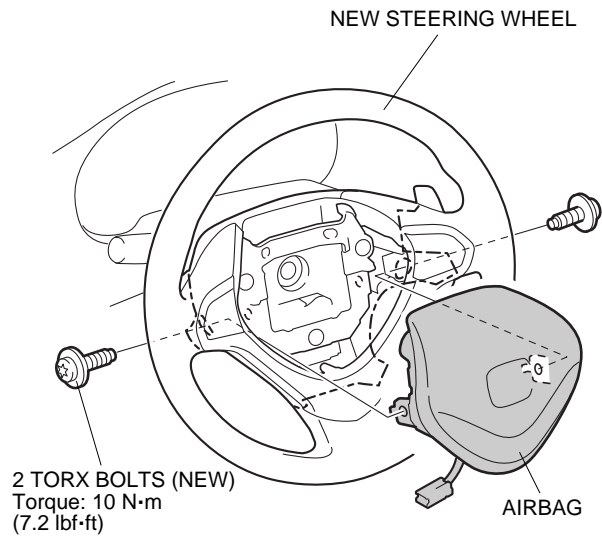

33. Plug in the airbag connectors:

- Hold the pawl-side of the airbag connector, and press on the back of the sleeve-side of the airbag connector in the direction shown.
- Do not touch the sleeve, the sleeve is pushed back by the pawl when the two airbag connectors mate.
- Reattach the airbag connector and the horn connectors to the switch plate.
- Reinstall the access panel.

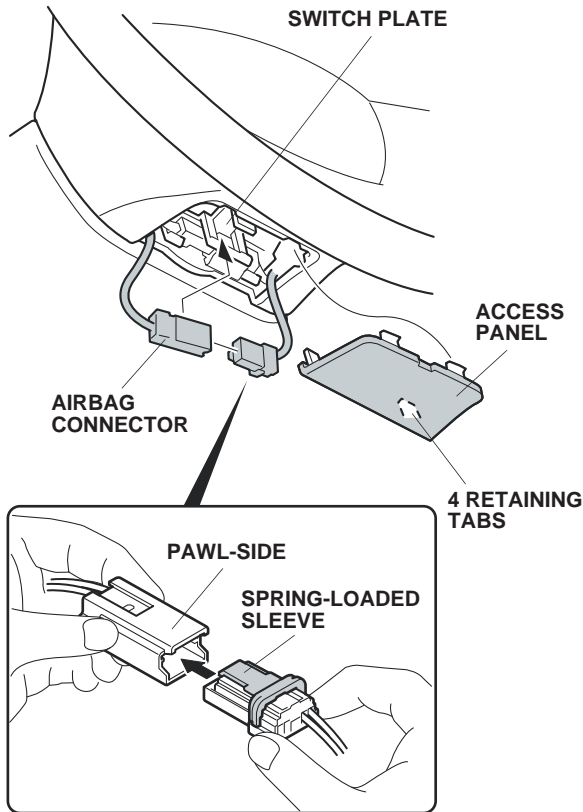

34. Reconnect the negative cable to the battery.

35. Make sure the steering wheel is in the straight-ahead position with the front wheels. If the spoke angle of the steering wheel is not in the straight-ahead position with the front wheels, straighten the wheel and apply an adhesive steering wheel offset gauge sticker (T/N 07AAJ-001A300) to the steering wheel and steering wheel column cover to measure the number of millimeters the steering wheel is off center.

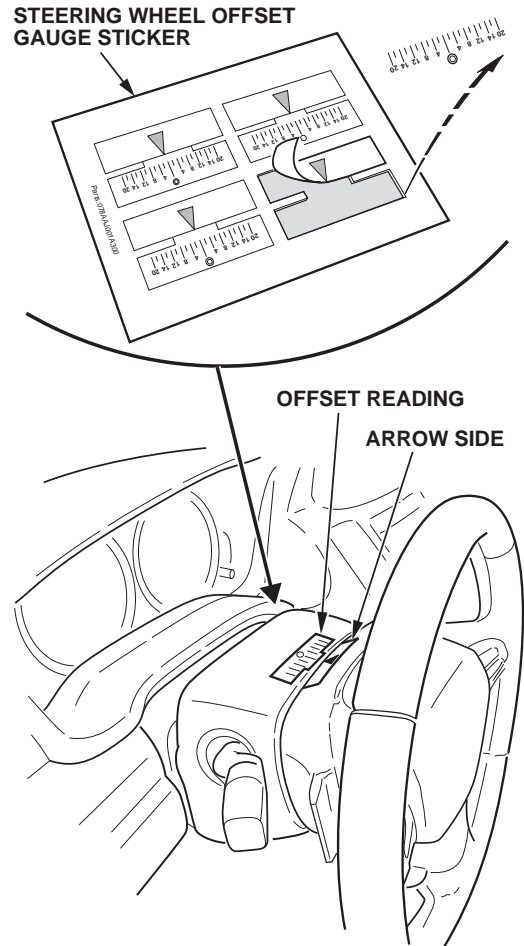

36. Test-drive the vehicle and record how many millimeters the steering wheel is off-center. Put the vehicle on a lift to adjust the tie rods using the measurements recorded during the test-drive.
 - If the wheels are pointed to the right, shorten the driver's side tie-rod, and lengthen the passenger's side.
 - If the wheels are pointed to the left, shorten the passenger's side tie-rod, and lengthen the driver's side.
 - Each 360° turn of the tie-rod equals about 8 mm of steering wheel adjustment. For example, a steering wheel is off-center by 4 mm, with the front wheels pointed right (when the steering wheel is centered). To correct the off-center, shorten the driver's side tie-rod by a half-turn, and lengthen the passenger's side tie-rod by a half-turn.
37. Make sure that the horn works.
38. Turn the ignition key on, and verify that the SRS warning light comes on and stays on for 6 seconds. Turn the key off to make sure the SRS warning light goes off.
39. Enter the anti-theft code for the audio and the navigation system (if equipped), then enter the audio presets.
40. Reset the clock (without navigation).