



INSTALLATION INSTRUCTIONS

Accessory
ENGINE BLOCK HEATER
P/N 08T44-SNA-101

Application
2014 TSX
(V6)

Publications No.
BII 50188
Issue Date
SEPT 2013

PARTS LIST

Engine block heater

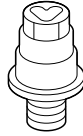

Aluminum washer



Heater harness

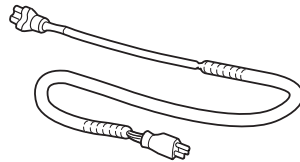

Protective cap

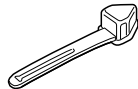

12 Black wire ties
(5 Not used)

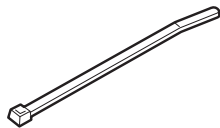

7 Wire ties with clips
(5 Not used)

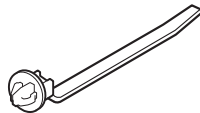

5 White wire ties
(4 Not used)

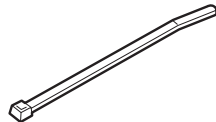

TOOLS AND SUPPLIES REQUIRED

Phillips screwdriver

Ratchet

10 mm, 19 mm, and 24 mm Sockets

Torque wrench

Diagonal cutters

Heavy gloves

Drain pan

Tape measure

White marker

Honda All-Season Antifreeze/Coolant Type 2

Fender cover

Blanket

Plastic Trim Tool (SILTRIMTL10)

(Available through the Honda Tool and Equipment program. On the iN, click on: Service/Service Bay/Tool and Equipment Program, then enter the number under "Search." Or call 888-424-6857.)

INSTALLATION

NOTE:

- Always use Honda All-Season Antifreeze/Coolant Type 2. Using a non-Honda coolant can result in corrosion, causing the cooling system to malfunction or fail.
- To avoid burning out the element, do not operate the engine block heater until it is installed in the vehicle and you have added coolant.

Client Information: The information in this installation instruction is intended for use only by skilled technicians who have the proper tools, equipment, and training to correctly and safely add equipment to your vehicle. These procedures should not be attempted by “do-it-yourselfers.”

1. Make sure you have the anti-theft codes for the audio unit and navigation system (if equipped), then write down the radio station presets.
2. Allow the engine and all cooling system components to cool down.
3. Remove the left engine room cover (one clip, three pins, and one tab).

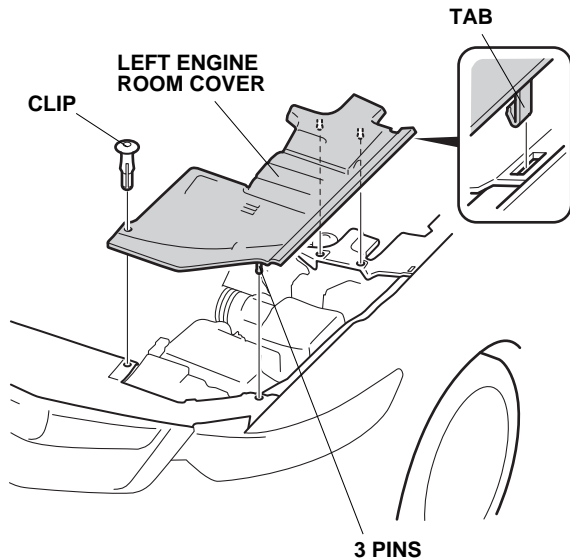

4. Raise the right engine room cover (one clip and one pin).

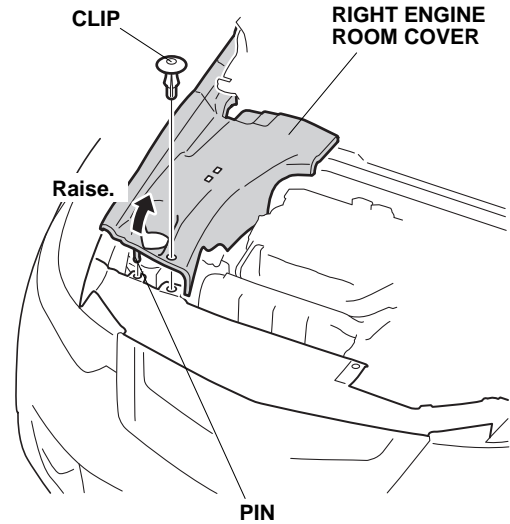

5. Remove the radiator cover (six clips).

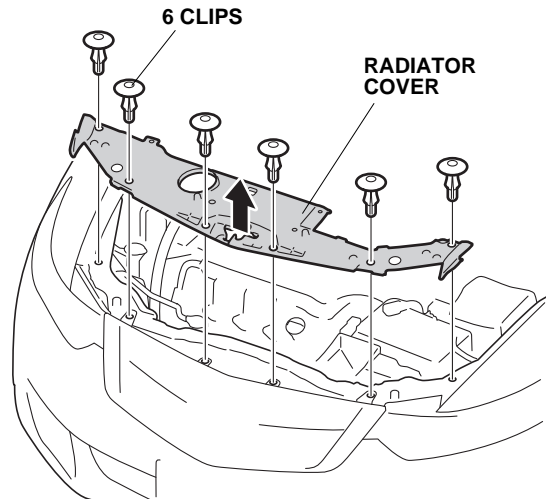

- Remove the intake air cover (two clips and one hook).

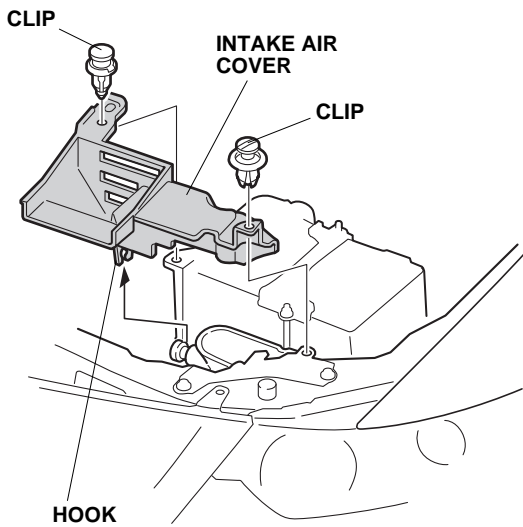

- Disconnect the negative (-) cable from the battery, open the positive cable cover, and disconnect the positive (+) cable from the battery. Unfasten the two battery holder nuts and remove the battery holder.

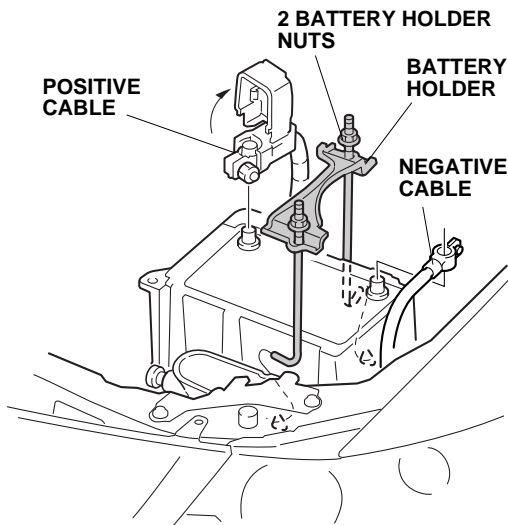

- Remove the battery cover, battery, and battery box.

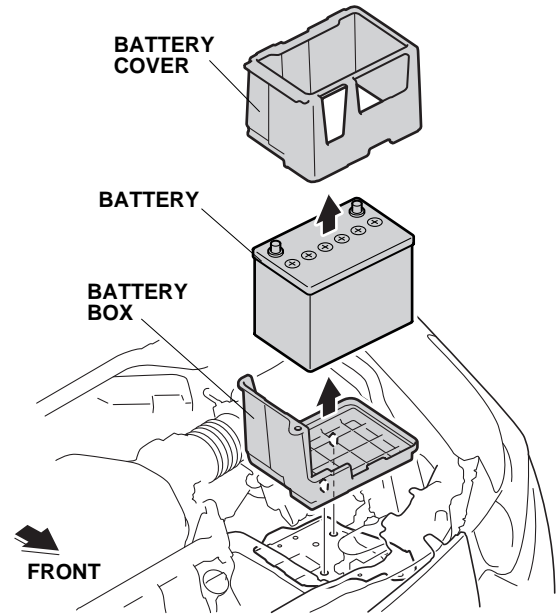

- Place a clean drain pan under the radiator drain plug, then remove the drain plug from the bottom of the radiator to drain the coolant. Remove the cover and radiator cap to increase the flow.

NOTICE: Radiator coolant will damage paint. Quickly rinse any spilled coolant from painted surfaces.

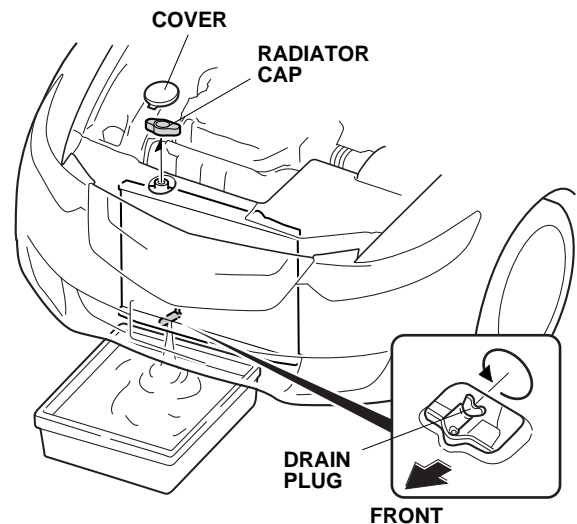

10. Remove the two self-tapping screws, ten short clips, and two long clips from the front bumper.

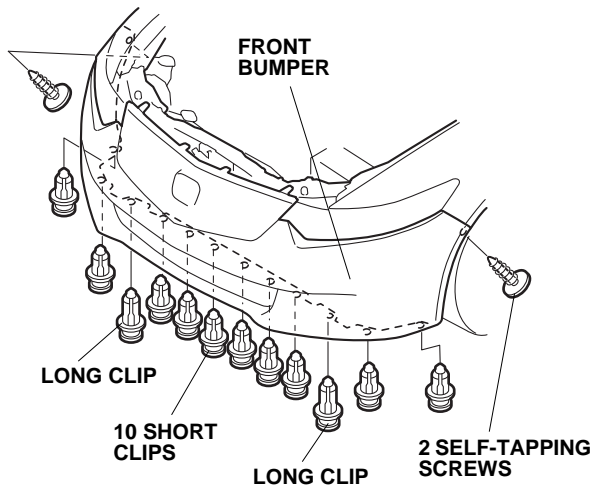

11. Release the eight tabs, and pull the front bumper toward you.

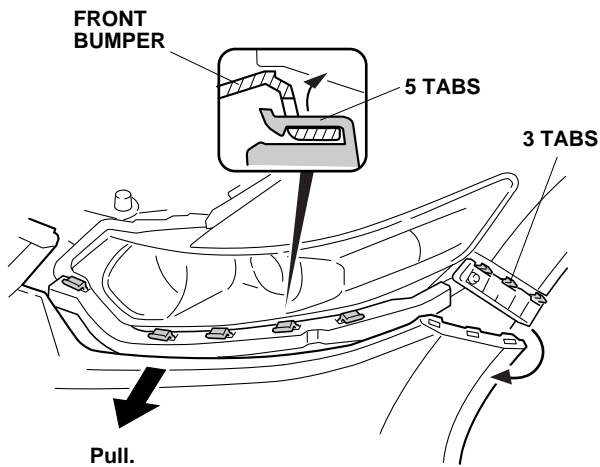

12. Repeat step 11 on the other side of the front bumper.

13. Remove the front bumper (unplug the two fog light connectors).
- Have an assistant help you when removing the front bumper.
 - Place the front bumper on a blanket to prevent damage.

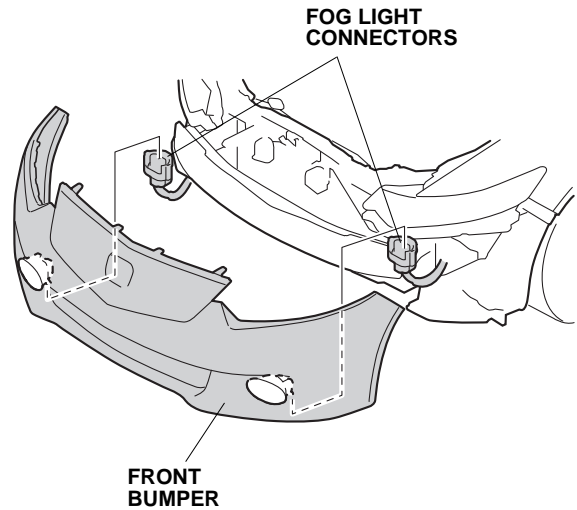

14. Get the heater harness. Using a tape measure, install two wire ties with clips to the heater harness at the measurements shown.

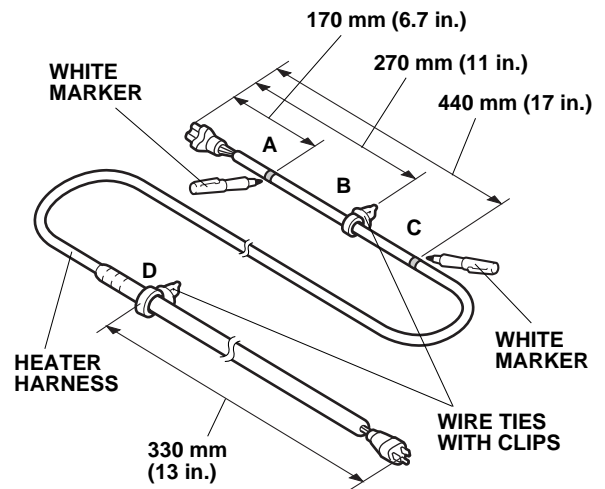

15. Using a white marker, mark the heater harness at the measurements shown.

16. Locate and remove the engine block drain bolt and washer. Coolant remaining in the engine jackets flows out of the bolt hole when the bolt is removed. (Retain the bolt and washer in case the block heater is removed.)

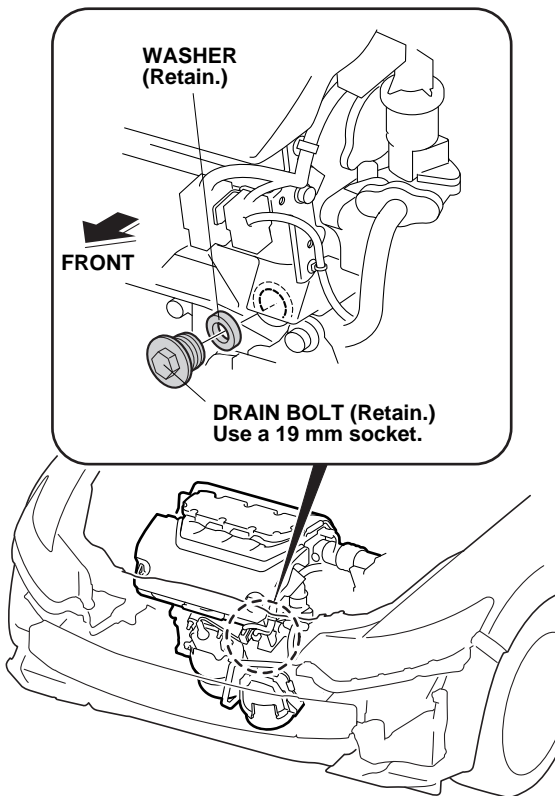

17. Install the engine block heater with aluminum washer into the engine block using a 24 mm socket and a torque wrench. Torque the engine block heater to 60 N·m (44 lbf·ft).

NOTE: Using an extension longer than 4" will give an incorrect torque reading.

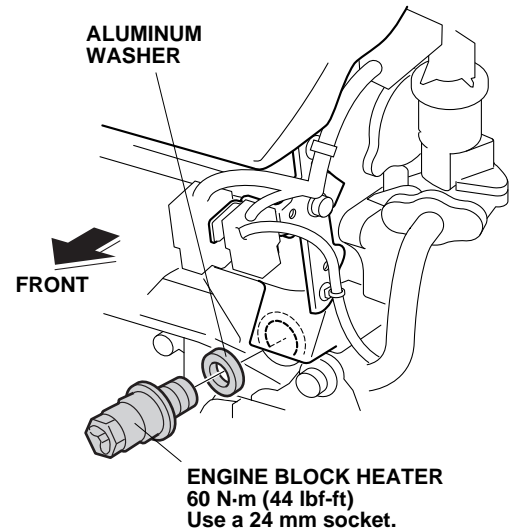

18. Plug the connector end of the heater harness into the engine block heater.

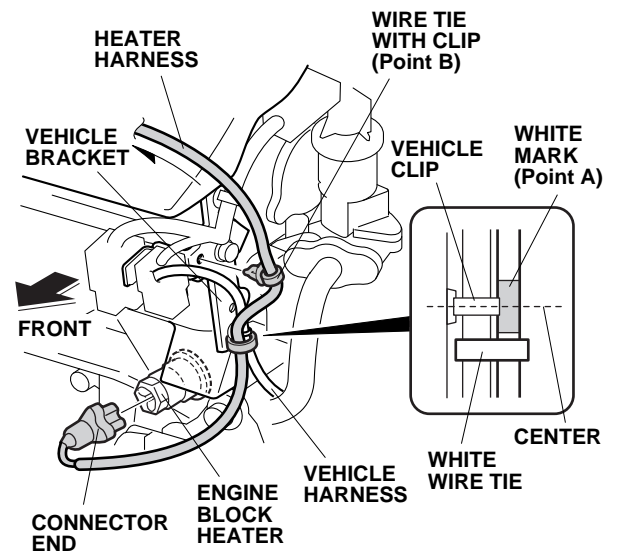

19. Route the heater harness as shown and secure the heater harness to the vehicle harness at point A with one white wire tie. Secure the wire tie with clip (point B) to the vehicle bracket.

20. Route the heater harness as shown and secure it to the fan shroud rib with four black wire ties.

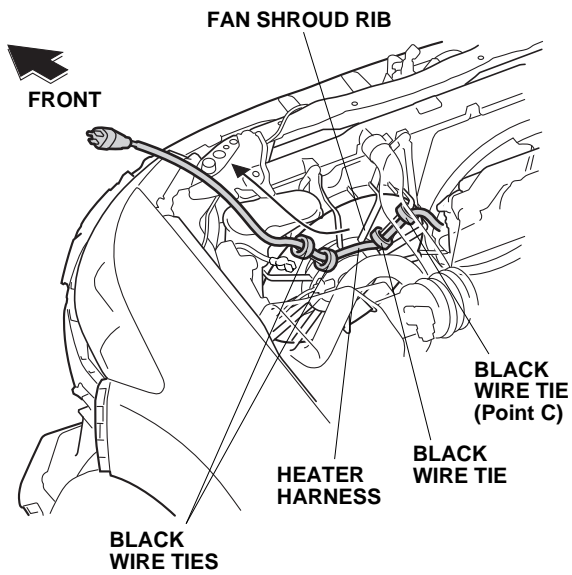

21. Route the heater harness through the engine compartment as shown.

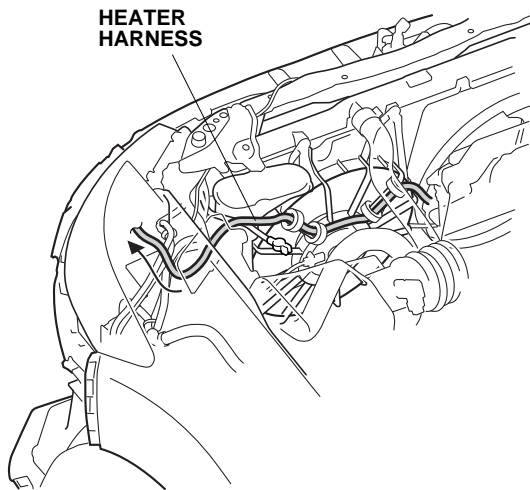

22. Route the heater harness as shown and secure the wire tie with clip (point D) to the vehicle frame.

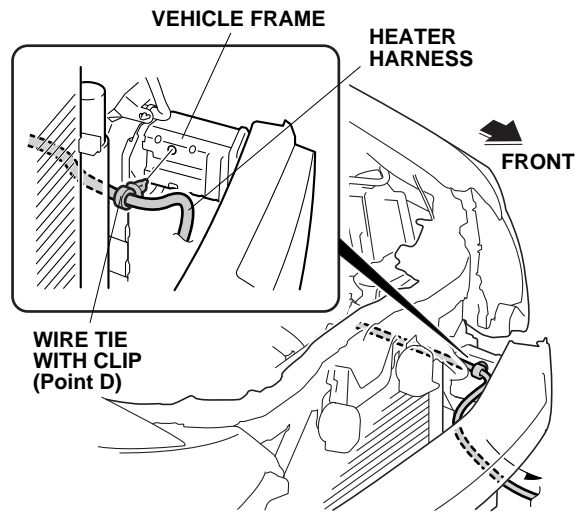

23. Bundle up the excess heater harness, and secure it to the vehicle harness with two black wire ties.

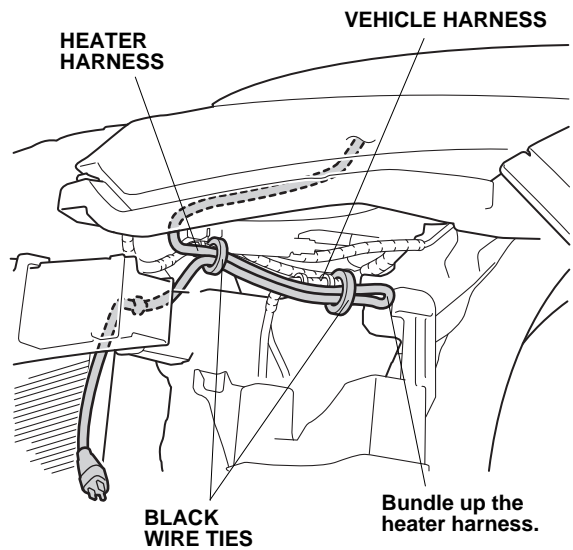

If the vehicle you are working on is equipped with an Aero Bumper, continue with step 24; otherwise, go to step 28.

24. Bring the front bumper close to the vehicle. Route the heater harness through the front bumper grille as shown, and install the front bumper in the original position.

- Have an assistant help you when installing the front bumper.
- Install the clips securely so that they are not raised.

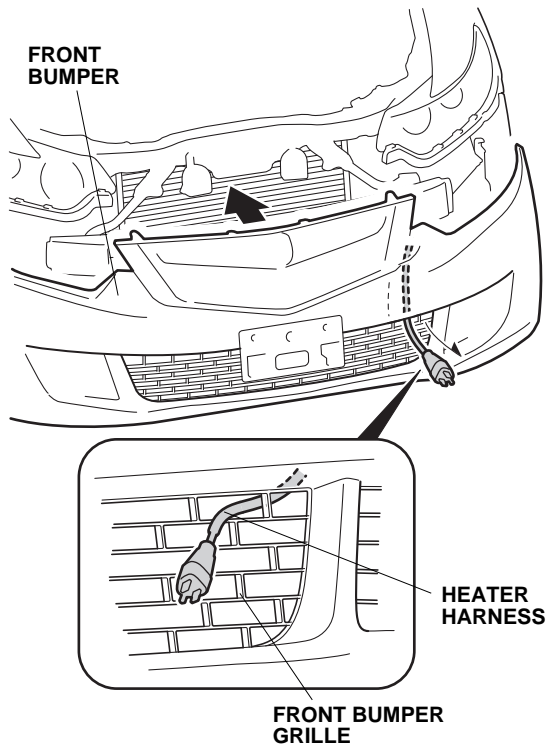

25. Attach the protective cap to the front bumper grille, and plug the connector on the heater harness into the protective cap.

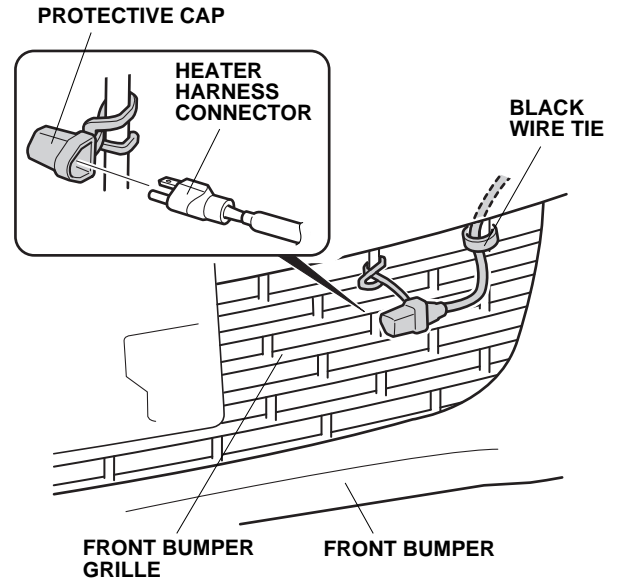

26. Secure the heater harness to the front bumper grille with one black wire tie.

27. Go to step 31.

28. Bring the front bumper close to the vehicle. Route the heater harness through the front bumper grille as shown, and install the front bumper in the original position.

- Have an assistant help you when installing the front bumper.
- Install the clips securely so that they are not raised.

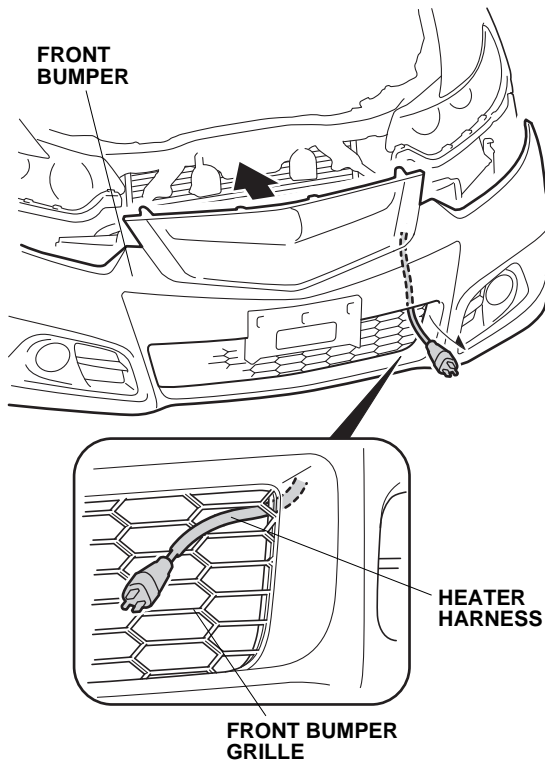

29. Attach the protective cap to the front bumper grille, and plug the connector on the heater harness into the protective cap.

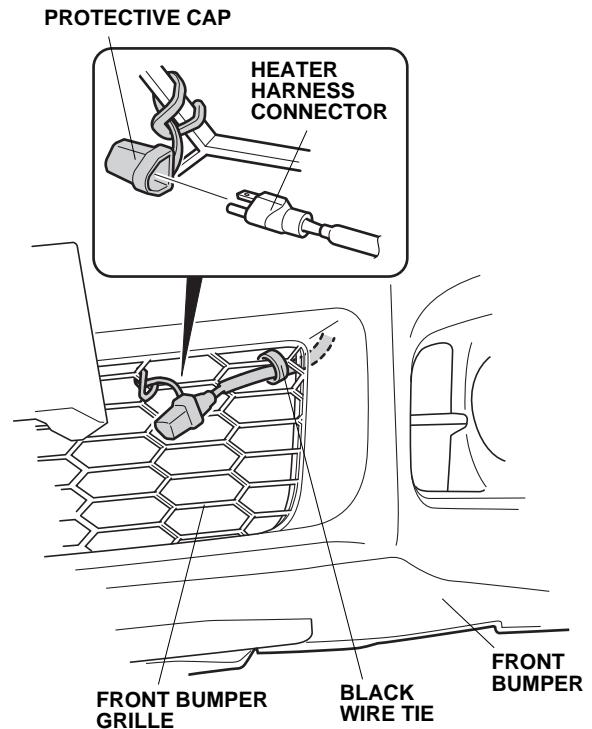

30. Secure the heater harness to the front bumper grille with one black wire tie.
31. Check that the heater harness is routed properly and all connectors are plugged in.
32. Reinstall all removed parts except for the radiator cap.
33. Fill the system with the recommended coolant. Follow the instructions described in the service manual to fill and bleed the cooling system.
34. Check the coolant reservoir for correct level and check the cooling system for signs of leakage. Repair as necessary.
35. Put the drain bolt and washer (removed in step 16) in the glove box.
36. Enter the anti-theft codes for the audio unit and the navigation system (if equipped), and reset the radio station presets.
37. Reset the clock on the models without a navigation system.