



INSTALLATION INSTRUCTIONS

Accessory
ENGINE BLOCK HEATER
P/N 08T44-SNA-101

Application
2014 TL

Publications No.
BII 50160
Issue Date
AUG 2013

PARTS LIST

Engine block heater

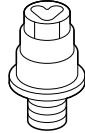

Aluminum washer



Heater harness

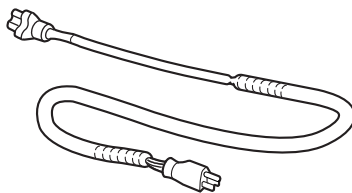

Protective cap

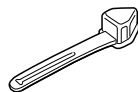

12 Black wire ties
(6 Not used)

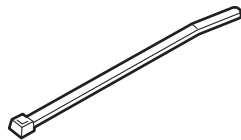

(6 Not used)
7 Wire ties with clip

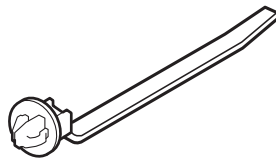

5 White wire ties
(2 Not used)

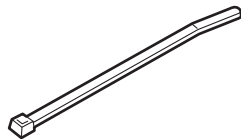

TOOLS AND SUPPLIES REQUIRED

Phillips screwdriver

Flat-tip screwdriver

Ratchet

10 mm, 19 mm, and 24 mm Sockets

Long extension

Torque wrench

Diagonal cutters

Heavy gloves

Drain pan

Tape measure

White marker

Coolant (Acura Long Life Antifreeze/Coolant Type 2)

Fender cover

Blanket

Plastic Trim Tool (T/N SILTRIMTL10)

Illustration of the Engine Block Heater in the Vehicle

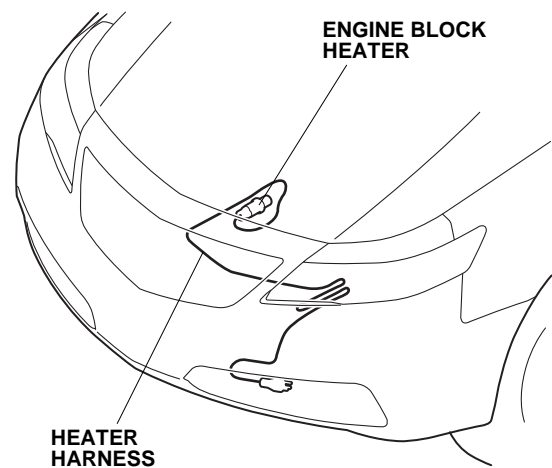

INSTALLATION

Client Information: The information in this installation instruction is intended for use only by skilled technicians who have the proper tools, equipment, and training to correctly and safely add equipment to your vehicle. These procedures should not be attempted by “do-it-yourselfers.”

NOTE:

- Always use Acura Long Life Antifreeze/Coolant Type 2. Using a non-Acura coolant can result in corrosion, causing the cooling system to malfunction or fail.
 - To avoid burning out the element, do not operate the engine block heater until it is installed in the vehicle and you have added coolant.
1. Allow the engine and all cooling system components to cool down.
 2. Open the hood. Remove the front bulkhead cover (four clips and two hooks).

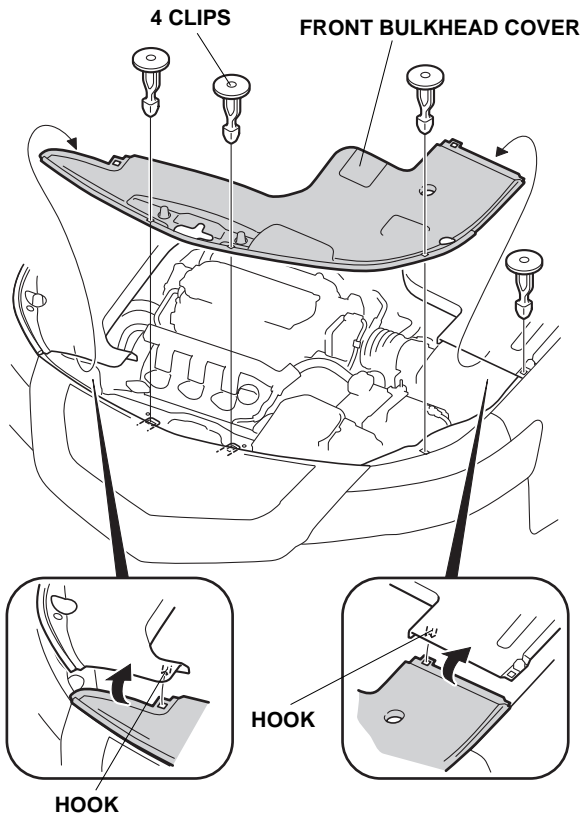

3. Place a clean drain pan under the radiator drain plug, then remove the drain plug from the bottom of the radiator to drain the coolant. Remove the radiator cap to increase the flow.

NOTICE: Radiator coolant will damage paint. Quickly rinse any spilled coolant from painted surfaces.

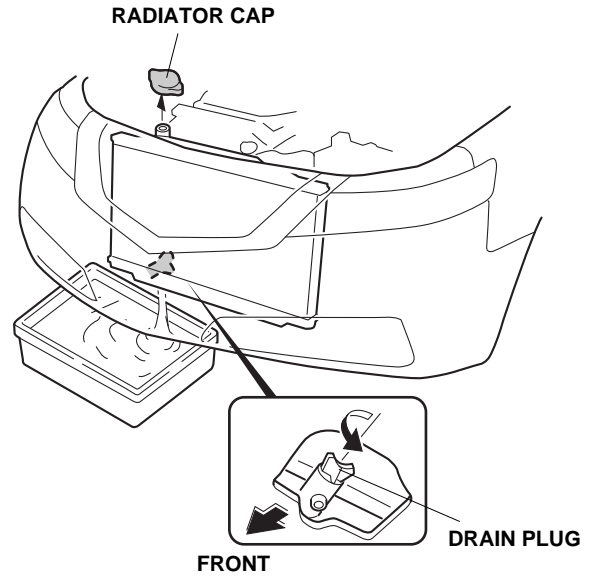

4. Remove the four clips, and raise the engine compartment right cover.

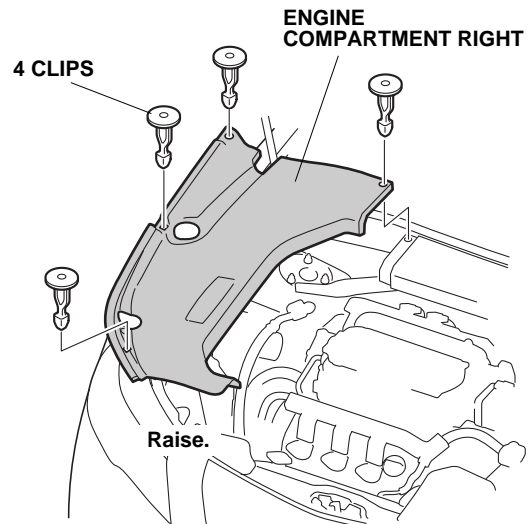

- Remove the four bolts from the front bumper.

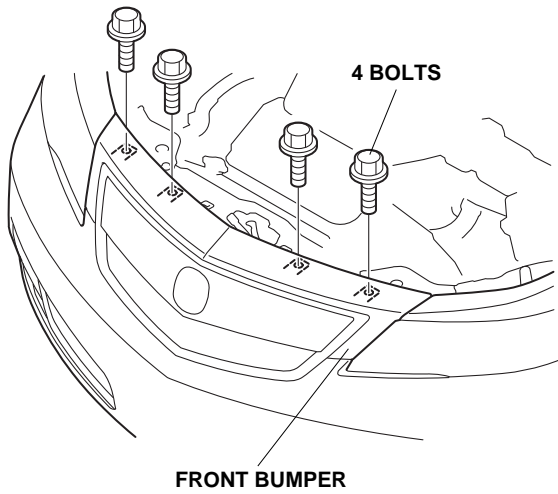

- Remove the left front air spoiler and the left strake (five bolts).

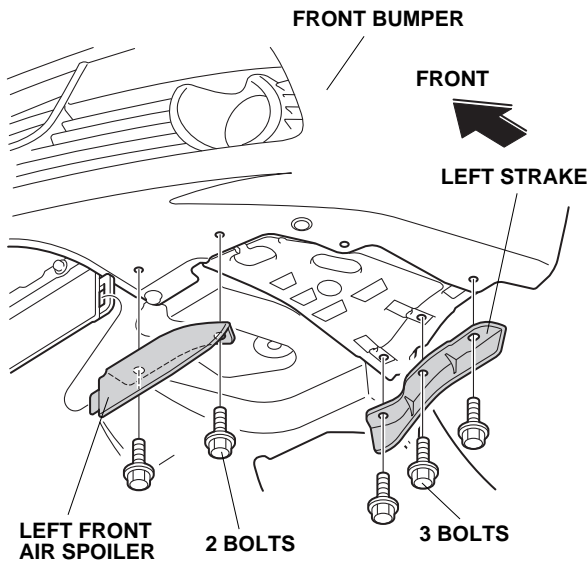

- Remove the right front air spoiler and the right strake.
- Remove the two self-tapping screws, six clips, and two bolts from the front bumper.

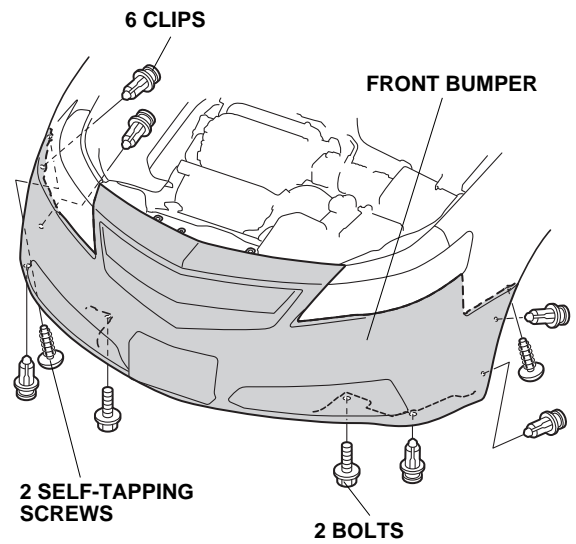

- On each side, release the 11 hooks, and gently pull the front bumper away from the body.

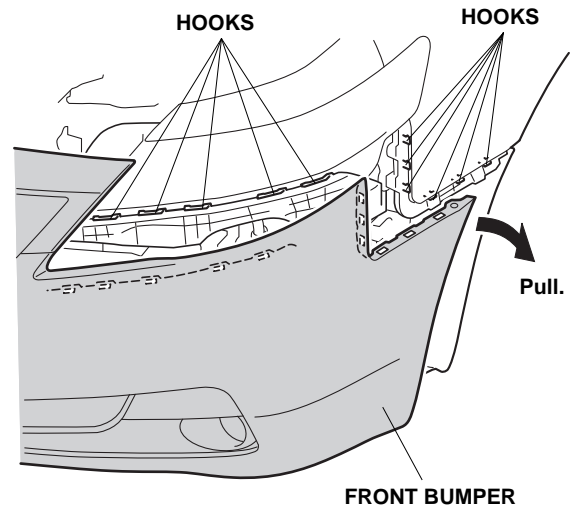

10. With the help of an assistant, remove the front bumper (unplug the five vehicle connectors). Place the front bumper on a blanket so it does not get damaged.

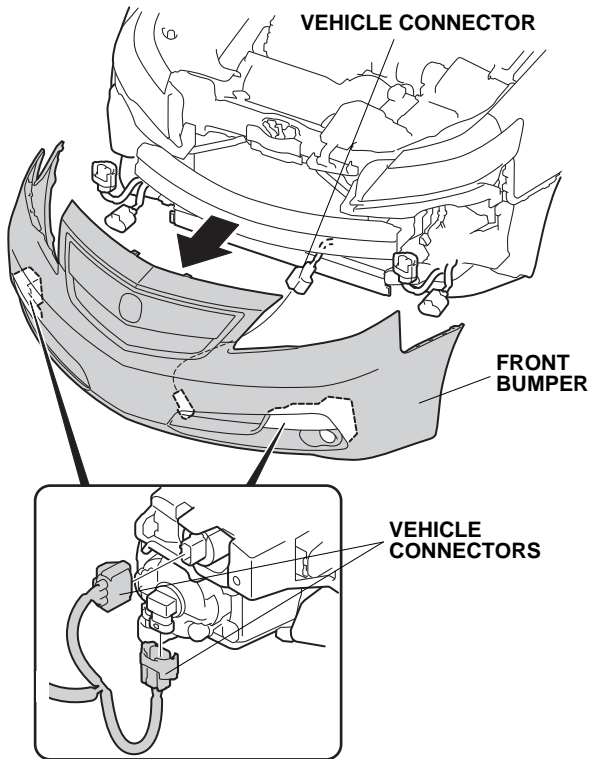

11. Unplug the vehicle connector, and remove the vehicle connector from the vehicle bracket.

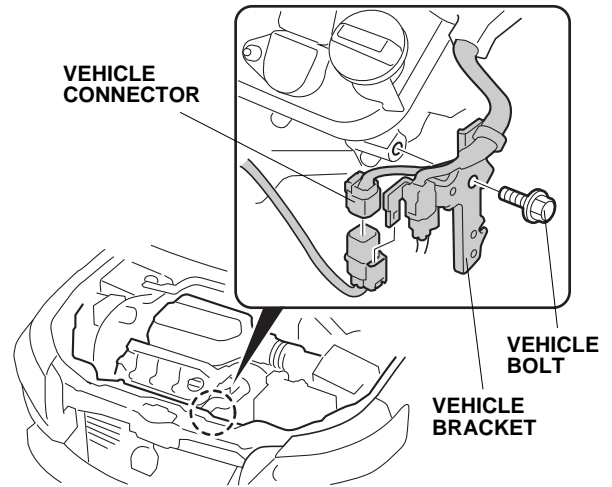

12. Remove the vehicle bolt, and release the vehicle bracket.
13. Using a 19 mm socket and a 3 inch long extension, remove the drain bolt and washer from the engine block. Remaining coolant will drain from the engine block when the bolt is removed. Retain the bolt; it will be used if the engine block heater is removed.

NOTE: Use a new washer if the drain bolt is reinstalled.

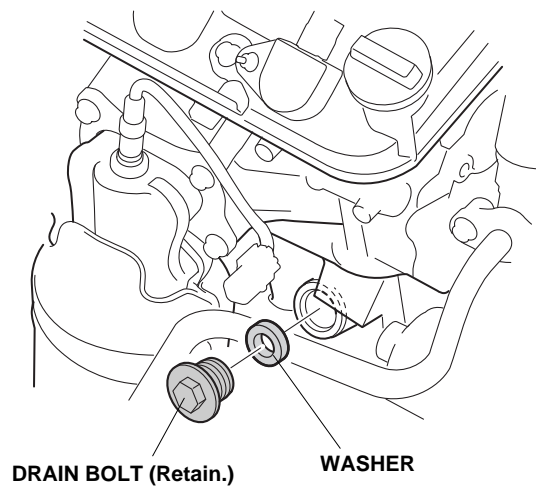

- Install the engine block heater with the aluminum washer into the drain hole using a 24 mm socket. Torque the engine block heater to 60 N·m (44 lbf·ft).

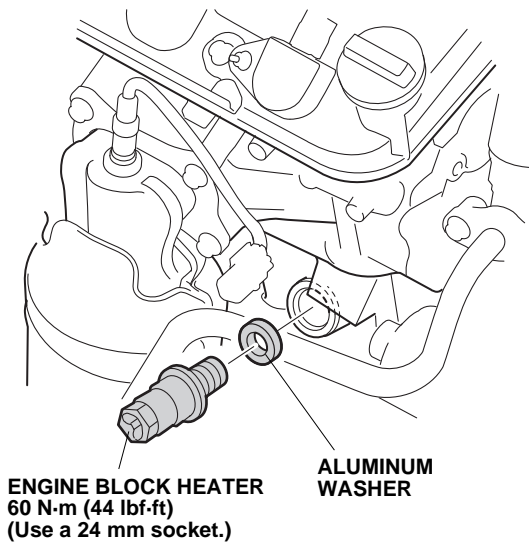

- Measure, then install a wire tie with clip to the heater harness at the measurement shown. Using a white marker, measure and mark the heater harness at the locations shown.

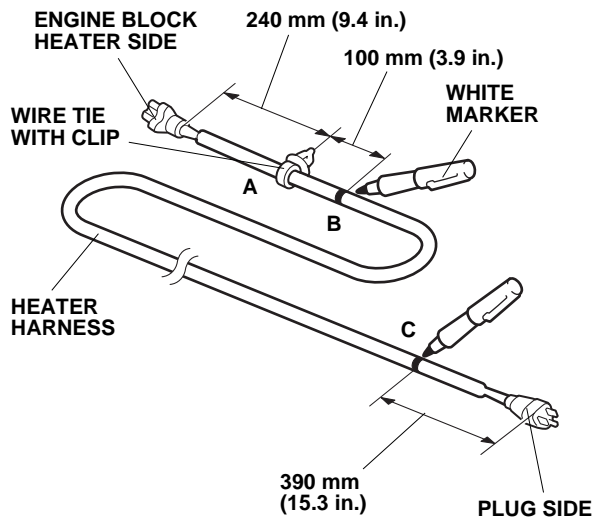

- Reinstall the vehicle bracket with the vehicle bolt removed in step 12. Reattach the vehicle connector to the vehicle bracket, and plug in the vehicle connector.

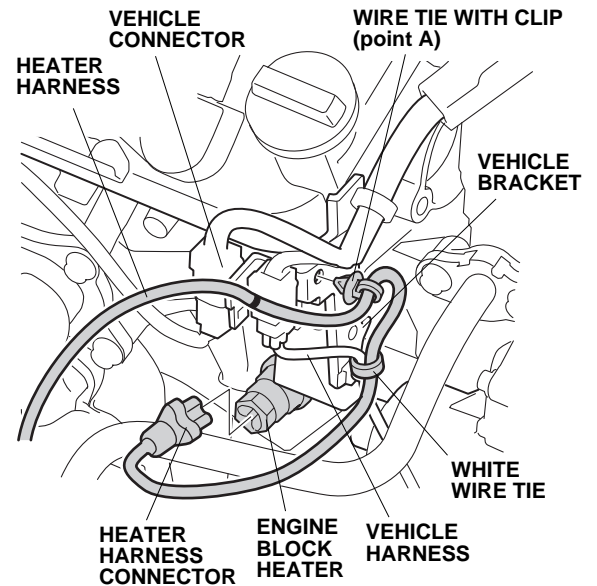

- Plug the heater harness connector into the engine block heater. Route the heater harness as shown, and secure the wire tie with clip (point A) to the vehicle bracket.
- Secure the heater harness to the vehicle harness using one white wire tie.

- Route the heater harness as shown. Align the white mark (point B) on the heater harness with the rib on the fan frame, and secure the heater harness to the rib using one white wire tie at the white mark.

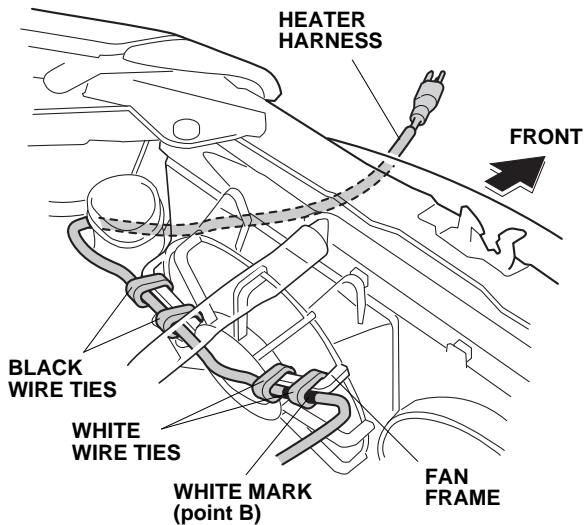

- Secure the heater harness to the ribs on the fan frame using an additional white wire tie and two black wire ties.
- Align the white mark (point C) on the heater harness with the vehicle clip, and secure the heater harness to the vehicle harness using one black wire tie.

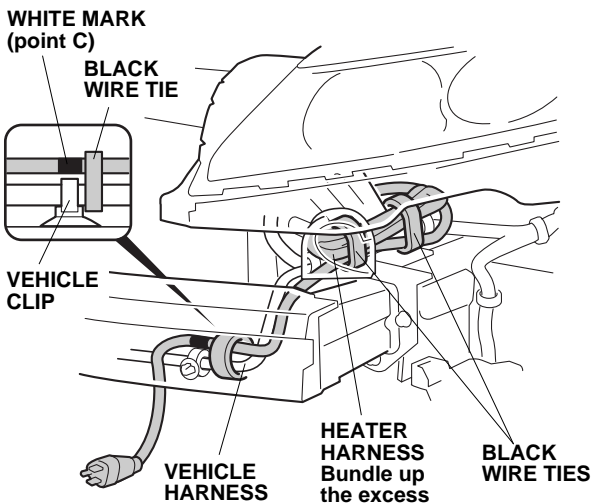

- Bundle up the excess heater harness, and secure it to the vehicle harness using two black wire ties as shown.
- With the help of an assistant, move the front bumper close to the vehicle. Route the heater harness

through the front bumper grille as shown, and reinstall the front bumper.

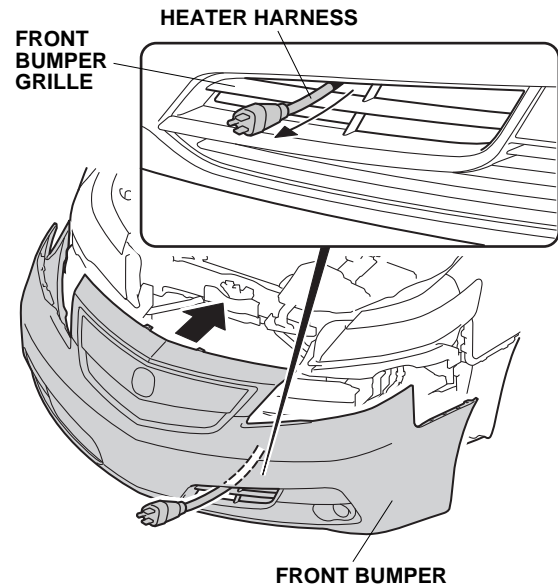

- Secure the heater harness to the front bumper grille using one black wire tie.

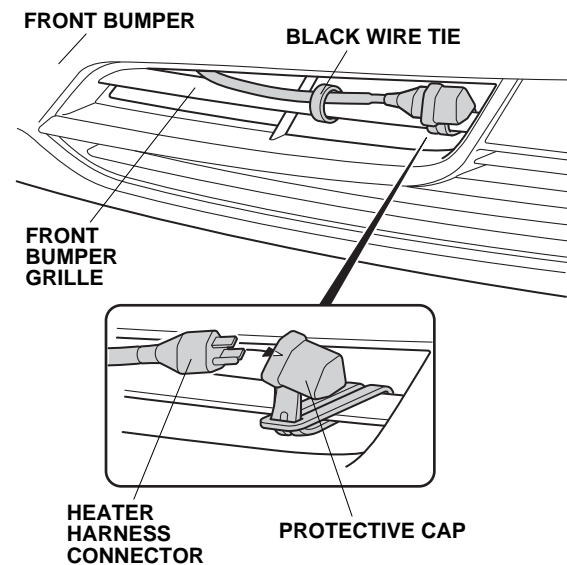

- Attach the protective cap to the front bumper grille, and plug the heater harness connector into the protective cap.
- Reinstall all removed parts except for the radiator cap and the front bulkhead cover.

27. Check that the heater harness is routed properly and all connectors are plugged in.
28. Reinstall the radiator drain plug.
29. Fill the system with the recommended coolant. Follow the instructions in the service manual to fill and bleed the cooling system.
30. Check the coolant reservoir for correct level and check the cooling system for signs of leakage. Repair as necessary.
31. Reinstall the radiator cap and the front bulkhead cover.
32. Put the drain bolt (removed in step 13) in the glove box.