

PARTS LIST

Trailer Hitch Kit P/N 08L92-SZN-200

Trailer hitch

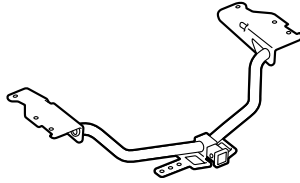

Ballmount

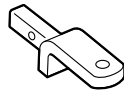

2 Spacers



Hitch pin



Hitch pin clip



6 Hex bolts, 10 x 40 mm

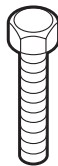

6 Spring washers



6 Plain washers



Receiver cover

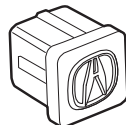

Trailer Harness Kit P/N 08L91-SZN-200

Control unit

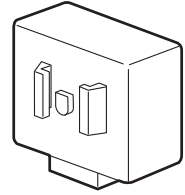

Control unit bracket

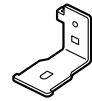

Control unit harness

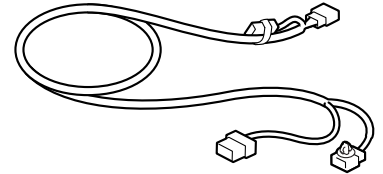

Socket harness

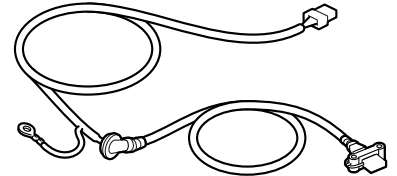

EPT sealer

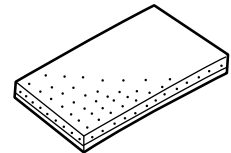

2 Flange bolts, 6 x 40 mm



Screw grommet



Self-tapping screw



6 Wire ties

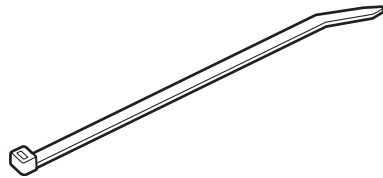

2 Fuses, 7.5A

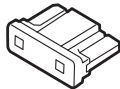

Accessory User's Information Manual

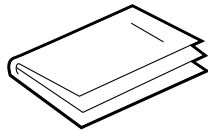

TOOLS AND SUPPLIES REQUIRED

Phillips screwdriver

Flat-tip screwdriver

Ratchet

10 mm Socket

Plastic trim tool (P/N SILTRIMTL10)

Utility knife

Scissors

Diagonal cutters

10 mm Wrench

Shop towel

Isopropyl alcohol

Illustration of the Trailer Hitch on the Vehicle

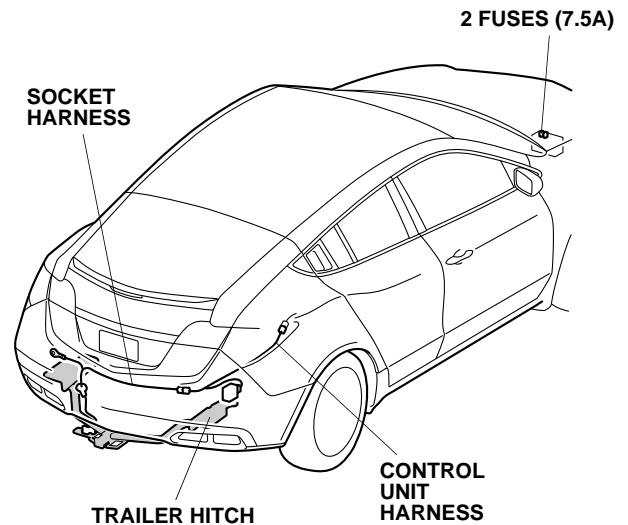

INSTALLATION

Client Information: The information in this installation instruction is intended for use only by skilled technicians who have the proper tools, equipment, and training to correctly and safely add equipment to your vehicle. These procedures should not be attempted by “do-it-yourselfers.”

NOTE:

- Do not damage the body paint finish.
 - Before removing any parts from the vehicle, note their location and how they are installed so they can be reinstalled in the original positions.
1. Make sure you have the anti-theft code for the audio unit and the navigation system (if equipped), then write down the radio station presets.
 2. Open the tailgate. Disconnect the negative cable from the battery.

3. Remove the cargo area front floor.

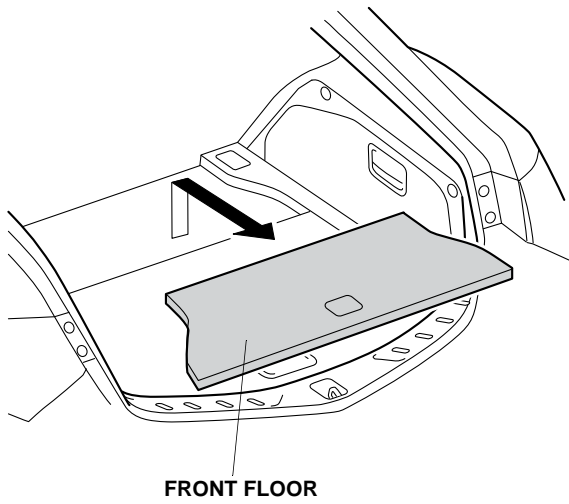

4. Remove the left and right rear tie-down hooks (open the lid and remove the screw).

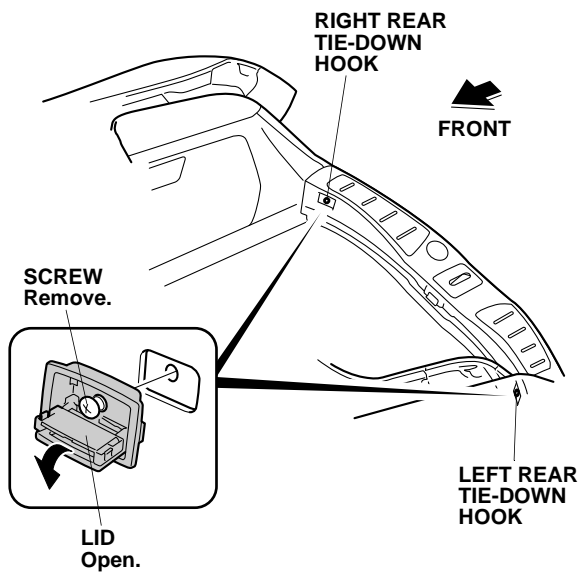

5. Pull away the weatherstrip in the area shown.

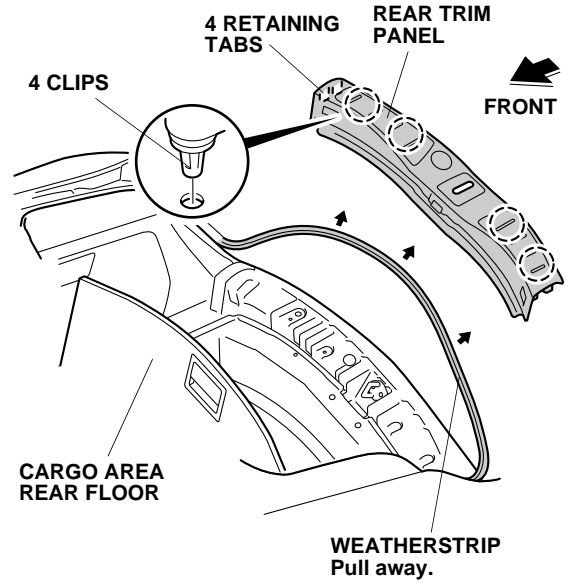

6. Open the cargo area rear floor.
7. Remove the rear trim panel (four retaining tabs and four clips).
8. Close the cargo area rear floor.
9. Remove the right front tie-down hook (open the lid and remove the screw).

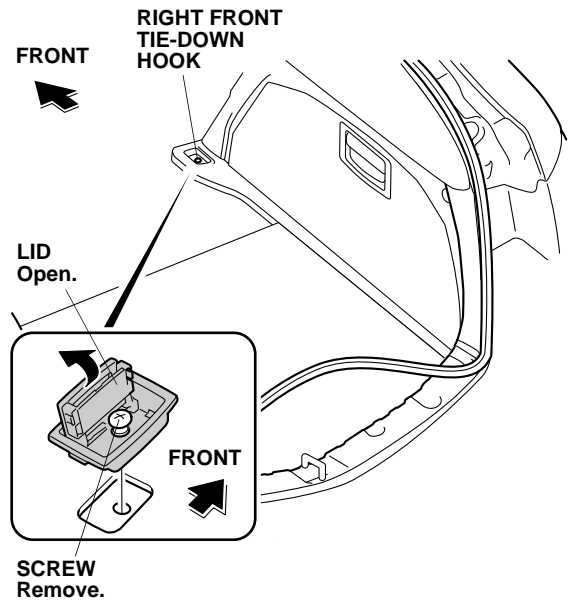

10. Fold down the right rear seat back.

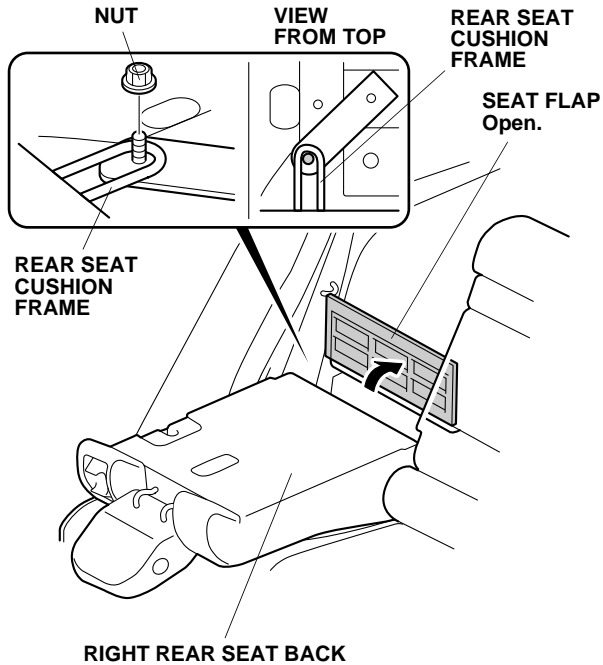

11. Open the seat flap. Remove the nut.
 12. Remove the rear seat cushion (lift up to unclip the two rear seat cushion loops, and unplug the vehicle connectors).

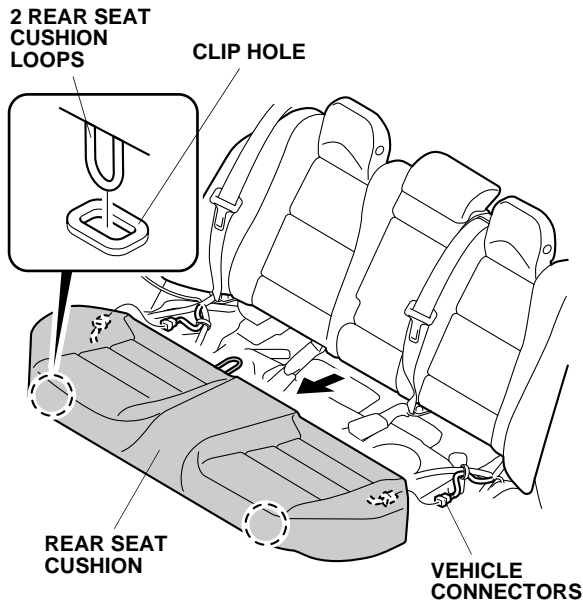

13. Remove the right rear seat bolster (one bolt and one clip).

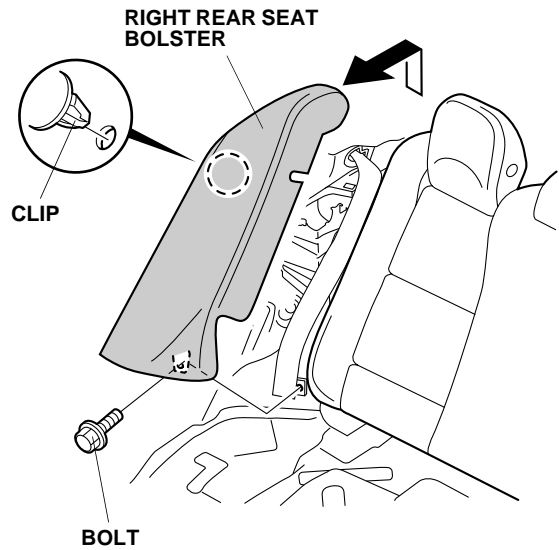

14. Remove the cargo area right side lid (lift the lever).

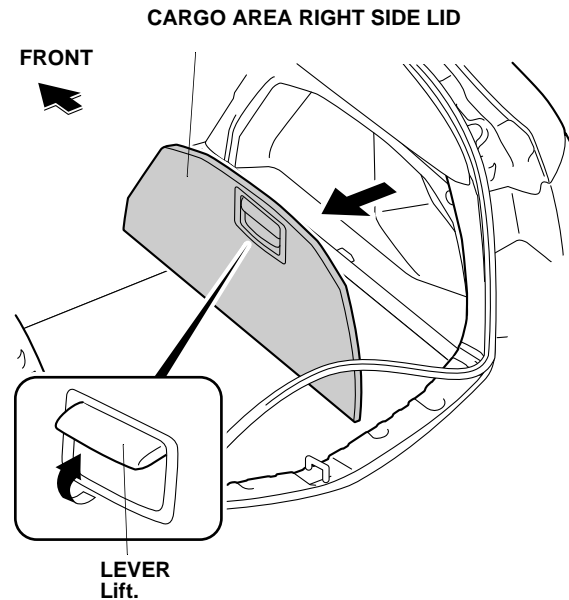

15. Remove the tool box.

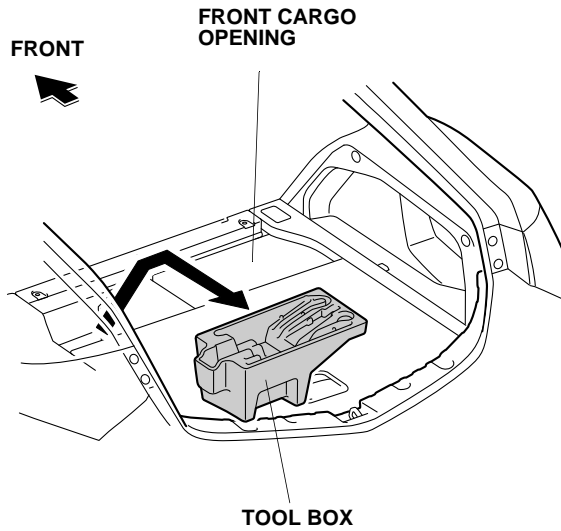

16. Remove the seat flap (two clips, one screw, and two tabs).

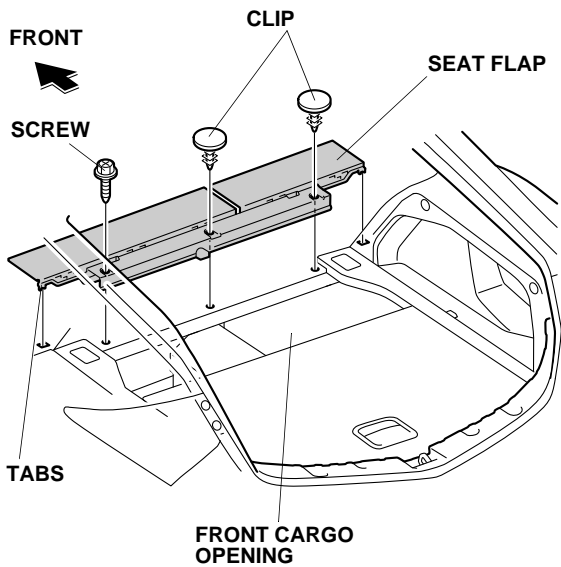

17. Pull away the weatherstrip in the area shown.

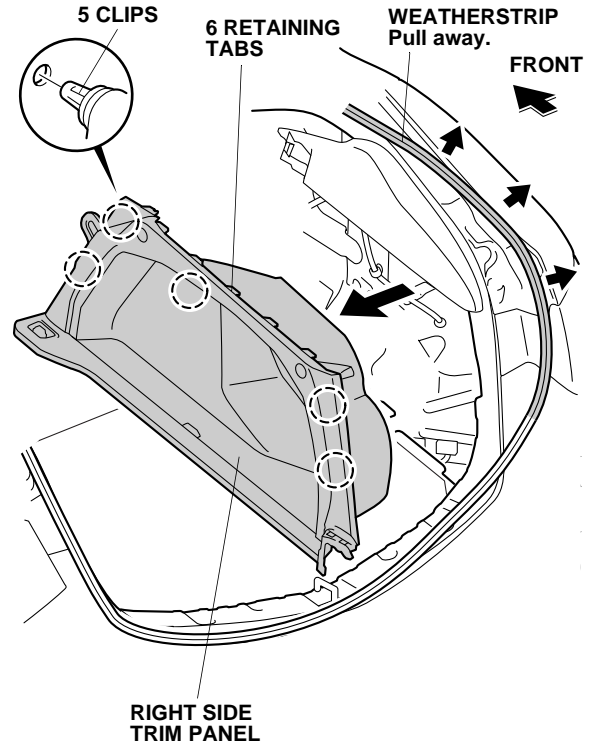

18. Remove the right side trim panel (six retaining tabs and five clips).

19. Open the cargo area rear floor. Release the rear under floor cover (three clips).

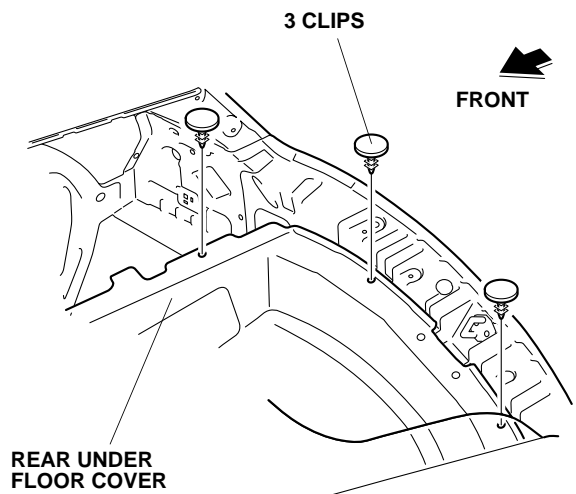

Installing the Trailer Hitch

20. Install the trailer hitch to the vehicle frame with two spacers, six spring washers, six plain washers, and six 10 x 40 mm hex bolts. Torque the hex bolts to 46 N·m (34 lbf·ft).

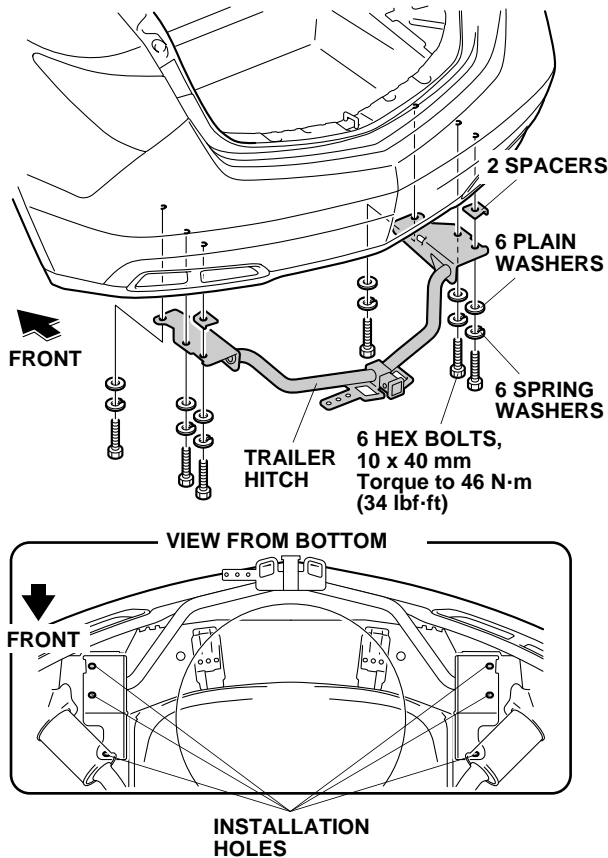

Routing the Socket Harness

21. Using isopropyl alcohol on a shop towel, thoroughly clean the rear panel where the EPT sealer will attach.

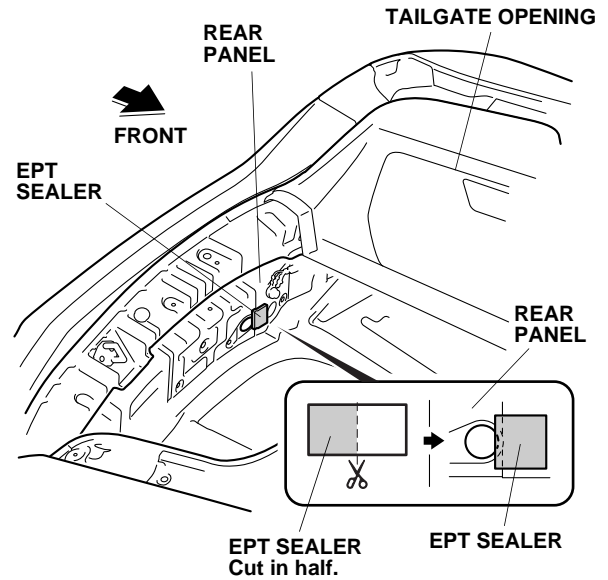

22. Using scissors, cut one EPT sealer in half. Attach one cut piece of EPT sealer to the rear panel as shown.
23. Secure the trailer socket to the trailer hitch with two 6 x 40 mm flange bolts.

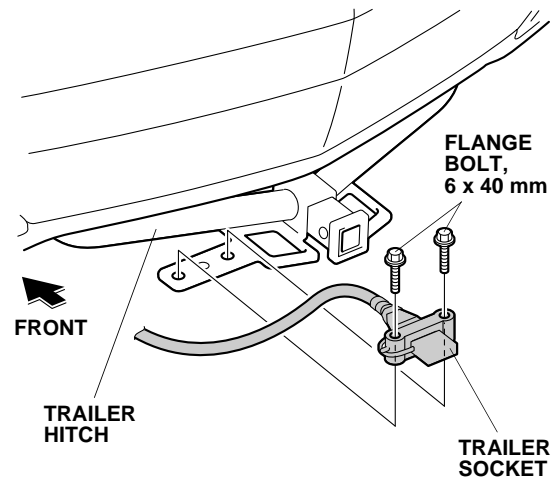

24. Remove the vehicle grommet from the vehicle panel.

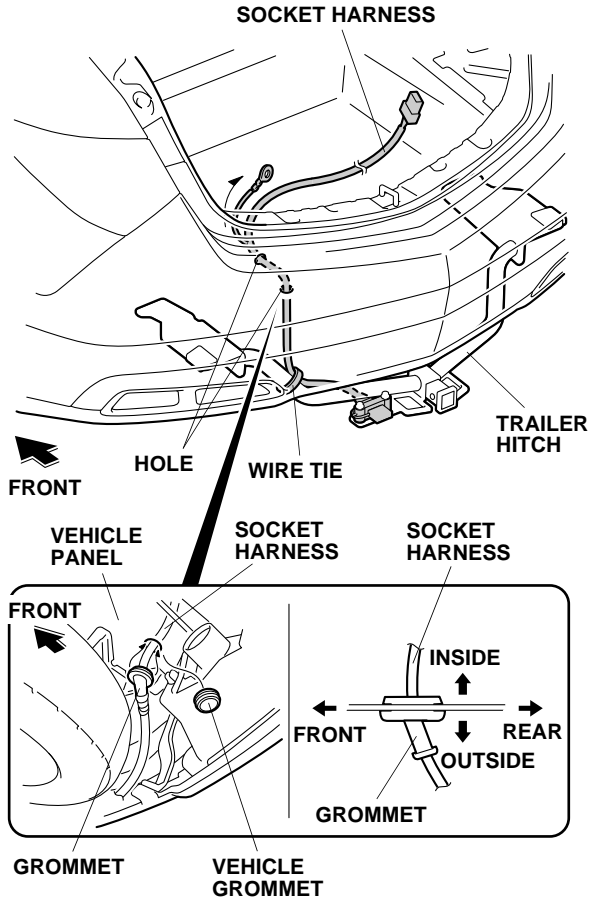

25. Route the socket harness through the panel holes and secure the socket harness grommet to the vehicle panel as shown.

26. Secure the socket harness to the trailer hitch with one wire tie.

27. Remove the vehicle ground bolt. Secure the socket harness ground terminal to the vehicle ground terminal using the ground bolt.

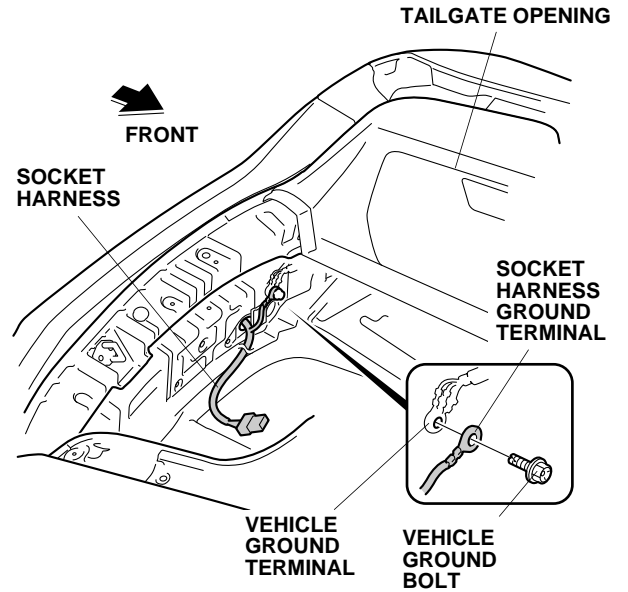

28. Route the socket harness as shown, and secure it to the vehicle panel with the two clips.

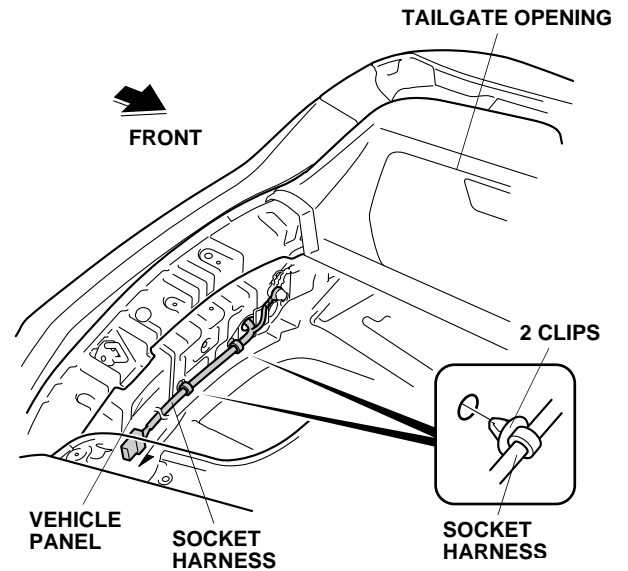

29. Continue routing the socket harness, and secure it to the vehicle panel with the two clips.

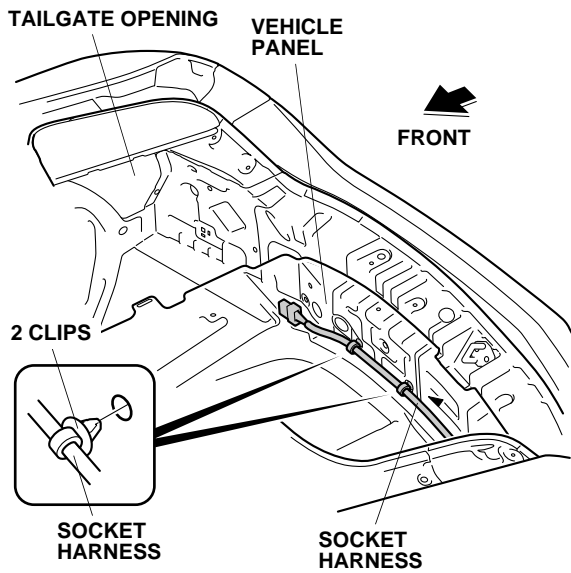

30. Plug the socket harness 4-pin connector into the control unit harness 4-pin connector.

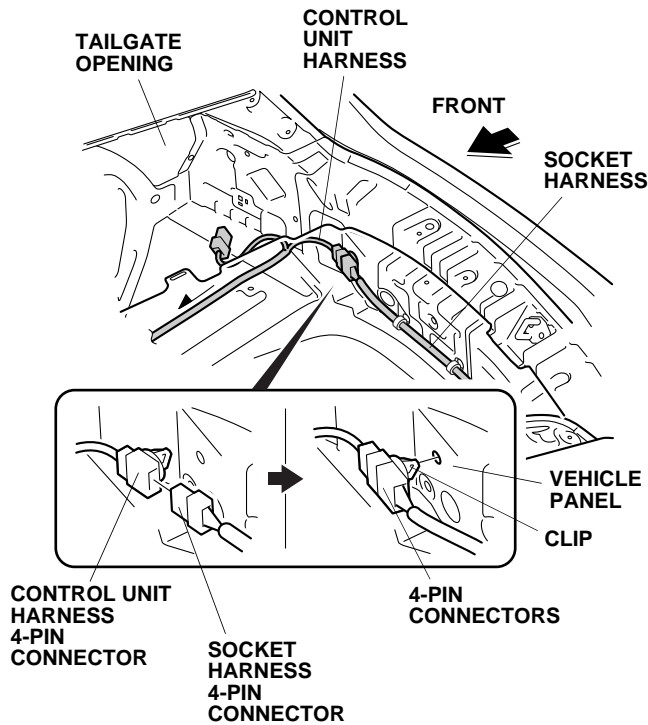

31. Secure the 4-pin connector to the vehicle panel with the clip on the control unit harness 4-pin connector.

Routing the Control Unit Harness

32. Install the control unit bracket to the control unit.

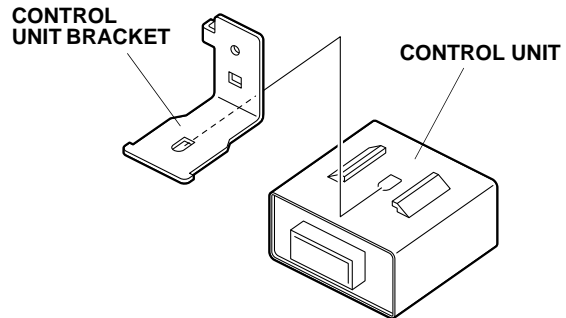

33. Insert one screw grommet into the vehicle panel as shown.

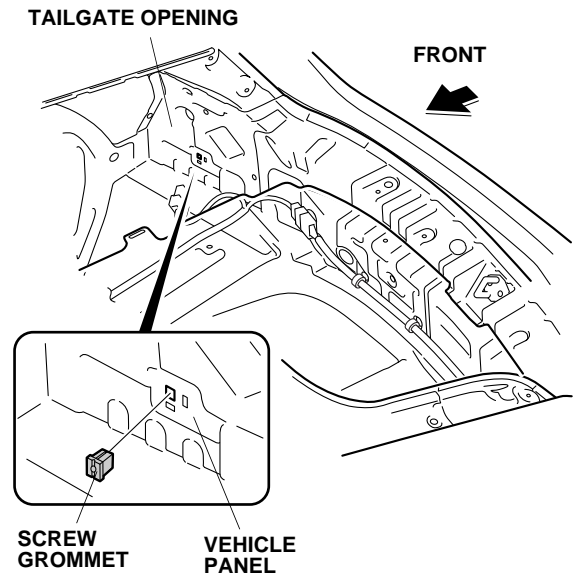

- Secure the control unit to the vehicle panel with one self-tapping screw.

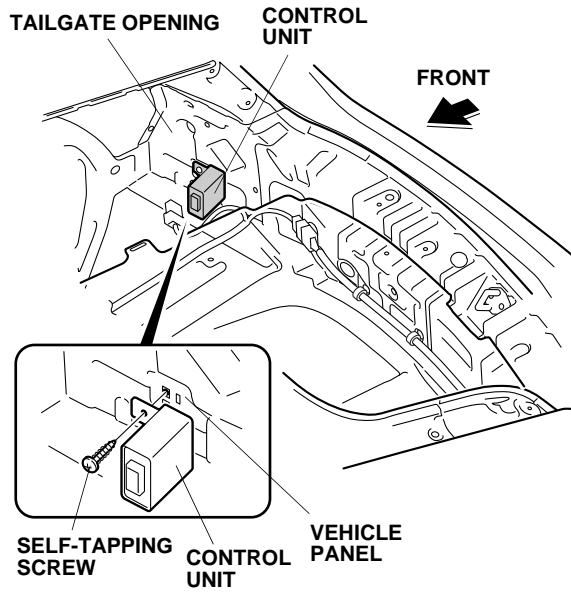

- Route the control unit harness as shown, and plug the 12-pin connector into the control unit.

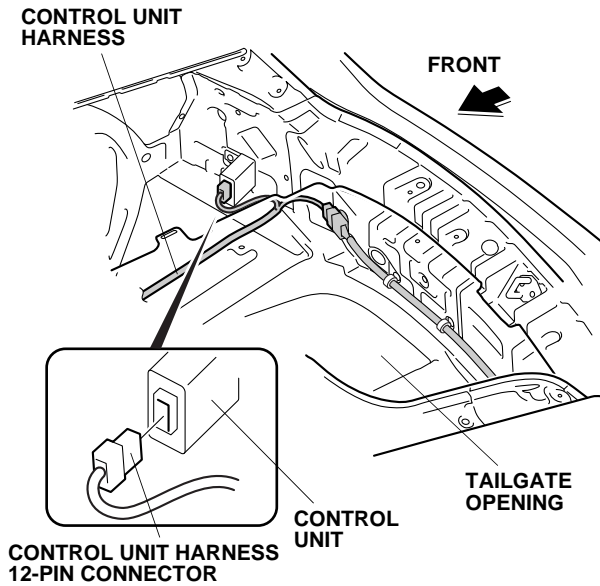

- Route the control unit harness along the vehicle harness, and secure it to the vehicle harness with four wire ties.

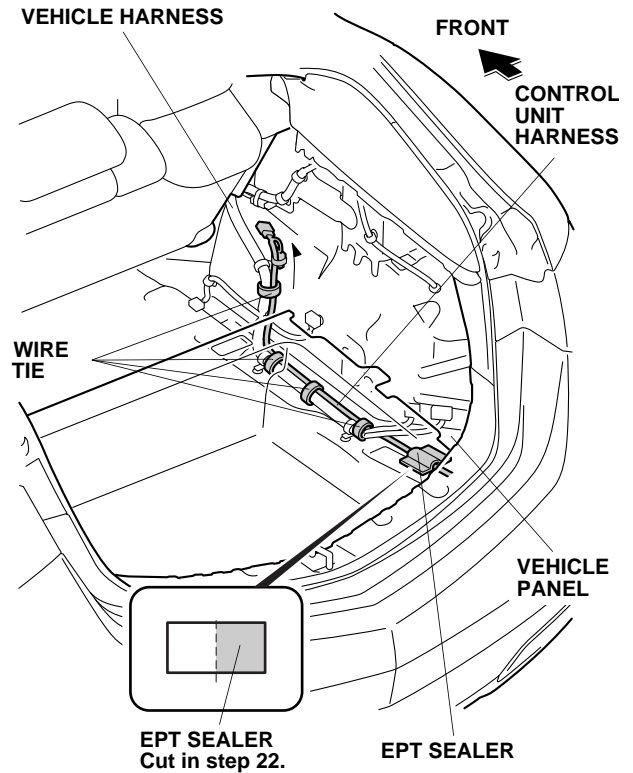

- Using isopropyl alcohol on a shop towel, thoroughly clean the floor where the EPT sealer will attach.
- Secure the control unit harness to the floor with the remaining piece of EPT sealer cut in step 22.

39. Remove the tape and dummy connector from the vehicle 8-pin connector.

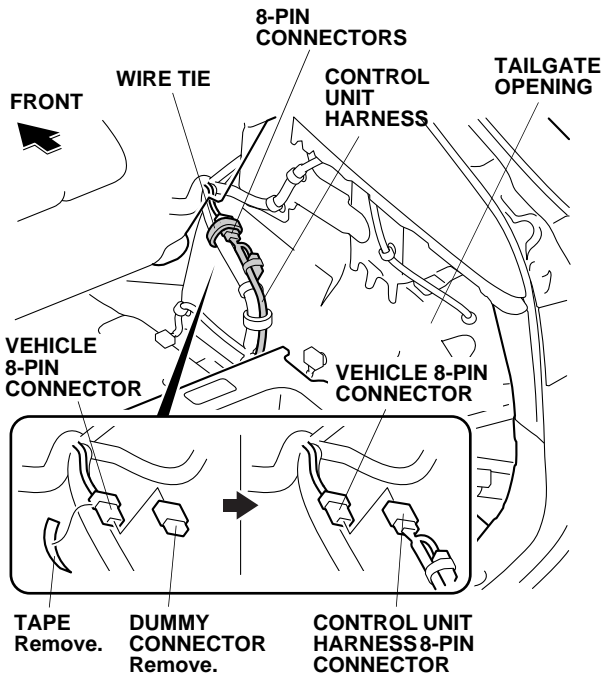

40. Plug the control unit harness 8-pin connector into the vehicle 8-pin connector. Secure the 8-pin connector to the vehicle harness with one wire tie.
41. If another accessory harness is already plugged into the vehicle 8-pin connector, unplug the other accessory harness 8-pin connector and plug it into the control unit harness 8-pin connector. Plug the control unit harness 8-pin connector into the vehicle 8-pin connector.

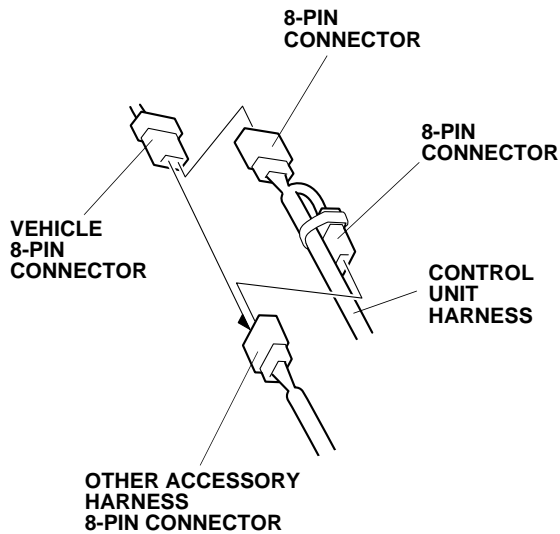

Installing the Fuses

42. Open the hood. Remove the fuse box cover (four retaining tabs).

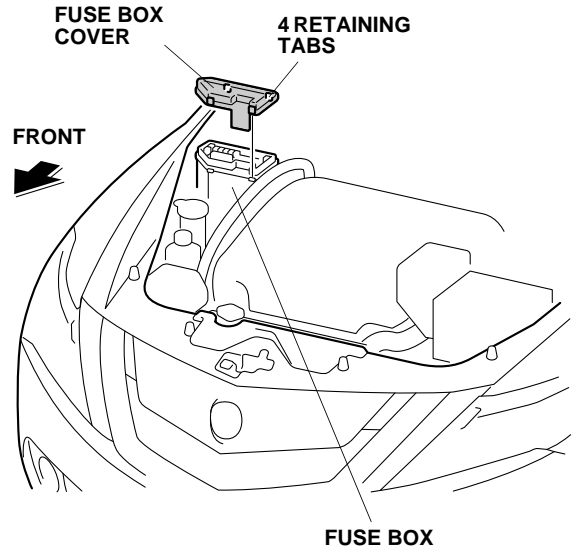

43. Install 7.5A fuses into the #9 and #11 slots in the fuse box. Reinstall the fuse box cover.

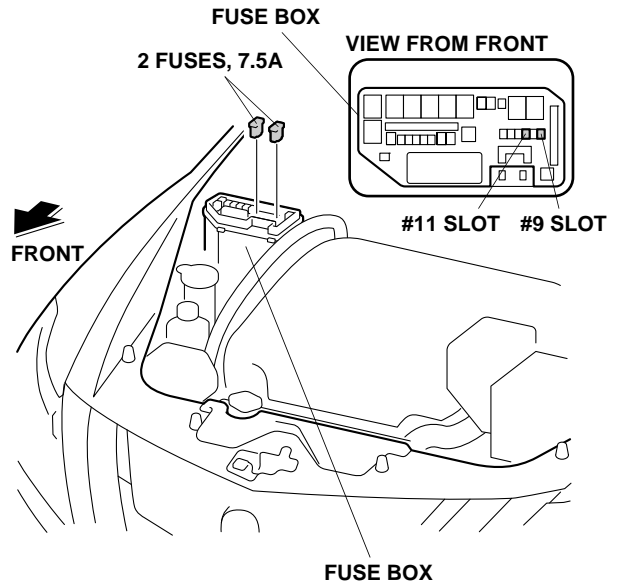

Installing the Ballmount

44. Slide the ballmount into the trailer hitch and secure it with the hitch pin and hitch pin clip.

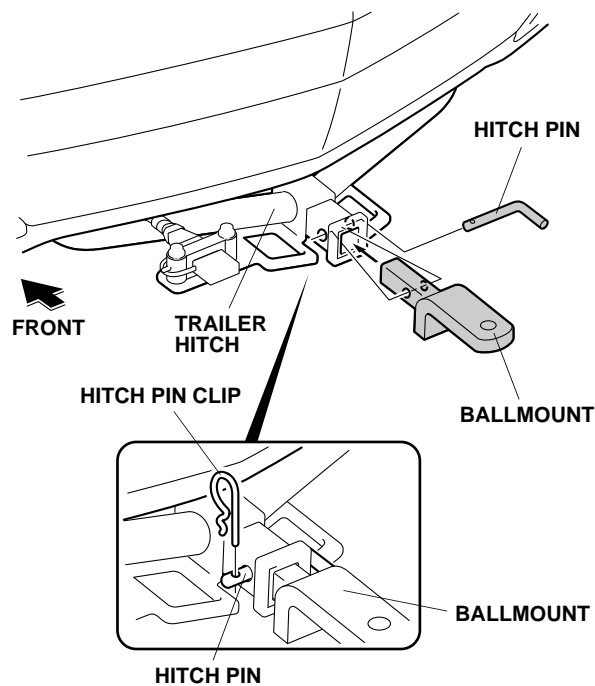

45. Check that all wire harnesses are routed properly and all connectors are plugged in.
46. Reinstall all removed parts.
47. Reconnect the negative cable to the battery.
48. Enter the anti-theft code for the audio and navigation system (if equipped), and reset the radio station presets.
49. Reset the clock.

Please Put a Copy of this Page in the Glove Box for Your Client

Installing the receiver cover

Whenever you remove the hitch pin clip, hitch pin and ballmount, securely store them in the cargo area. Then install the receiver cover into the opening at the end of the trailer hitch. When you reinstall the ballmount, store the receiver cover in the cargo area.

