



# INSTALLATION INSTRUCTIONS

Accessory  
**ENGINE BLOCK HEATER**  
P/N 08T44-SNA-101

Application  
**2013 ZDX**

Publications No.  
**BII 13518**  
Issue Date  
**OCT 2012**

## PARTS LIST

Engine block heater

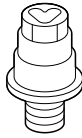

Aluminum washer



Heater harness

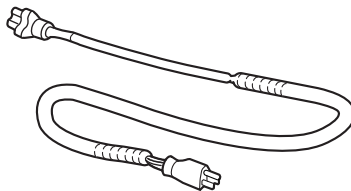

Protective cap

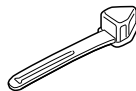

12 Black wire ties  
(5 Not used)

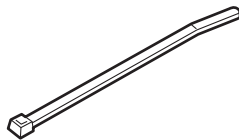

7 Wire ties with clips  
(6 Not used)

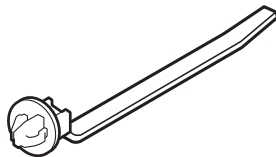

5 White wire ties

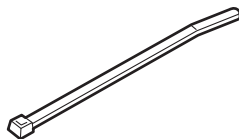

## TOOLS AND SUPPLIES REQUIRED

Phillips screwdriver

Ratchet

19 mm and 24 mm Sockets

Torque wrench

3 in. extension

Diagonal cutters

Heavy gloves

Drain pan

Tape measure

White marker

Coolant (Genuine Antifreeze/Coolant only)

Fender cover

Blanket

10 mm Wrench

## Illustration of the Engine Block Heater in the Vehicle

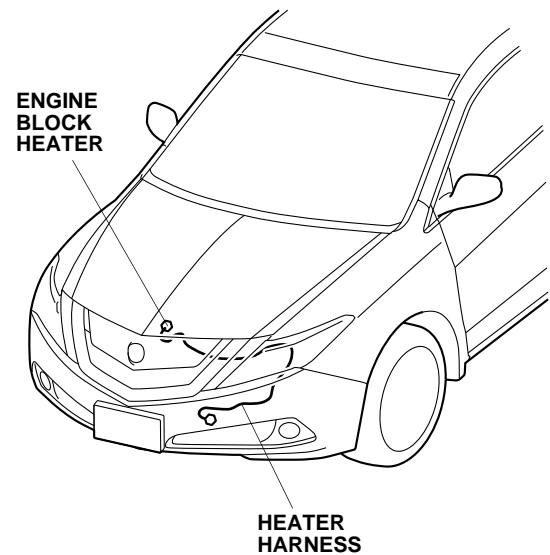

## INSTALLATION

### NOTE:

- Always use Acura Long Life Antifreeze/Coolant only. Using a non-Acura coolant can result in corrosion, causing the cooling system to malfunction or fail.
- To avoid burning the element, do not operate the engine block heater until you install it in the vehicle and add coolant.

**Client Information:** The information in this installation instruction is intended for use only by skilled technicians who have the proper tools, equipment, and training to correctly and safely add equipment to your vehicle. These procedures should not be attempted by “do-it-yourselfers.”

1. Make sure you have the anti-theft code for the audio unit and navigation system if equipped, then write down the radio stations presets.
2. Disconnect the negative cable from the battery.
3. Allow the engine and all cooling system components to cool down.
4. Place a drain pan under the radiator drain plug, then remove the drain plug from the bottom of the radiator to drain the coolant. Remove the radiator cap to increase the flow.

**NOTICE:** Coolant will damage the paint finish. Quickly rinse any spilled coolant from the painted surfaces.

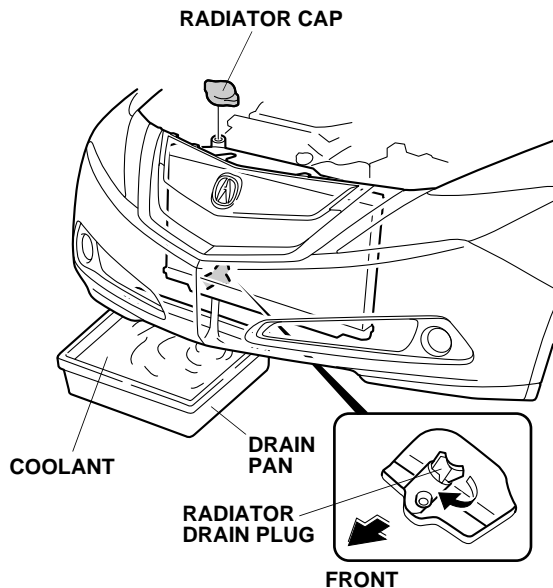

5. Remove the battery cover (three clips).

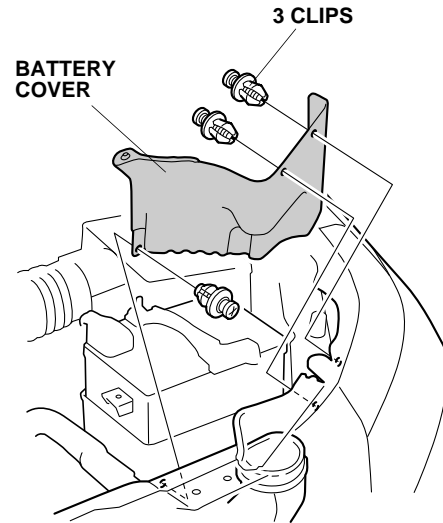

6. Locate and remove the drain bolt and washer. Coolant remaining in the engine jacket flows out of the bolt hole when the bolt is removed. Retain the bolt; it will be used if the engine block heater is removed.

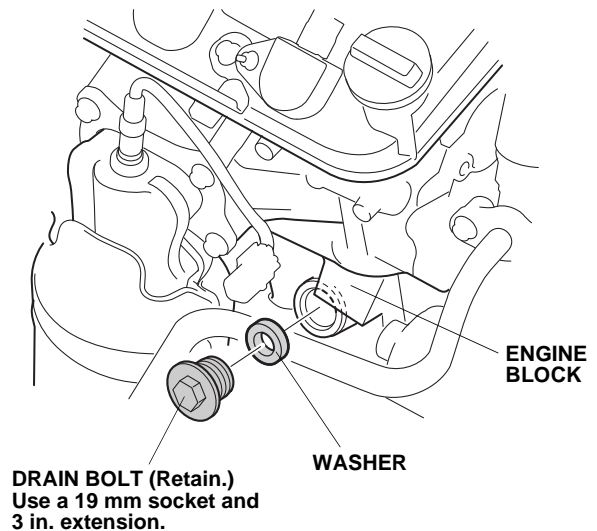

- Using a 24 mm socket and torque wrench, install the engine block heater with the aluminum washer into the engine block. Torque the engine block heater to 60 N·m (44 lbf·ft).

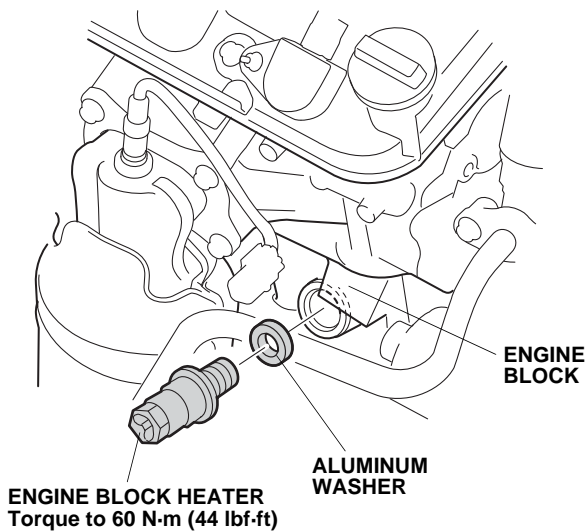

- Using a tape measure, secure one wire tie with clip to the heater harness as shown.

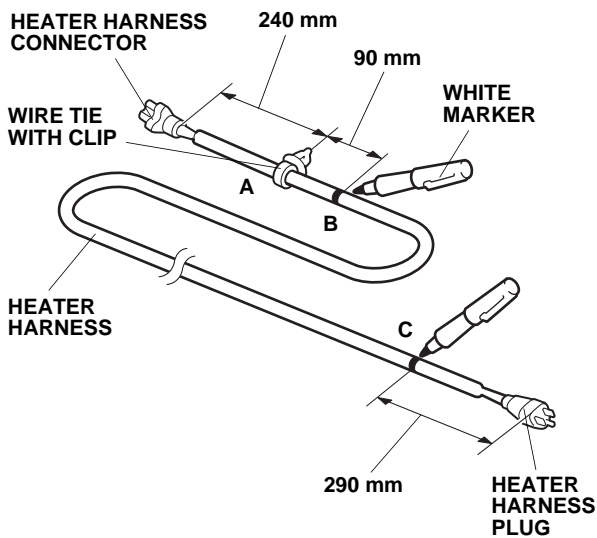

- Using a tape measure and white marker, measure and mark two points on the heater harness as shown.

- Plug the heater harness connector to the engine block heater.

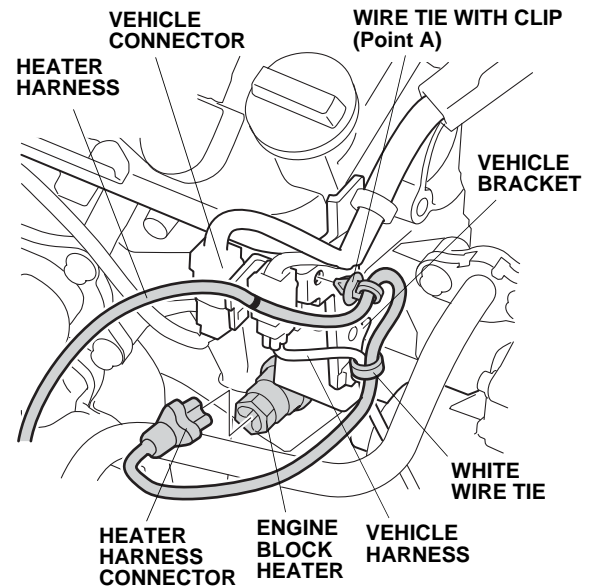

- Route the heater harness, and secure it to the vehicle harness with one white wire tie. Secure the heater harness to the vehicle bracket with the wire tie with clip (point A).
- Route the heater harness, and secure it to the fan shroud rib with one white wire tie (point B).

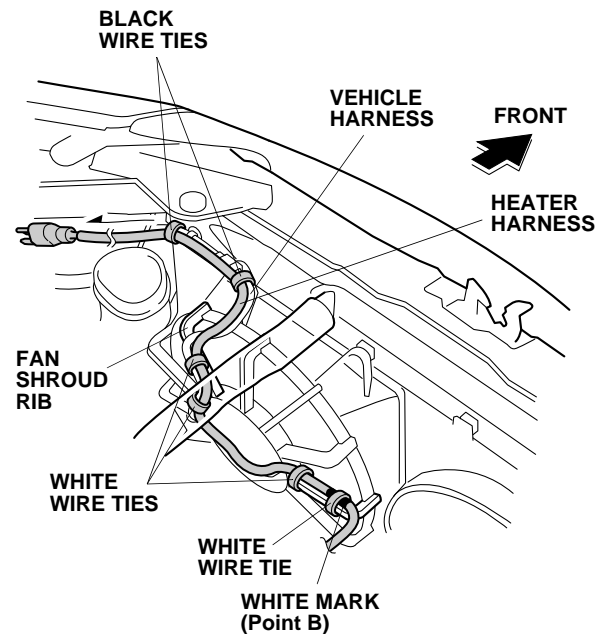

- Secure the heater harness to the fan shroud rib and vehicle harness with three white wire ties and two black wire ties.

- Join two black wire ties as shown.

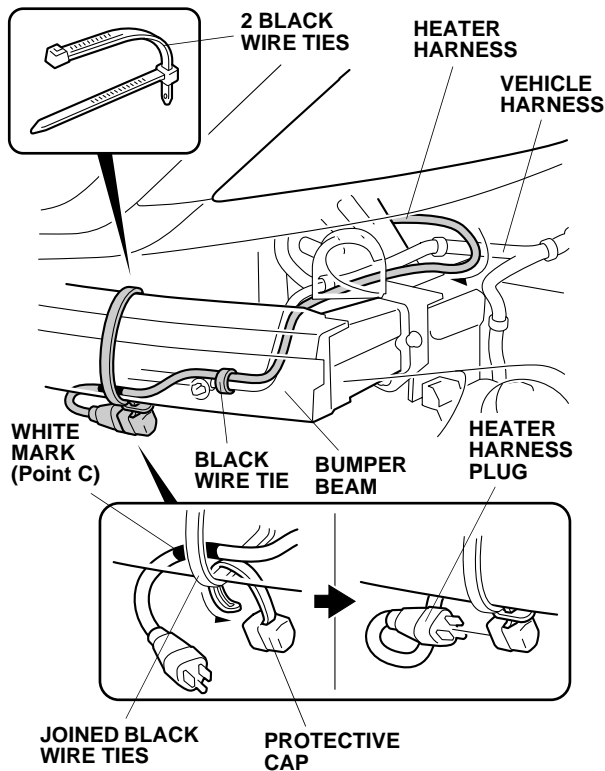

- Secure the protective cap around the joined black wire ties as shown. Align and secure the heater harness to the bumper beam with the joined black wire ties (Point C).
- Secure the heater harness plug in the protective cap.
- Route the heater harness along the bumper beam, and secure it to the vehicle harness with one black wire tie.

- Bundle the excess heater harness, and secure it to the vehicle harness with two black wire ties as shown.

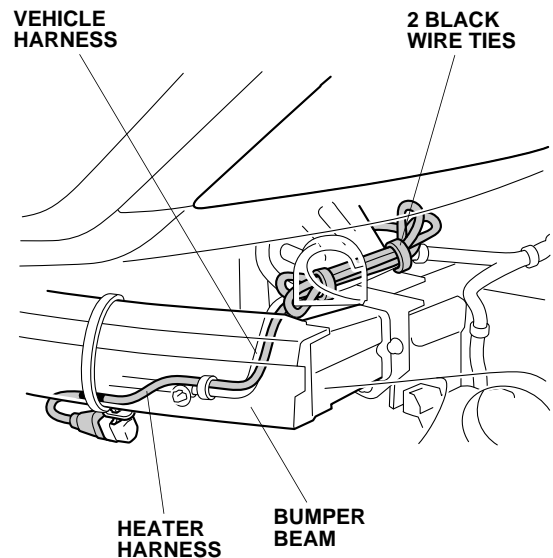

- Reinstall all removed parts, except for the radiator cap.
- Reinstall the radiator drain plug.
- Fill the system with the recommended coolant. Follow the instructions described in the service manual to fill and bleed the cooling system.
- Check the coolant reservoir for correct level and check the cooling system for signs of leakage. Repair as if necessary.
- Reinstall the radiator cap.
- Check that the harness is routed properly and all connectors are plugged in.
- Store the drain bolt in the glove box.
- Reconnect the negative cable to the battery.
- Enter the client's anti-theft code for the audio and navigation system, if equipped, and reset the radio station presets.
- Reset the clock.