



INSTALLATION INSTRUCTIONS

Accessory

18" ALUMINUM WHEEL
P/N 08W18-TL2-200
P/N 08W18-TL2-200A

Application

2013 TSX

Publications No.

BII 13468

Issue Date

SEP 2012

PARTS LIST

Aluminum wheel

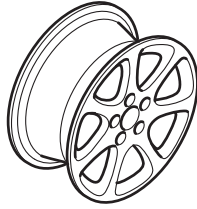

(The illustration may differ from the actual wheel.)

Wheel center cap

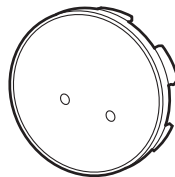

(The illustration may differ from the actual center cap.)

Center cap emblem

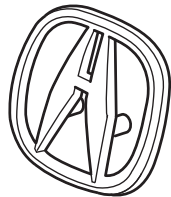

2 Push nuts



Tire pressure information label



TPMS Information

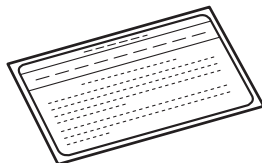

(Give this information to the client.)

Wheel cleaning information

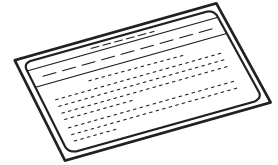

(Contained in the kit of 08W18-TL2-200 only.
Give this information to the client.)

Supplemental information

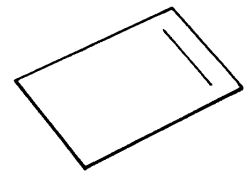

Parts for TPMS sensor assembly

Tire pressure sensor assembly

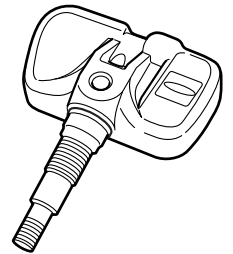

Washer



Valve cap



Valve nut



TOOLS AND SUPPLIES REQUIRED

Ratchet wrench
11 mm Socket
Torque wrench
Isopropyl alcohol
Shop towel
HDS
Snap-on TPMS initializer tool

SPECIFICATIONS

Models not equipped with standard 18" wheels:

Rim size	18 x 7 1/2 J (offset 55)	
Tire size	225/45ZR18 95Y	
Bolt hole PCD	114.3 (5 holes)	
Tire pressure	Front	260 kpa (2.6 kgf/cm ² , 38 psi)
	Rear	240 kpa (2.4 kgf/cm ² , 35 psi)

INSTALLATION

Client Information: The information in this installation instruction is intended for use only by skilled technicians who have the proper tools, equipment, and training to correctly and safely add equipment to your vehicle. These procedures should not be attempted by "do-it-yourselfers."

NOTE:

- This aluminum wheel is designed for use on vehicles equipped with the TPMS (Tire Pressure Monitoring System).
- This aluminum wheel is equipped with a TPMS sensor. See the service manual for the tire replacement procedure and TPMS sensor installation procedure.
- Install the correct size tire.
- Use a tire changer to remove and install the tires. Using a tire lever to remove and install the tires can damage the tire, the wheel, and the TPMS sensor.
- The wheel nut torque is 108 N·m (80 lb-ft).
- Be careful not to damage the wheel center cap when installing the emblems.
- The center cap emblem kit should be installed only if the ambient air temperature is 60°F (15°C) or above.
- To allow the adhesive to cure, do not wash the vehicle for 24 hours.

- Using isopropyl alcohol on a shop towel, clean the area where the center cap emblem will attach.

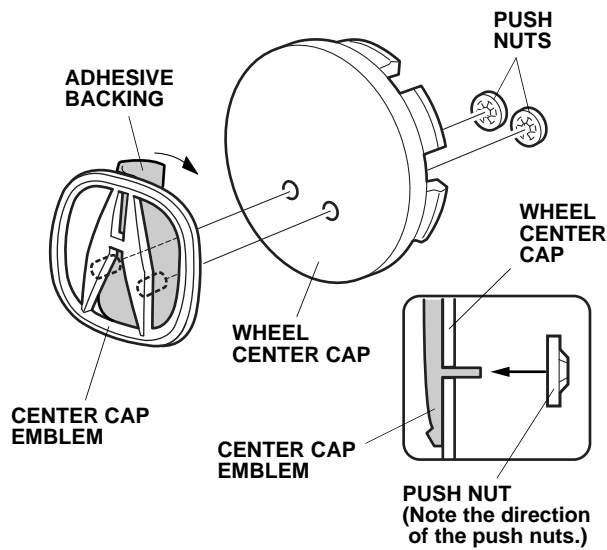

- Remove the adhesive backing from the center cap emblem.
- Attach the center cap emblem to the wheel center cap by aligning its pins with the holes in the wheel center cap. After attaching, hold the emblem firmly against the wheel center cap with the palm of your hands for 30 seconds.
- Slide the push nuts onto the pins. Note the direction of the push nuts.

- Before installing the tire pressure sensor, clean the mating surface on the sensor and the aluminum wheel.
- Install the tire pressure sensor and the washer to the aluminum wheel and tighten the valve nut finger tight. Make sure the pressure sensor is resting on the wheel.

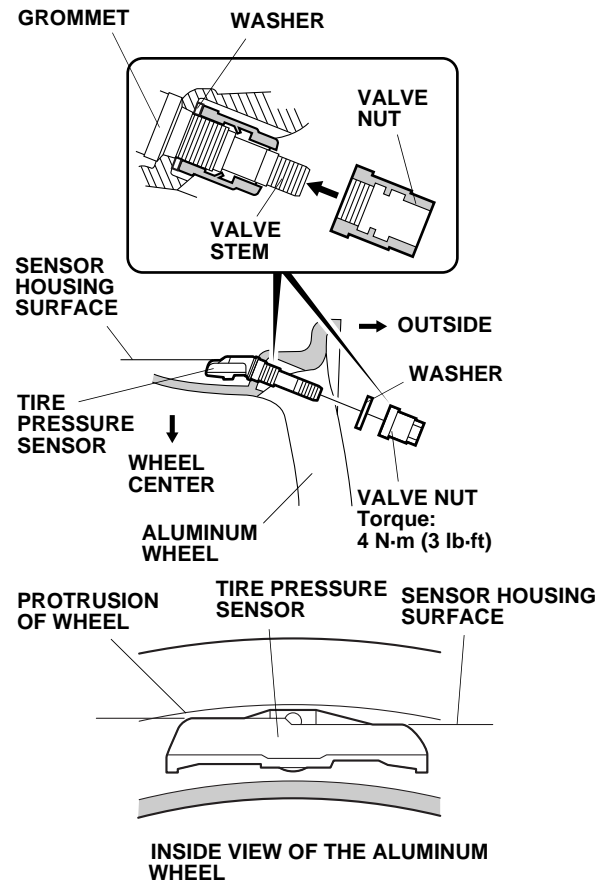

- While holding the tire pressure sensor to keep it from rotating, torque the valve nut to 4 N·m (3 lb·ft). You may hear a snap or pop as you torque the nut; this is normal.

NOTE: Install the tire pressure sensor so the sensor housing surface does not protrude into the bead area of the wheel.

NOTE:

- Do not reuse any grommet that has been tightened to the specified torque, even if it was only one time; the valve system may leak.
 - Do not use pneumatic or electric tools to tighten the valve nut.
 - Tightening the nut higher than the specified torque can damage the grommet.
 - Make sure that there is no space between the sensor and the wheel.
8. Install the tires according to the instructions in the service manual.
 9. Install the wheels on the vehicle and torque the wheel nuts to 108 N·m (80 lb·ft).

MEMORIZING THE TIRE PRESSURE SENSOR ID

10. Use the HDS and Snap-on TPMS sensor initializer tool to memorize the tire pressure sensor ID according to the instructions in the service manual (Memorizing the Tire Pressure Sensor ID).

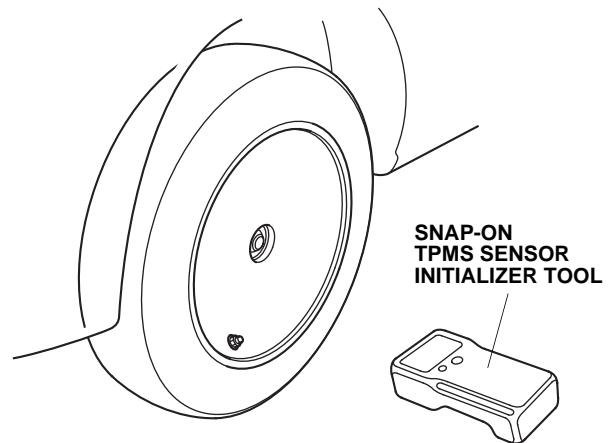
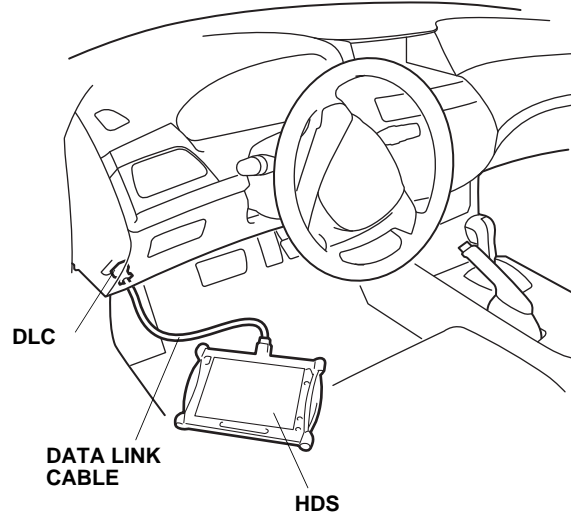

11. Open the driver's side door. Using isopropyl alcohol on a shop towel, thoroughly clean the area where the Tire Pressure Information Label will attach. Remove the adhesive backing from the label and attach it on the vehicle caution label as shown.

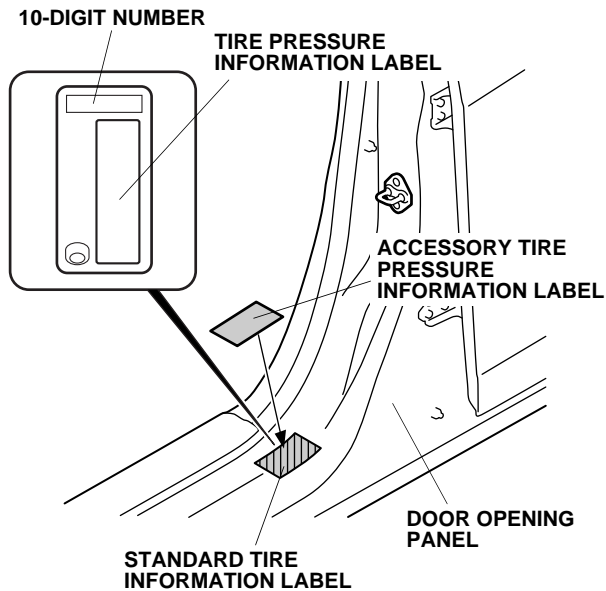

12. Attach the "Supplemental Information" page included in this kit to the owner's manual. Refer to the "Supplemental Information" page.
13. Do the inch-up tire pressure programming procedure on the next page.
14. After finishing the work, write the tire size, tire pressure, HDS version, dealer name, technician's signature and date in the "Service History Page for Acura Accessory Alloy Wheels" page included in this kit, and attach the page to the vehicle's service history booklet.

- Be sure to explain the contents of the "Supplemental Information" to the client before delivering the vehicle.
- Be sure to give the wheel cleaning information and TPMS information to the client.

INCH-UP TIRE PRESSURE PROGRAMMING (LOW AIR PRESSURE WARNING THRESHOLD REPROGRAMMING)

1. After doing the sensor ID learning using the HDS, back up to the TPMS Mode Menu, and click on Threshold Rewriting.
2. Select "Reprogramming for accessory tires."
3. When the HDS says "Do you want to rewrite the threshold data?" Select "YES".
4. Check that "Please enter the tire information code of new tires" is shown, and select the "Key board" icon.
5. Enter the 10-digit tire information code printed on the new tire pressure information label, then select OK.
6. Check that the tire pressure shown on the HDS, and the new tire pressure on the tire information label are the same, click "YES" button for programming.
7. Check that the current air pressure setting shown on the HDS is correct and "Reprogramming the threshold data for non-standard tires has completed successfully" is shown.
8. After programming, write the tire pressure indicated on the HDS in the service history page for Acura Accessory Alloy Wheels, then select OK.

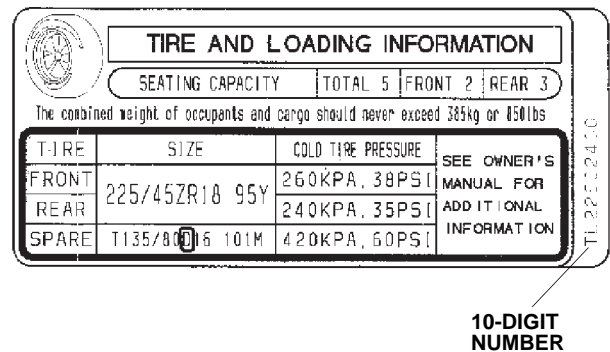
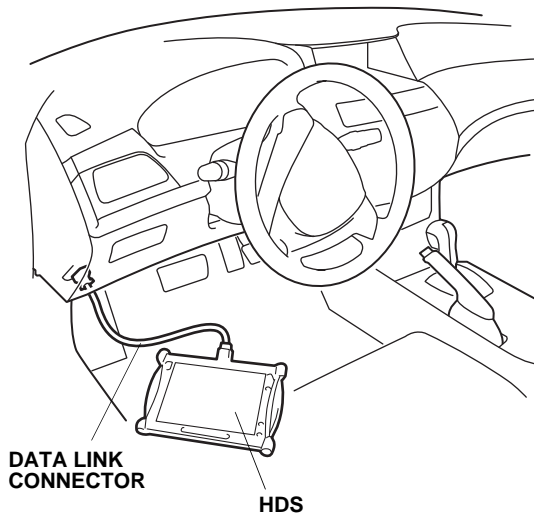

STANDARD TIRE PRESSURE PROGRAMMING

If the original equipment (standard tires) are reinstalled on the vehicle, the low pressure warning threshold must be restored to the factory setting.

NOTE: Have the standard tire pressure label on hand.

1. Replace with the standard tire, and perform memorizing the tire pressure sensor ID procedure according to the instructions in the service manual.
2. Change the tire pressure programming (the low air pressure warning threshold) in the following procedure.
 1. Connect the HDS to the vehicle, make sure the correct VIN is populated and enter the mileage.
 2. At the System Selection Menu, click TPMS.
 3. At the Mode Menu, click the DTC and clear any stored codes.
 4. Go back to the Mode Menu, click on Threshold Rewriting.
 5. Click on Reprogramming for standard tires and follow the screen prompts.
 6. After programming, write the standard tire pressure in the important information, then click the check button.
 7. Attach the tire pressure information label for standard tire at the prescribed location.
 8. After programming, sign on the service history page for Acura Accessory Alloy Wheels.
 9. Write the tire size, tire pressure, HDS version, dealer name, technician's signature and date on the service history page for Acura Accessory Alloy Wheels attached to the vehicle's service history booklet.

THRESHOLD DATA CHECK

If you are unsure of where the low pressure warning threshold is set, it can be checked by using Threshold Data Check.

Check the TPMS programming on the vehicle:

1. Connect the HDS to the vehicle and make sure the correct VIN is populated and enter the mileage.
2. At the System Selection Menu, click TPMS.
3. Click on Threshold Rewriting.
4. Click on Threshold Data Check.

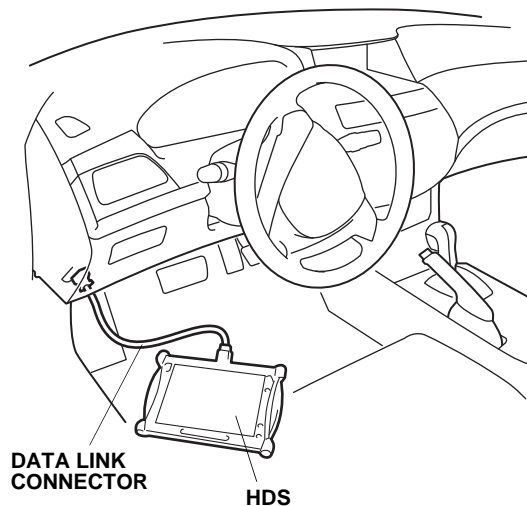

TPMS Unit Replacement

If the TPMS control unit is replaced, follow steps 10 to 14 (Memorizing the tire pressure sensor ID and inch-up Tire Pressure Programming.).