



INSTALLATION INSTRUCTIONS

Accessory
SPORT RUNNING BOARDS
P/N 08L33-STX-200F

Application
2013 MDX

Publications No.
BII 13439
Issue Date
JULY 2012

PARTS LIST

Right running board

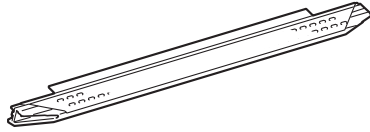

Left running board



Right front end cap

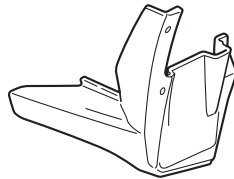

Left front end cap

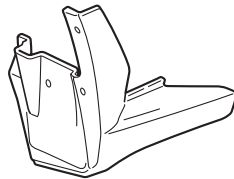

Right rear end cap

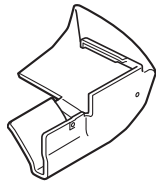

Left rear end cap

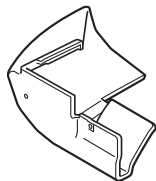

2 Self-tapping screws



4 Screws



4 Flange nuts, 6 mm



2 Brackets A

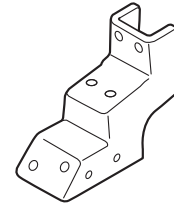

4 Brackets B

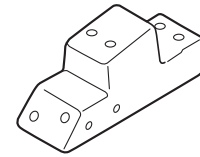

24 Flange bolts



12 Flange nuts, 8 mm



Right center trim

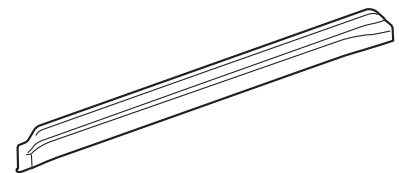

Left center trim

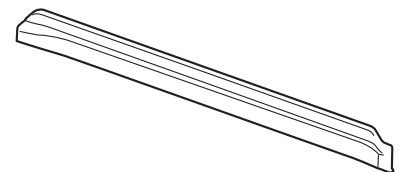

TOOLS AND SUPPLIES REQUIRED

Stubby Phillips screwdriver
Clip remover
Ratchet
10 mm and 13 mm Sockets
10 mm Combination wrench
Torque wrench
Scraper

INSTALLATION

Client Information: The information in this installation instruction is intended for use only by skilled technicians who have the proper tools, equipment, and training to correctly and safely add equipment to your vehicle. These procedures should not be attempted by “do-it-yourselfers.”

NOTE:

- Thoroughly clean the bottom of the body between the front and rear wheels.
- Be careful not to damage the paint finish.
- These instructions show the left running board being installed; the same procedure applies to installing the right running board.

1. Turn the steering wheel fully counterclockwise.
2. Remove the left front splash guard (five self-tapping screws).

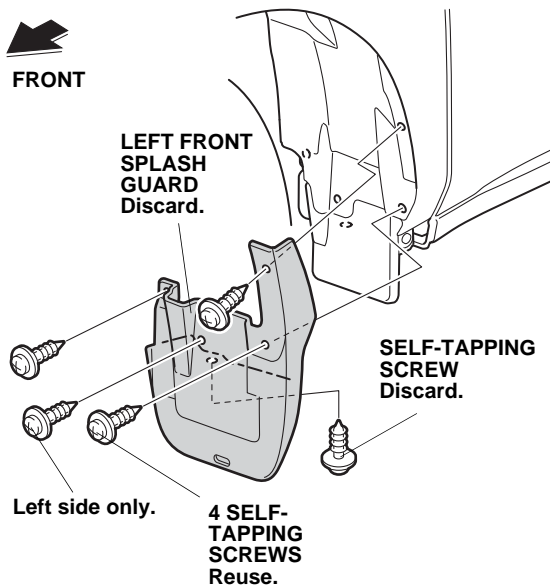

3. Remove the three clips and one self-tapping screw from the left side sill panel.

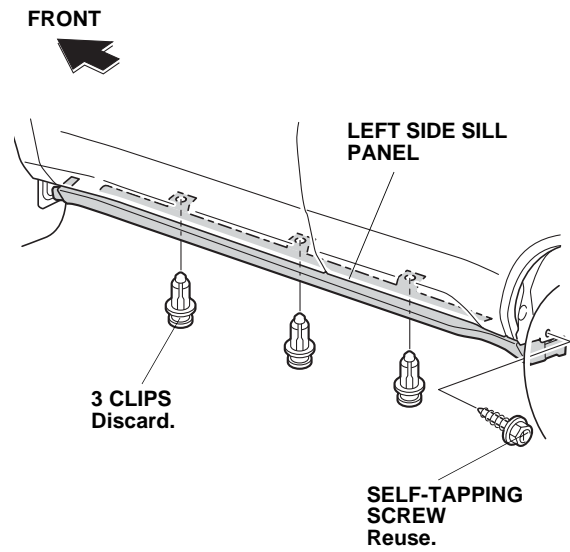

4. Open the front door and rear door.

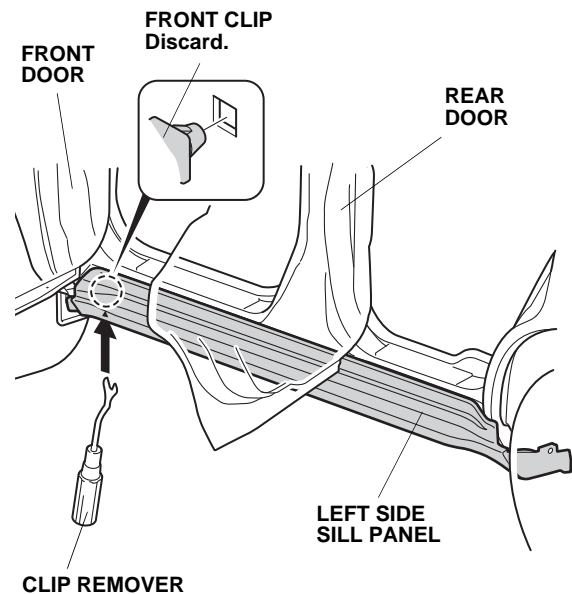

5. Using a clip remover, release the front clip from the back of the left side sill panel.

6. While pulling the front portion of the left side sill panel away from the body, slide the left side sill panel forward and remove it. The 11 side clips will stay in the body.

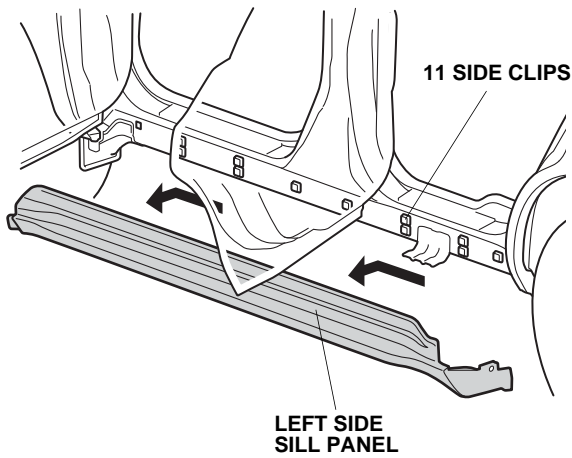

7. Remove the spring nut from the left side sill panel.

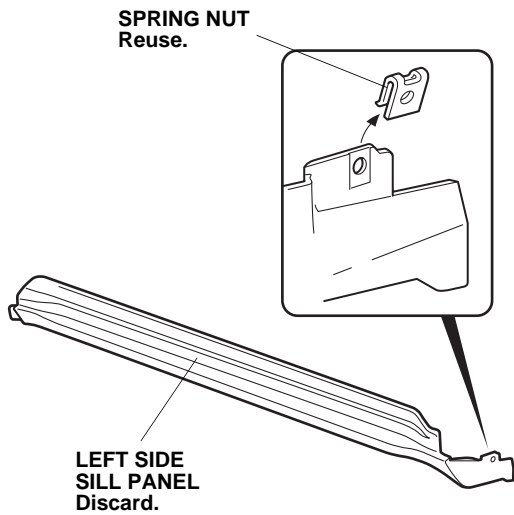

8. Remove the 11 side clips from the body by turning them 45 degrees.

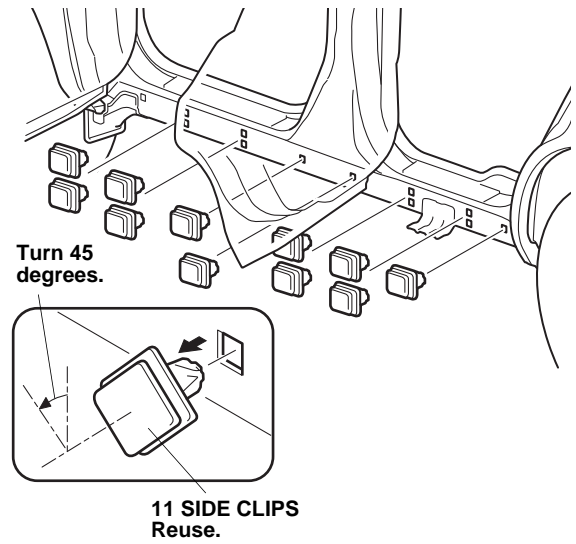

9. Remove the vehicle bracket (two bolts), and reinstall the two bolts.

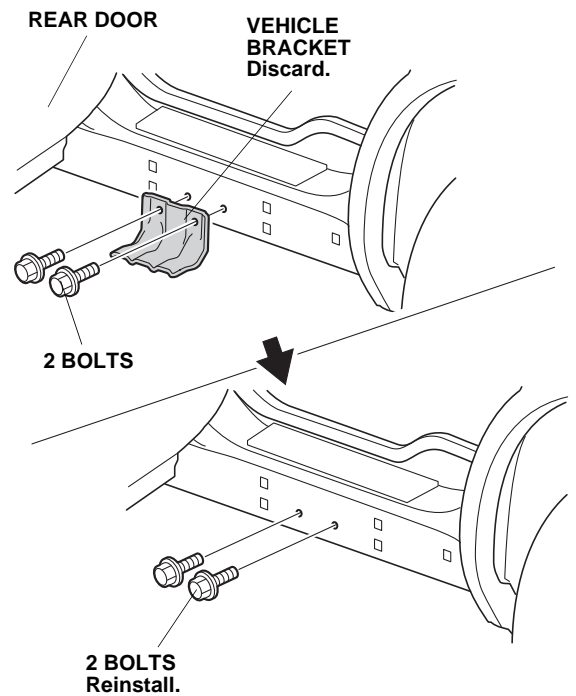

10. Install the 11 side clips to the left center trim.

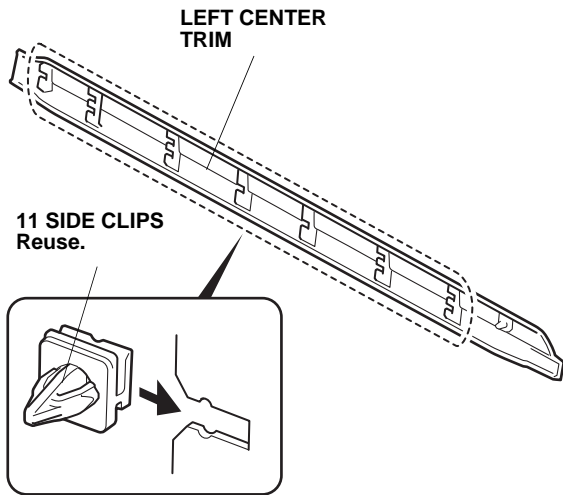

11. Align the front clip and 11 side clips with the holes in the body, then push on the left center trim until the side clips snap into place.

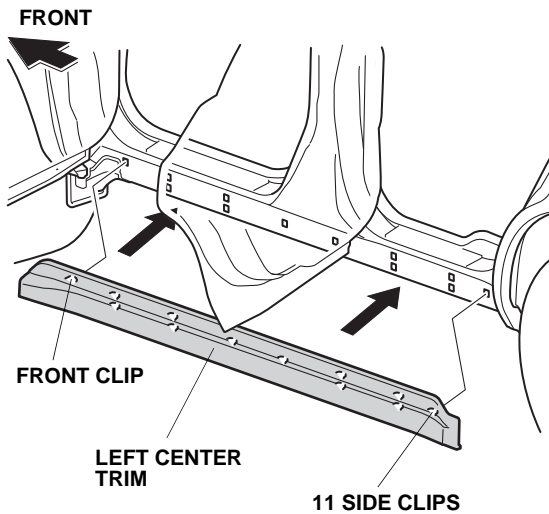

12. Close the front door and rear door.

13. Position bracket A on the vehicle frame. Install bracket A to the vehicle frame with four flange bolts. Do not tighten the flange bolts yet. Make sure the flange bolts are installed in the correct locations.
- NOTE: If there is undercoat on the body surface where the brackets will attach, use a scraper to remove the undercoat before installing the brackets. If necessary, clean the threads using a tap. Take care not to damage the paint finish.

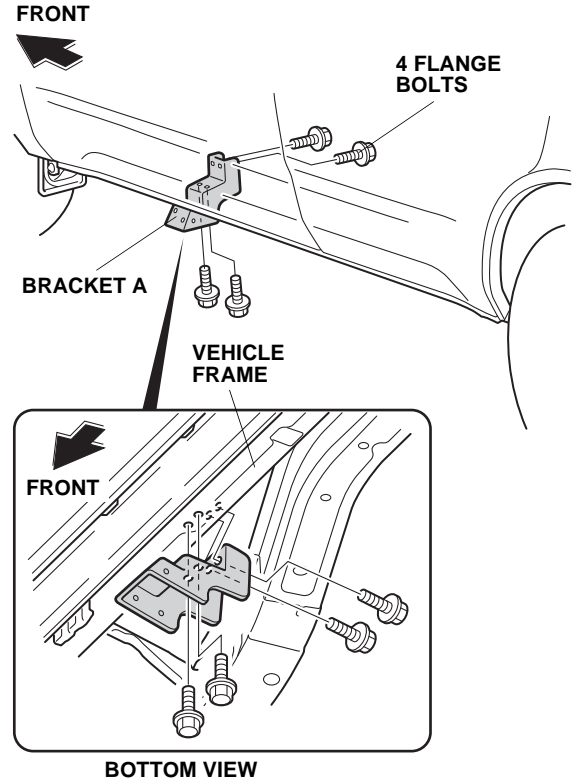

14. Position two brackets B on the vehicle frame. Install the two brackets B to the vehicle frame with four flange bolts for each. Do not tighten the flange bolts yet. Make sure the flange bolts are installed in the correct locations.

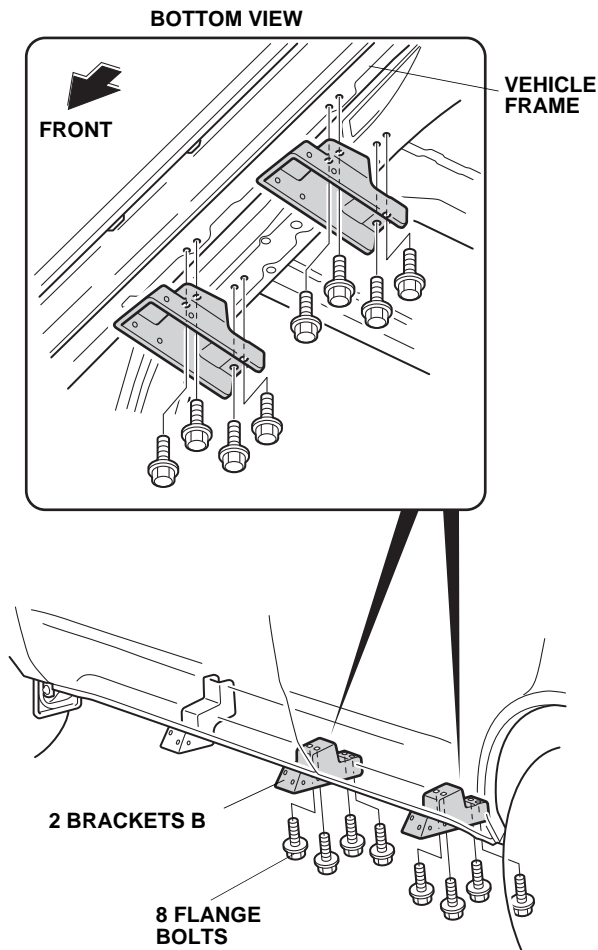

15. Install the left front end cap to the left running board with one screw and one 6 mm flange nut.

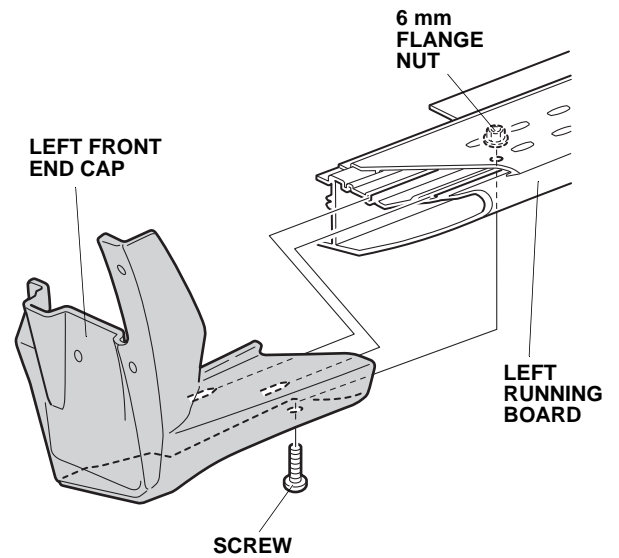

16. Install the left rear end cap to the left running board with one self-tapping screw, one screw, and one 6 mm flange nut.

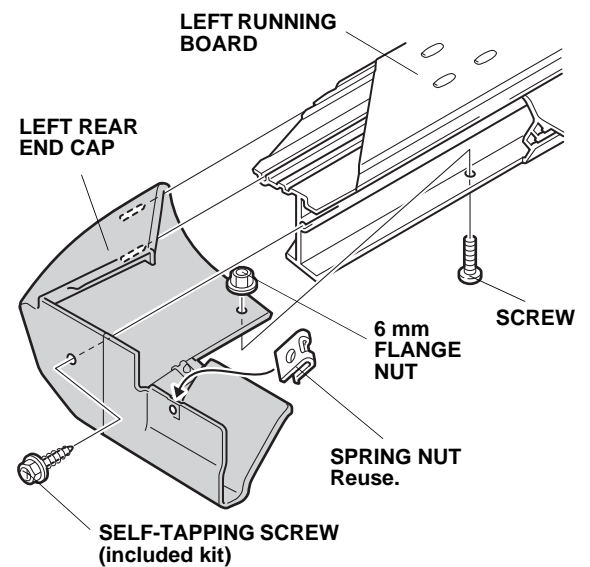

17. Install the spring nut to the left rear end cap.

- Remove the wrapper that secures the bolts to the running board. Align the six bolts with the six holes in brackets A and B. While applying forward pressure on the left running board, install it with six 8 mm flange nuts. Do not tighten the flange nuts yet.

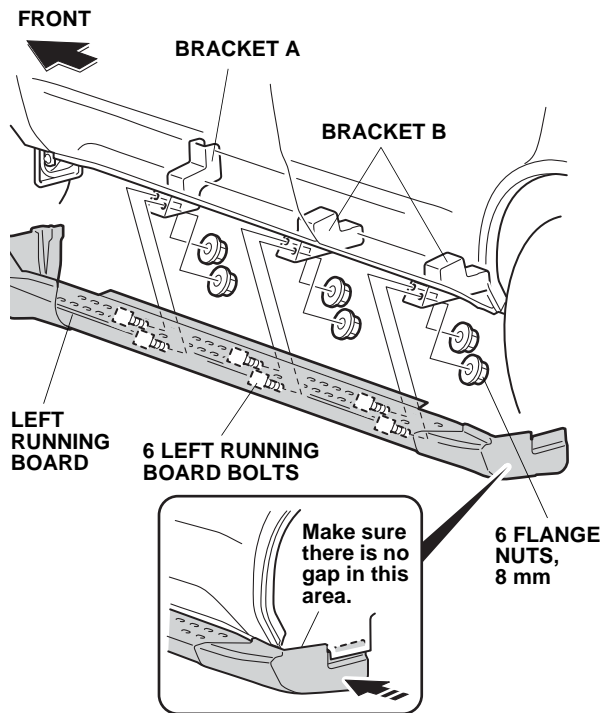

- Secure the rear portion of the left rear end cap with the self-tapping screw removed in step 3.

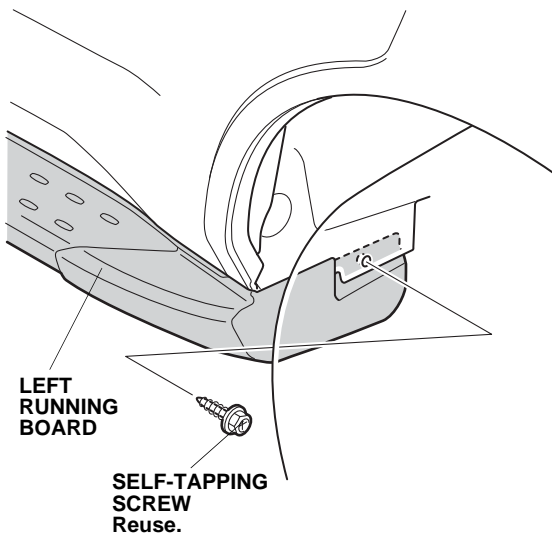

- While pushing up on the left running board, secure the left front end cap with four of the self-tapping screws removed in step 2. Do not tighten the self-tapping screws yet. (The right front end cap uses only three self-tapping screws.)

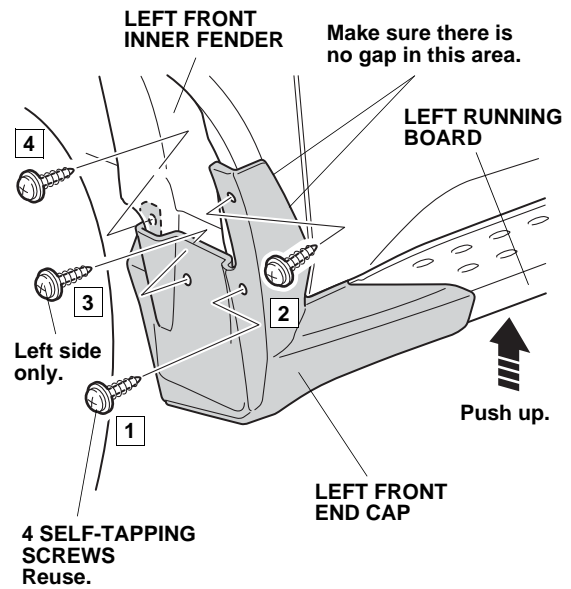

- While holding the left front end cap against the left front inner fender, tighten the self-tapping screws in the order shown.
- Torque all the flange bolts and the 8 mm flange nuts to 27 N·m (20 lbf·ft).
- Turn the steering wheel all the way clockwise, and repeat steps 2 thru 22 to install the right running board.