



# INSTALLATION INSTRUCTIONS

Accessory  
**PREMIUM RUNNING BOARDS**

Application  
**2013 MDX**

Publications No.  
**BII 13428**  
Issue Date  
**JULY 2012**

## PARTS LIST

2 Running boards

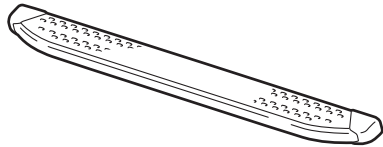

Right bracket A

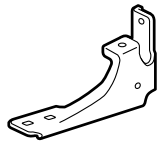

Left bracket A

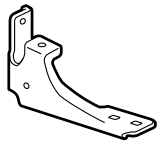

2 Right brackets B

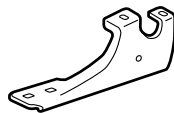

2 Left brackets B

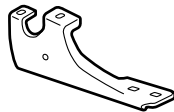

12 Flange bolts



12 Flange nuts



12 Square head bolts

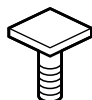

Right side sill panel

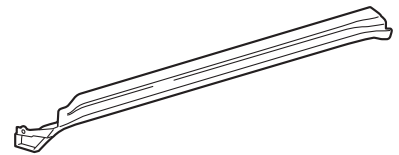

Left side sill panel

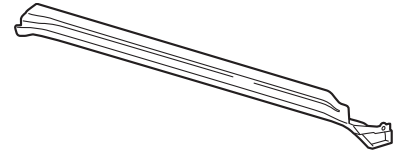

Right front splash guard

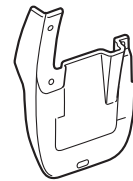

Left front splash guard



## TOOLS AND SUPPLIES REQUIRED

Stubby Phillips screwdriver  
Clip remover  
Ratchet  
10 mm and 13 mm Sockets  
Torque wrench  
Scraper

## INSTALLATION

**Client Information:** The information in this installation instruction is intended for use only by skilled technicians who have the proper tools, equipment, and training to correctly and safely add equipment to your vehicle. These procedures should not be attempted by “do-it-yourselfers.”

### NOTE:

- Thoroughly clean the bottom of the body between the front and rear wheels.
  - Be careful not to damage the paint finish.
  - These instructions show the left side running board being installed; the same procedure applies to installing the right side running board.
1. Turn the steering wheel all the way counterclockwise.

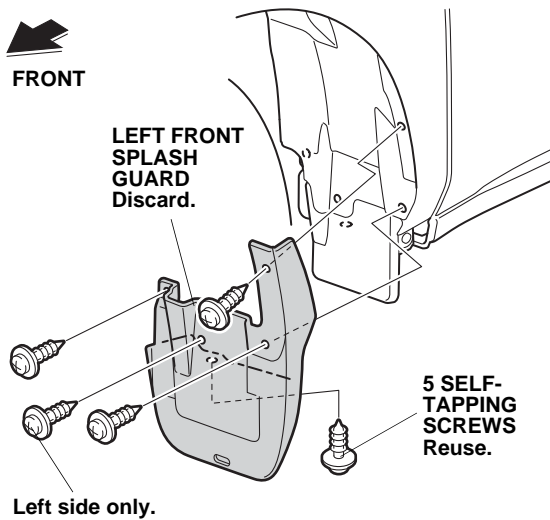

2. Remove the left front splash guard (five self-tapping screws).

3. Remove the three clips and one self-tapping screw from the left side sill panel.

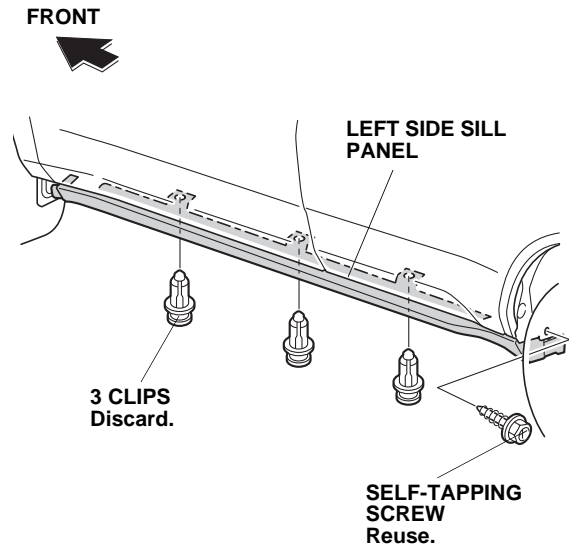

4. Open the front and rear doors.

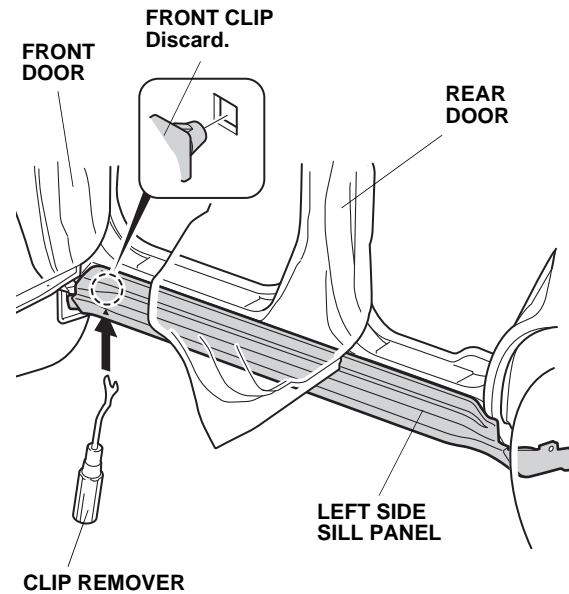

5. Using a clip remover, release the front clip from the back of the left side sill panel.

6. While pulling the front portion of the left side sill panel away from the body, slide the left side sill panel forward and remove it. The 11 side clips will stay in the body.

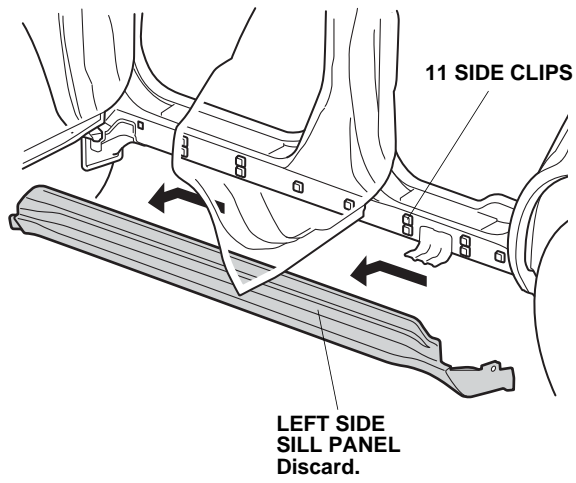

7. Remove the 11 side clips from the body by turning them 45 degrees. Discard the clips.

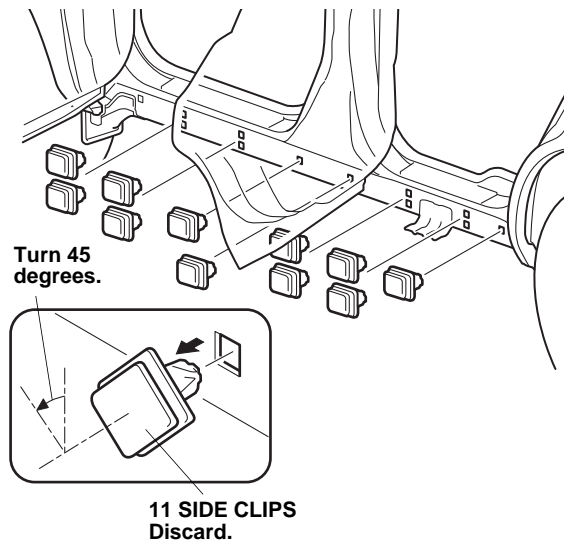

8. Remove the vehicle bracket (two bolts), and reinstall the two bolts.

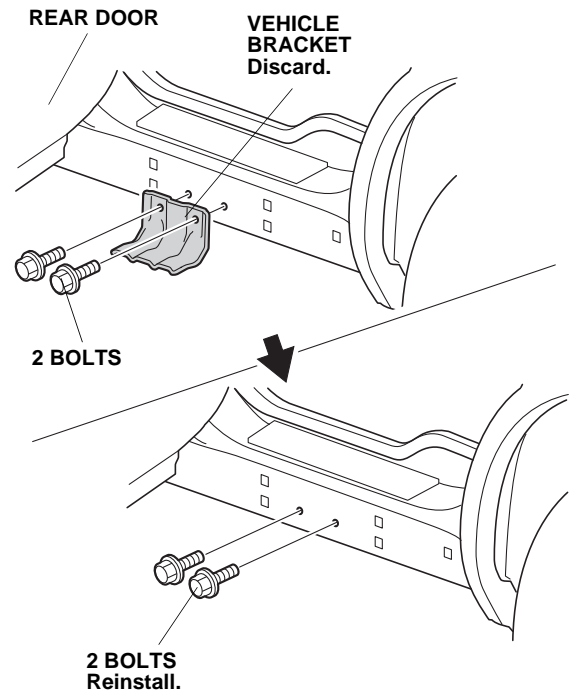

- Align the front clip and 11 side clips with the holes in the body, then push on the new left side sill panel until the side clips snap into place.

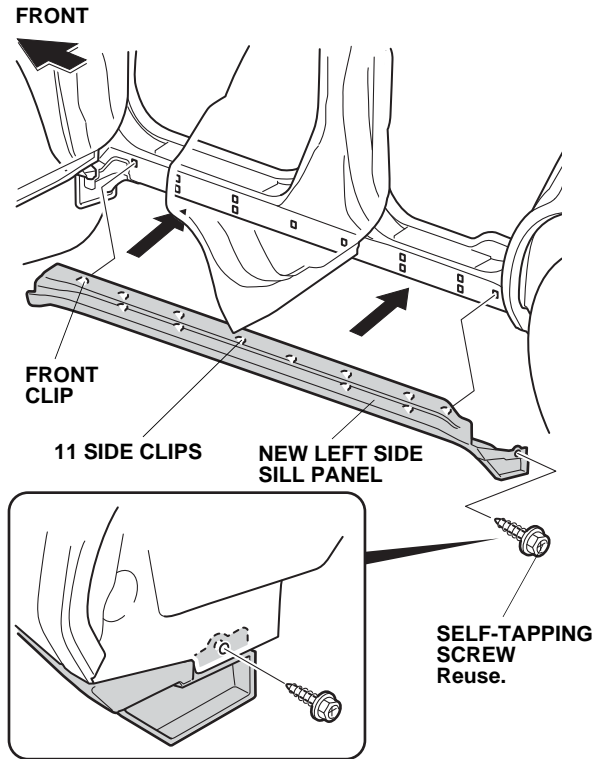

- Secure the rear portion of the new left side sill panel with the self-tapping screw removed in step 3. Close both doors.

- Install the new left front splash guard with the five self-tapping screws removed in step 1. Do not tighten the self-tapping screws yet.

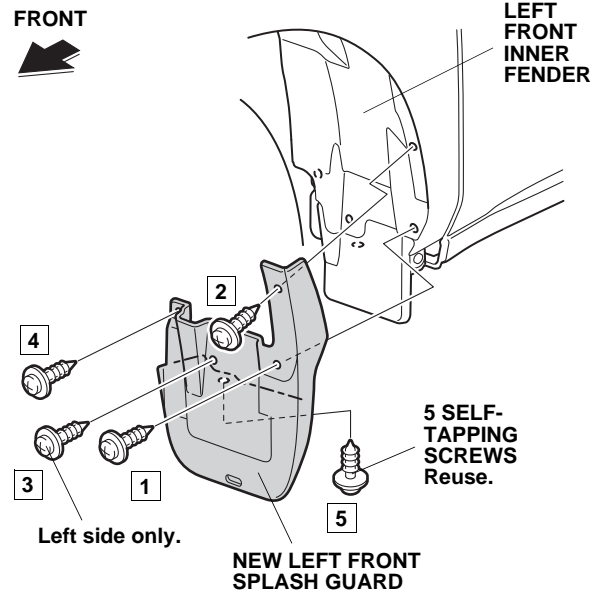

- While holding the new left front splash guard against the left front inner fender, tighten the self-tapping screws in the order shown. (The right front splash guard uses only four self-tapping screws.)

13. Position left bracket A on the vehicle frame. Install left bracket A to the vehicle frame with two flange bolts. Do not tighten the flange bolts yet. Make sure the flange bolts are installed in the correct positions.
- NOTE: If there is undercoat on the body surface where the brackets will attach, use a scraper to remove the undercoat before installing the brackets. If necessary, clean the threads using a tap. Take care not to damage the paint finish.

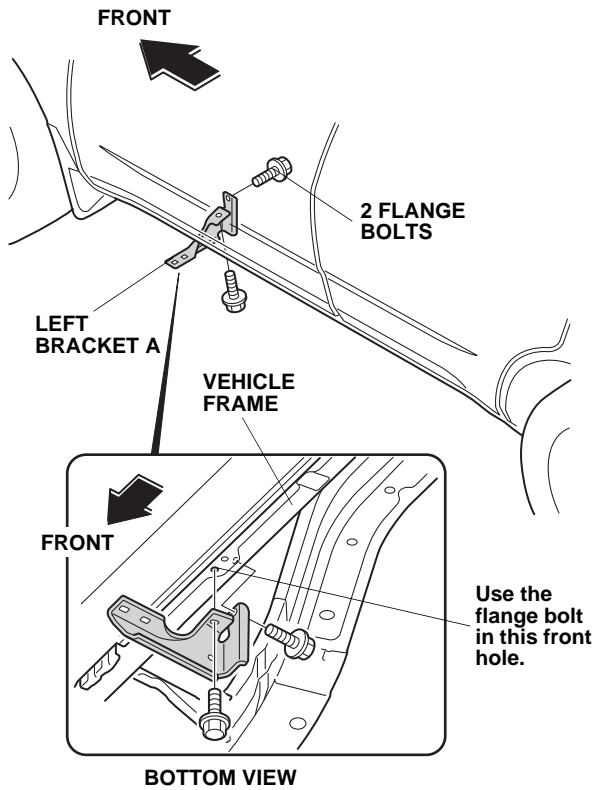

14. Position two left brackets B on the vehicle frame. Install two left brackets B on the vehicle frame with two flange bolts for each. Do not tighten the flange bolts yet. Make sure the flange bolts are installed in the correct positions.
- NOTE: If there is undercoat on the body surface where the brackets will attach, use a scraper to remove the undercoat before installing the brackets. If necessary, clean the threads using a tap. Take care not to damage the paint finish.

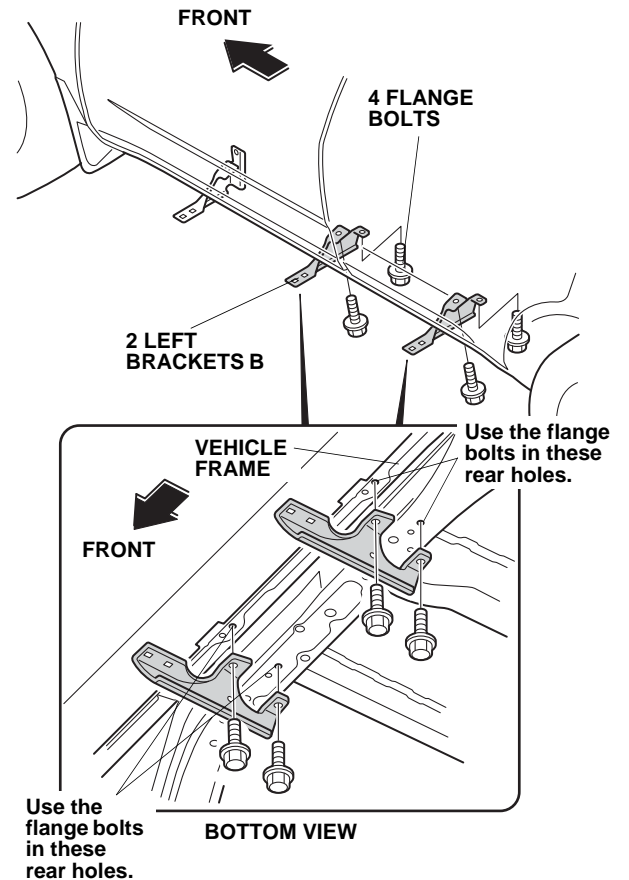

- Slide three square head bolts into each groove on the running board (six total per side).

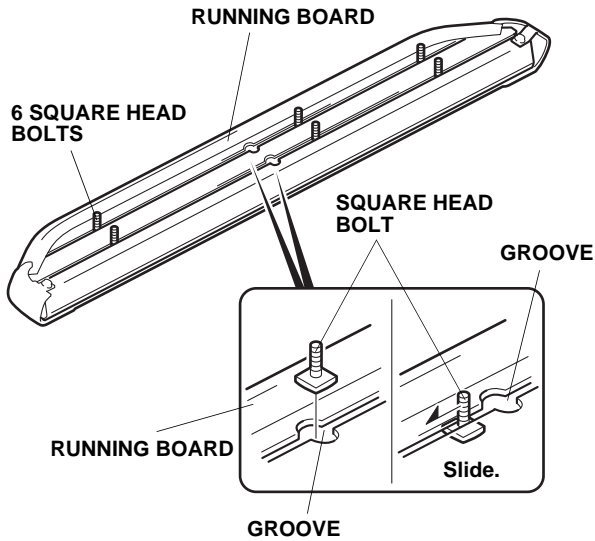

- Align the six running board bolts to the holes in left brackets A and B, and install the running board with six flange nuts. Do not tighten the flange nuts yet.

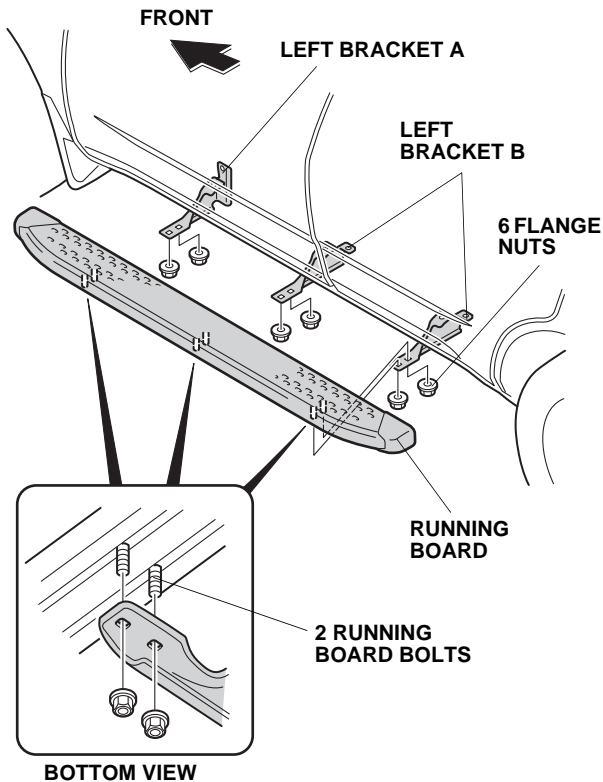

- Center the running board between the front and the rear fenderwells, then torque all the flange bolts and flange nuts to 27 N-m (20 lbf-ft).

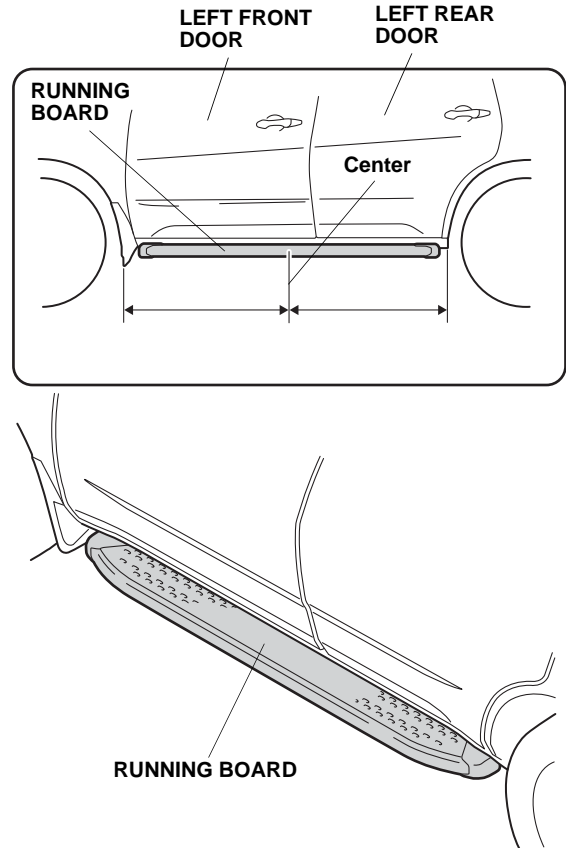

- Turn the steering wheel all the way clockwise, and repeat steps 2 thru 17 to install the running board on the right side of the vehicle.