



INSTALLATION INSTRUCTIONS

Accessory
SIDE UNDER SPOILERS

Application
2013 ILX

Publications No.
BII 13545
Issue Date
MAY 2012

PARTS LIST

Left spoiler

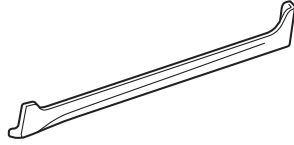

Right spoiler

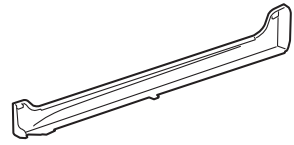

2 Rails



2 Brackets A

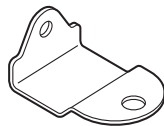

4 Self-tapping screws



2 Bracket screws



4 Flare nuts



2 Clamps

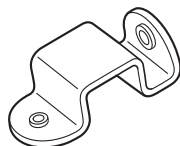

2 Screws



2 Washer-nuts

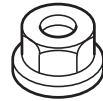

2 Brackets B

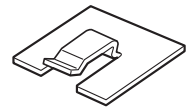

Template A

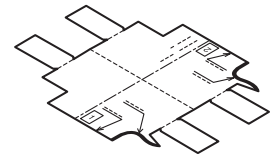

Template B

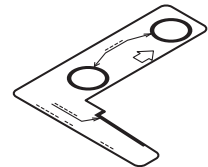

2 Clips

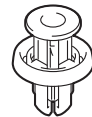

TOOL AND SUPPLIES REQUIRED

Phillips screwdriver
Isopropyl alcohol
Shop towel
Masking tape
Scissors
Ruler
Tape measure
Soap
Ratchet
10 mm Socket
Torque wrench
10 mm Open end wrench
Felt-tip pen
Utility knife
Touch-up paint

The following tool is available through the Honda Tool and Equipment Program. On the iN, click on: Service > Service Bay > Tool and Equipment Program, then enter the number under "Search". Or, call 888-424-6857.

Rubber Roller (T/N MHLE54D)

INSTALLATION

Client Information: The information in this installation instruction is intended for use only by skilled technicians who have the proper tools, equipment, and training to correctly and safely add equipment to your vehicle. These procedures should not be attempted by "do-it-yourselfers."

NOTE:

- These installation instructions show the left spoiler being installed. The same procedure applies to installing the right spoiler.
- Be careful not to damage the paint finish.
- Thoroughly clean the bottom of the body from the rear of the front wheels to the front of the rear wheels.
- This side under spoilers kit should be installed only if the ambient air temperature is 15°C (60°F) or above.
- To allow the adhesive to cure, do not wash the vehicle for 24 hours. Please advise the client.

1. Using a felt-tip pen, mark the vehicle panel at the measurements shown.

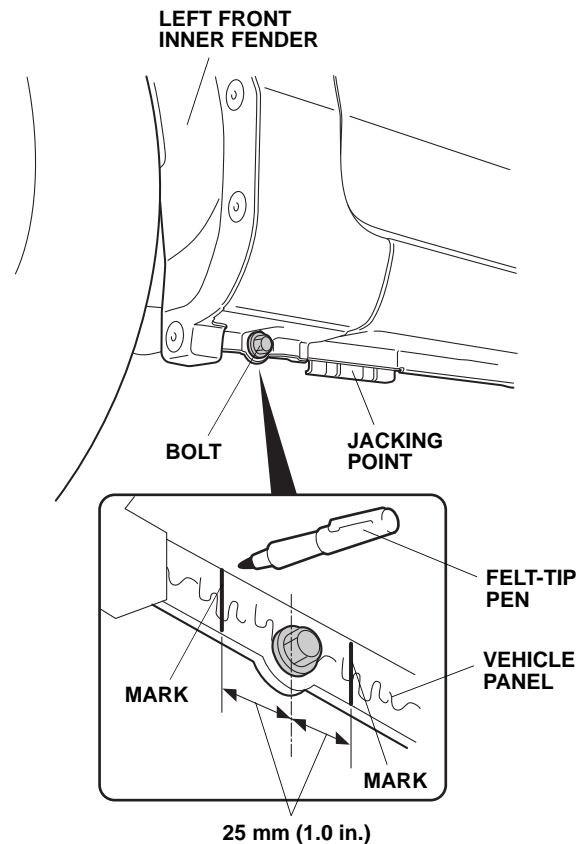

2. Remove the bolt from the bottom of the left front fender.

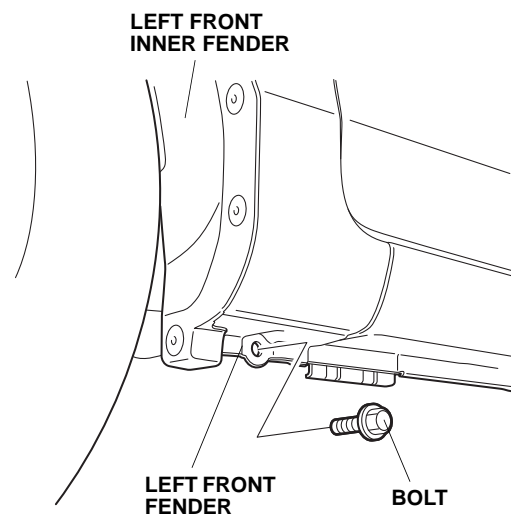

- Using a utility knife, remove the undercoating in the area shown.

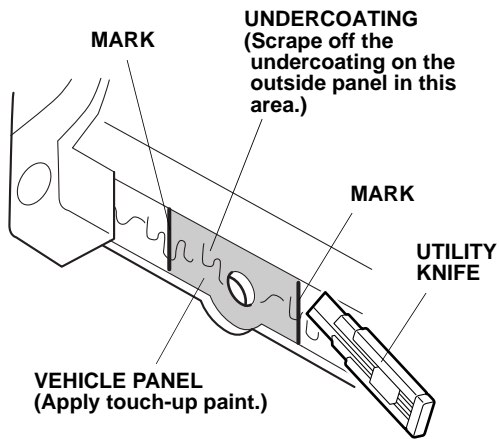

- Apply touch-up paint to the area where you removed the undercoating, and allow it to dry thoroughly.
- Using a felt-tip, mark the left rear fenderwell at the measurements shown.

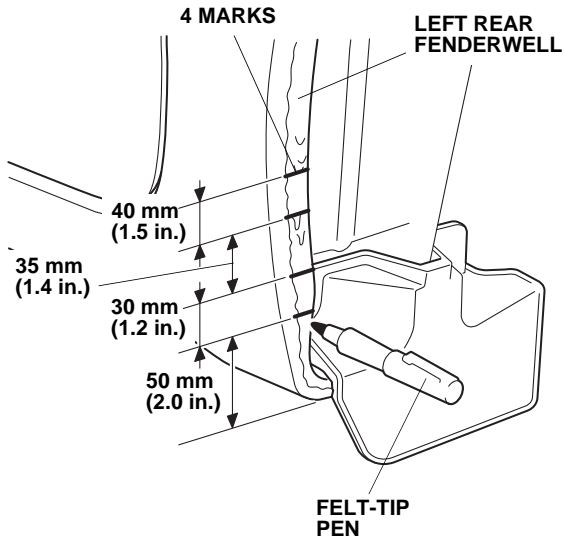

- Using a utility knife, remove the undercoating in the areas shown.

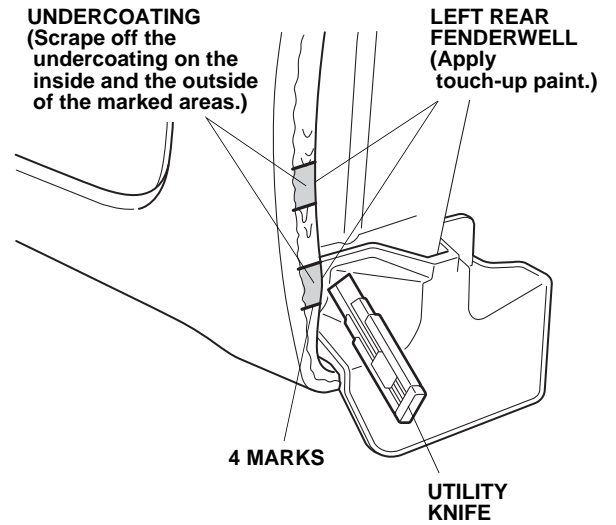

- Apply touch-up paint to the areas where you removed the undercoating, and allow it to dry thoroughly.
- Using isopropyl alcohol on a shop towel, thoroughly clean the left side sill and front fender where the left spoiler will attach.

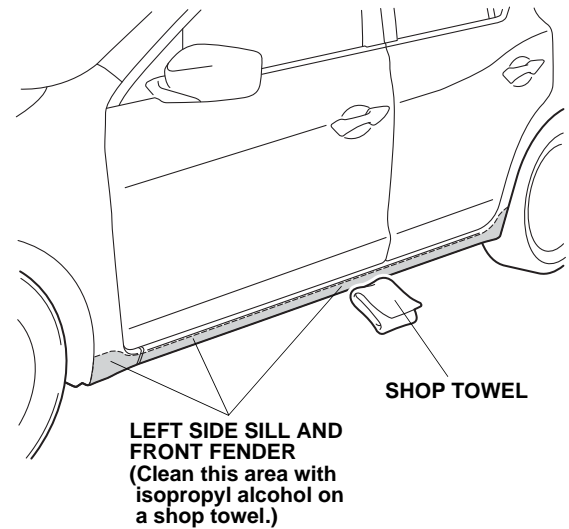

- Align template B with the two clips, and attach it to the left front fender with masking tape.

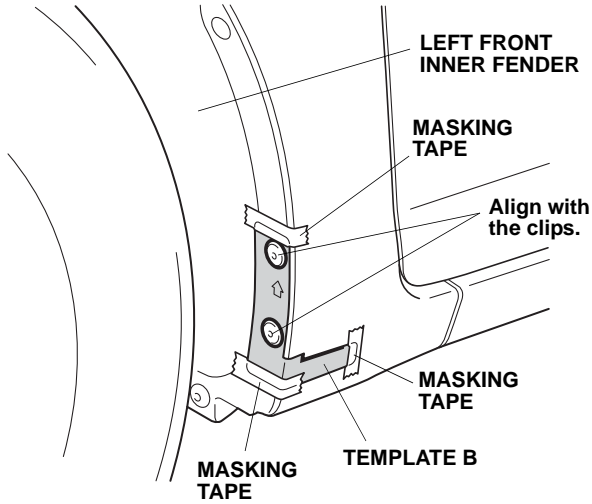

- Using a felt-tip pen, mark the left front fender at the area shown.

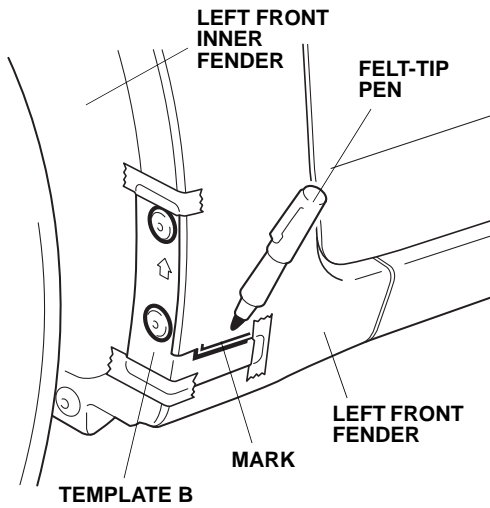

- Carefully remove template B. Do not damage the template, it is needed to mark the right side of the vehicle.

- Remove the adhesive backings from bracket B. Align bracket B with the mark you made, and attach it to the front fender. Press and hold bracket B firmly against the fender for 30 seconds.

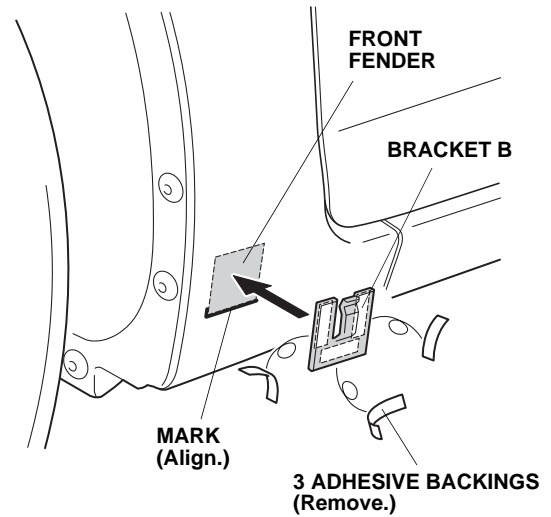

- Using scissors, cut template A in half to create two templates. The templates are marked 1 and 2.

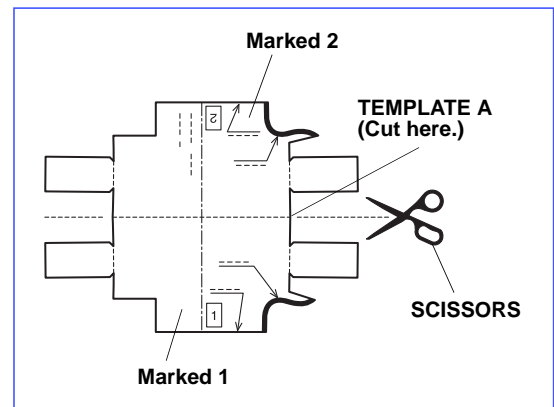

14. Fold each template as shown (Template 1 is used to mark the front of the side sill, and template 2 is used to mark the rear of the side sill.).

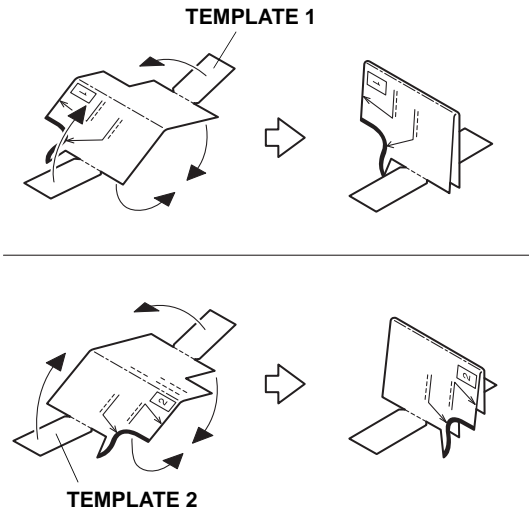

15. Insert the tab on template 1 into the gap between the left front door and the side sill at the measurement shown. With the template flush against the side sill, tape the template to the door. There should be no gap between the template and the side sill.

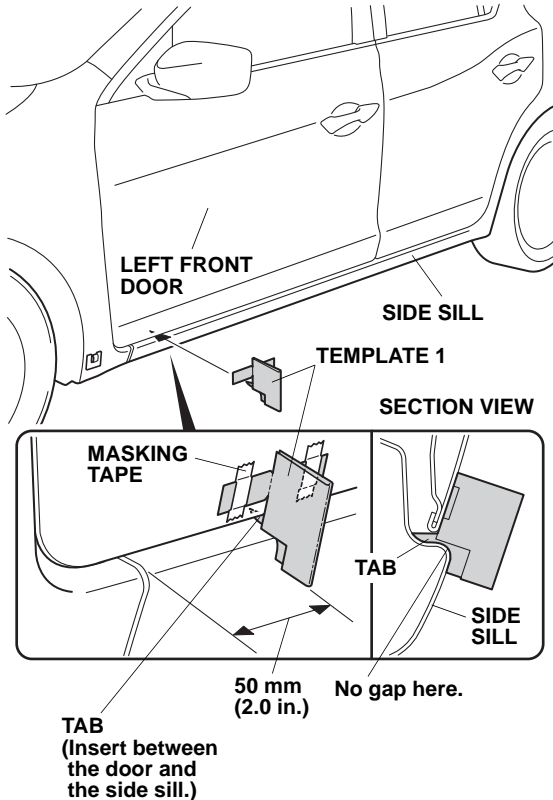

16. Insert the tab on template 2 into the gap between the left rear door and the side sill at the measurement shown. With the template flush against the side sill, tape the template to the door. There should be no gap between the template and the side sill.

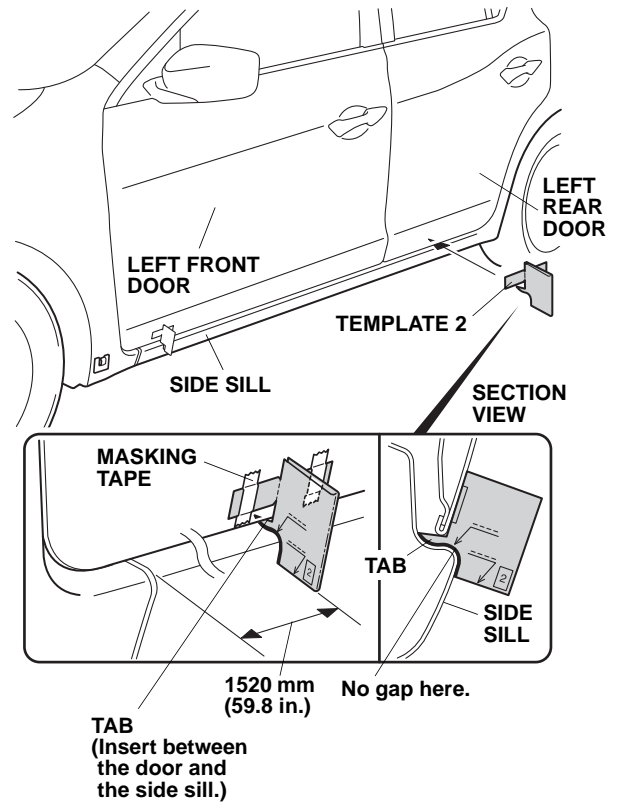

17. Using a utility knife, cut the adhesive backing in half on the rail.

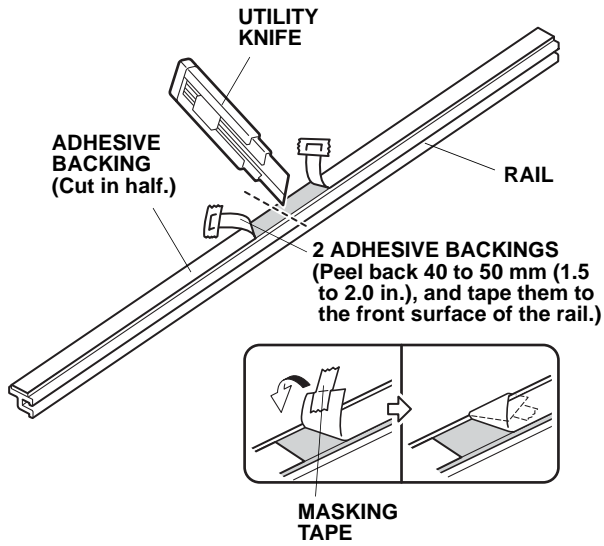

18. Peel back about 40 to 50 mm (1.5 to 2.0 in.) of adhesive backing from each adhesive strip, and tape the ends to the front surface of the rail.
19. With the help of an assistant to hold each template firmly in place, align the front edge of the rail with template 1. Align the top edge of the rail against the bottom of each template, and attach the rail to the side sill.

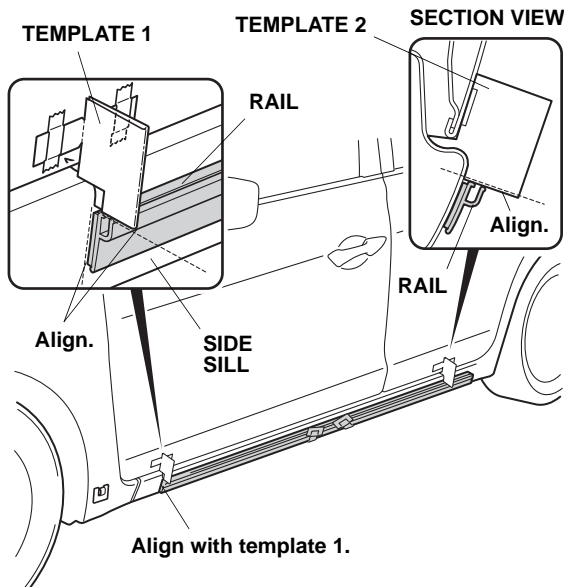

20. While holding the rail in place, slowly and carefully remove each adhesive backing.

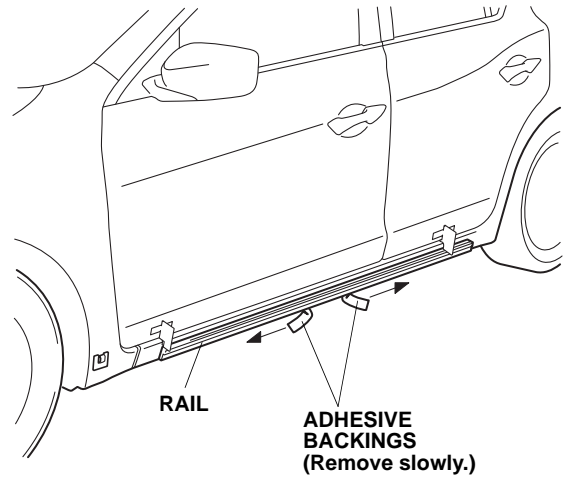

21. Remove both templates. Be careful not to damage the templates, they will be reused on the right side of the vehicle.

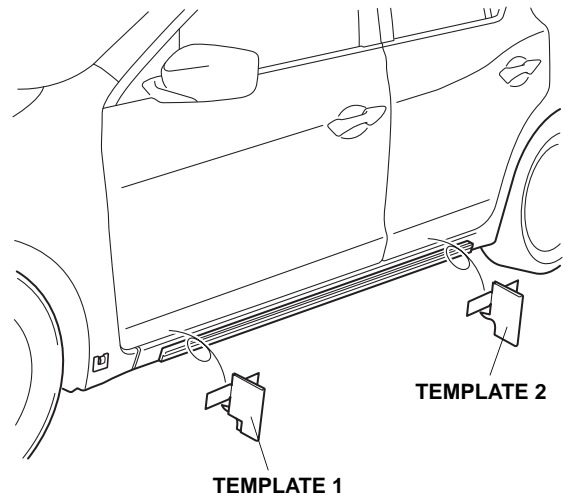

22. Using the palm of your hand, firmly press the rail against the side sill for 30 seconds. Then use a rubber roller to set the adhesive.

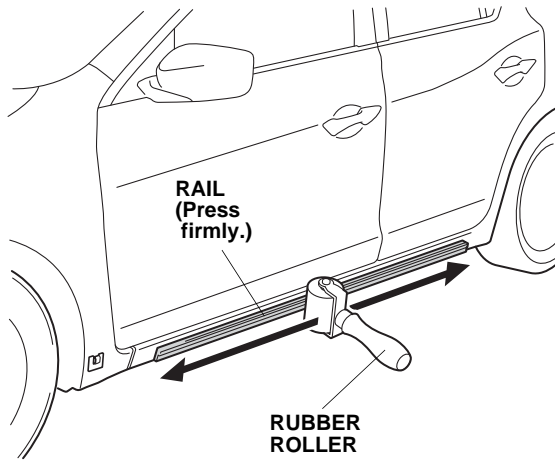

23. Secure a bracket A to the left front fender using the bolt removed in step 2. Torque the bolt to 10 N·m (7.5 lbf·ft).

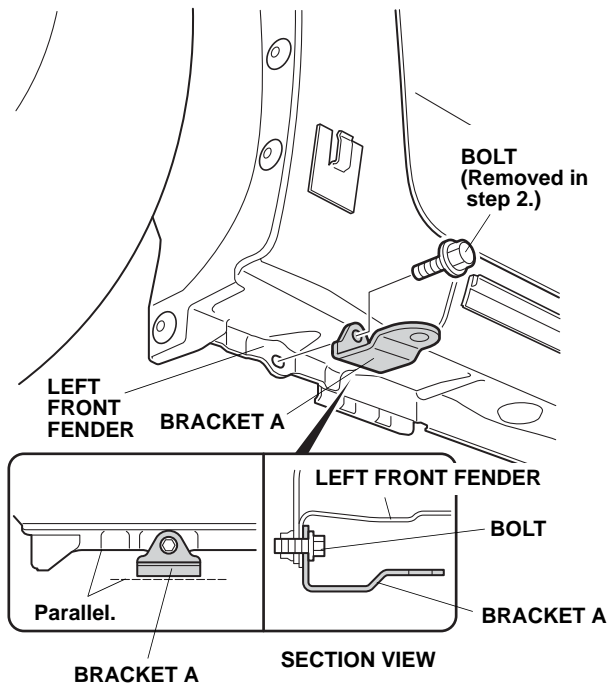

24. Wash your hands with soap and water, and leave a small amount of soap on your fingers. Apply the soapy water to the gasket on the left spoiler. **NOTE:** Do not use organic solvent (e.g. thinner, benzene, gasoline, etc.) or an acid or alkaline solution.

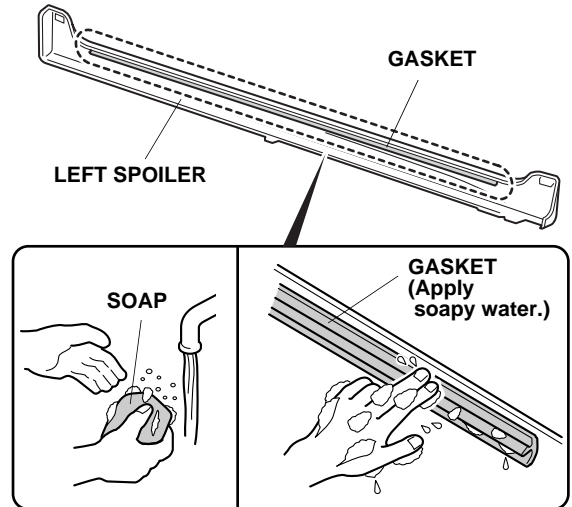

25. Remove the adhesive backing from the left spoiler.

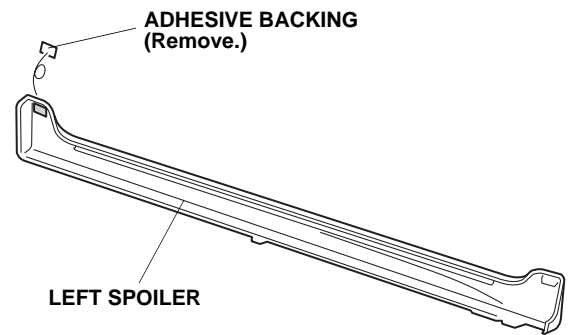

26. Insert the bracket on the spoiler into bracket B, and align the gasket on the left spoiler with the rail. Insert the front end of the gasket into the rail first, then work rearward. Move the left spoiler gently up and down, while checking that the gasket is installed securely in the rail.

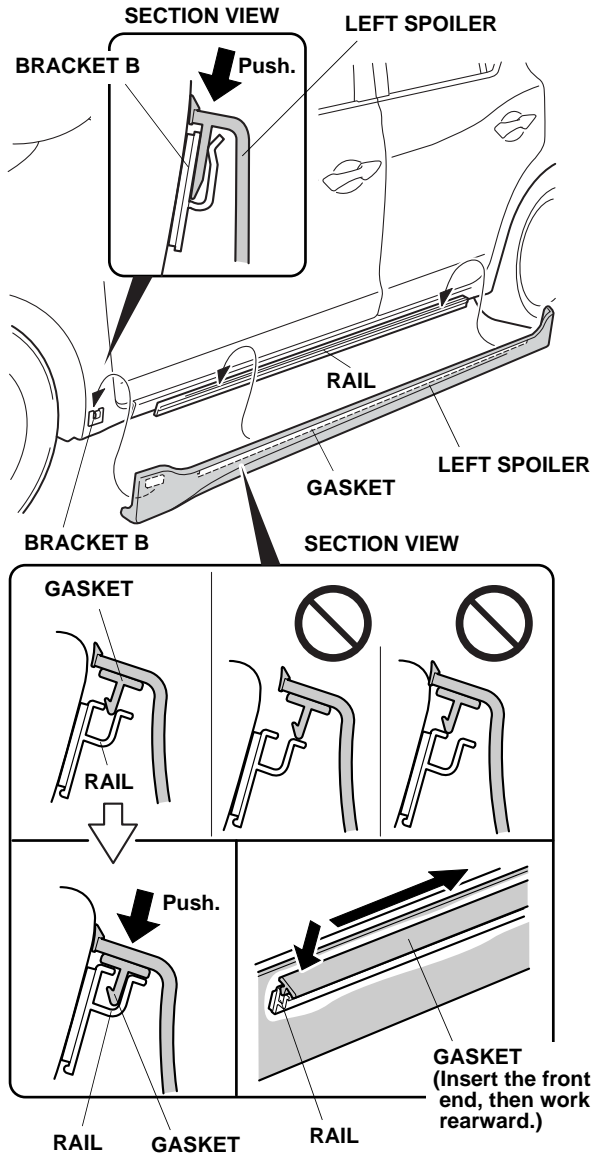

27. Lightly tap the left spoiler to remove any gap between the left spoiler and the left rear fenderwell.

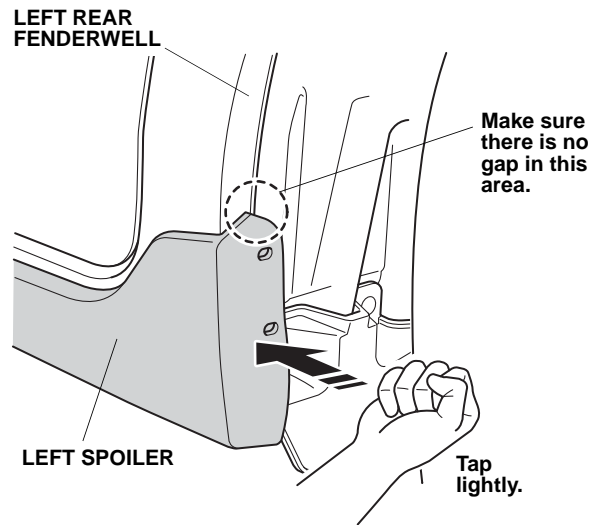

28. Install two flare nuts on the rear fender lip. Loosely install two self-tapping screws. Make sure to install the flare nuts in the correct position and orientation.

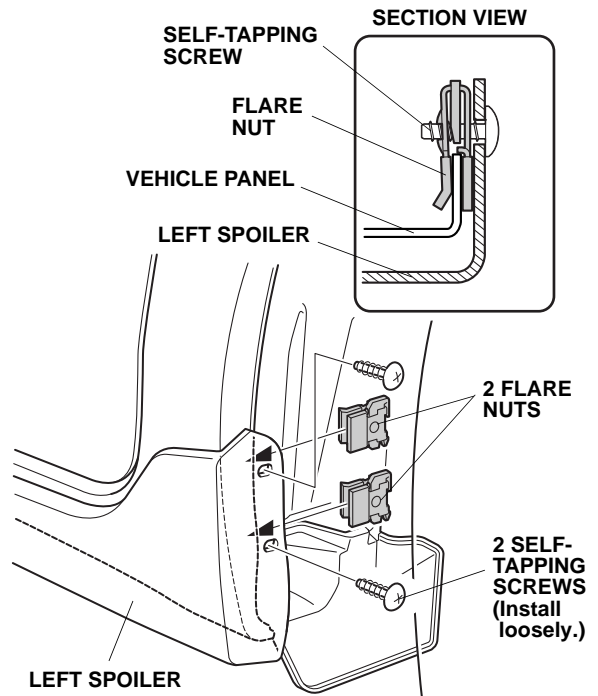

29. Secure the left spoiler to bracket A with one clip.

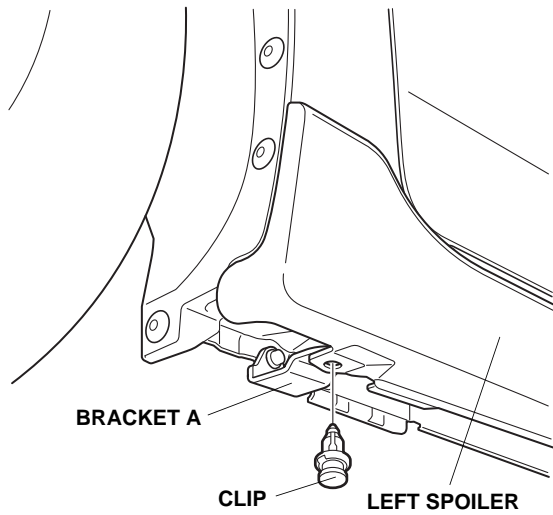

30. Install the clamp to the left spoiler using a bracket screw.

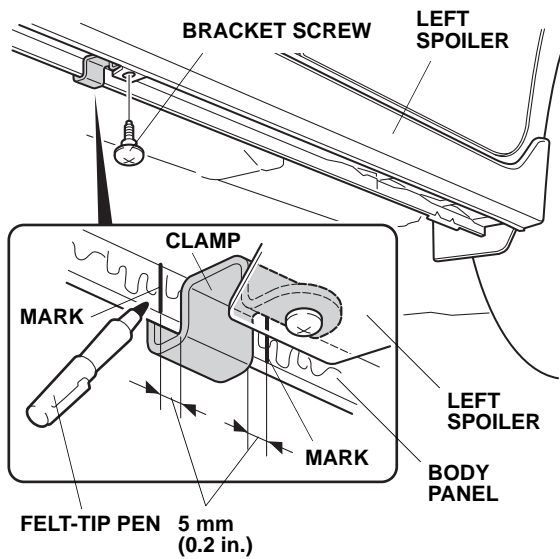

31. Using a felt-tip pen, mark the body panel at the measurements shown.
 32. Remove the clamp and bracket screw.

33. Using a utility knife, remove the undercoating in the area shown.

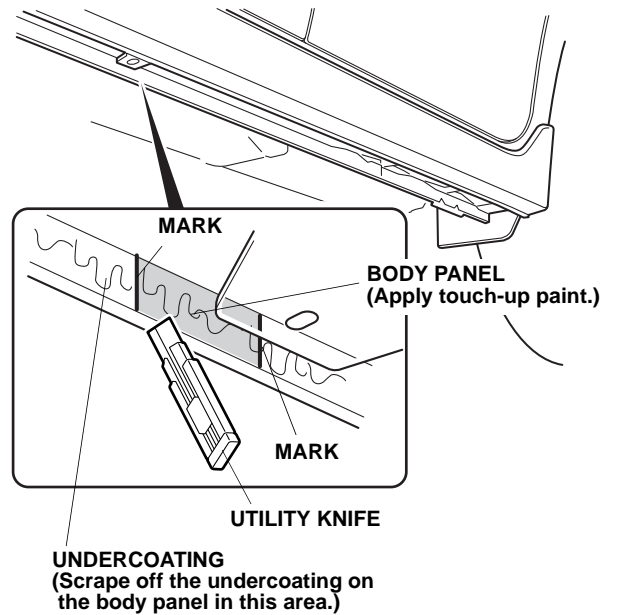

34. Apply touch-up paint to the area where you removed the undercoating, and allow it to dry thoroughly.
 35. Reinstall the clamp. Do not tighten the bracket screw.

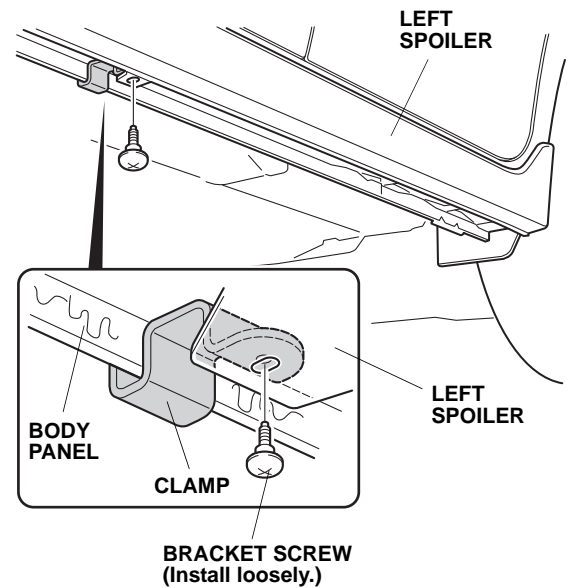

36. Install a washer-nut on a screw as shown.

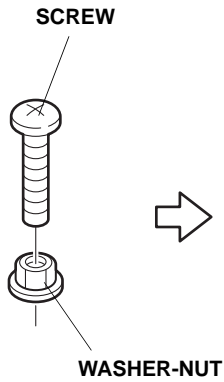

37. Install the screw into the clamp and tighten it securely. Then finger-tighten the washer-nut against the clamp. While holding the screw, tighten the washer-nut.

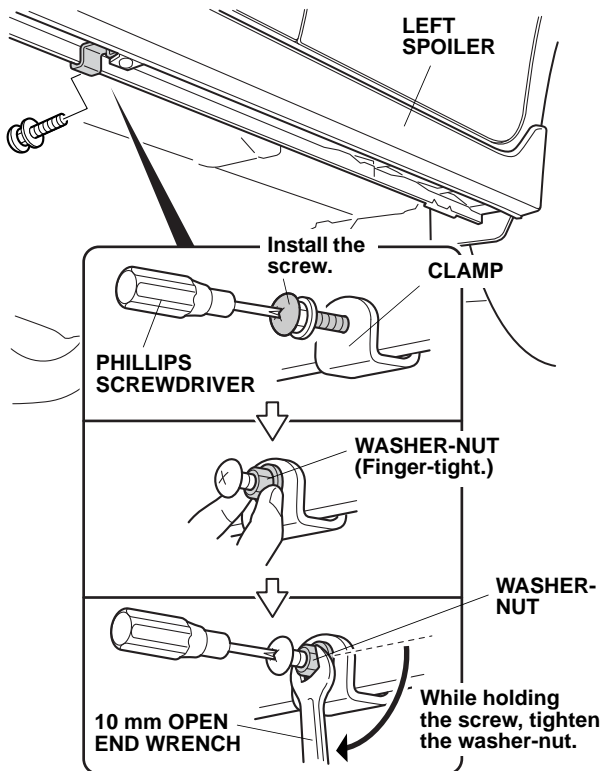

38. Adjust the gap between the spoiler and the body panel.

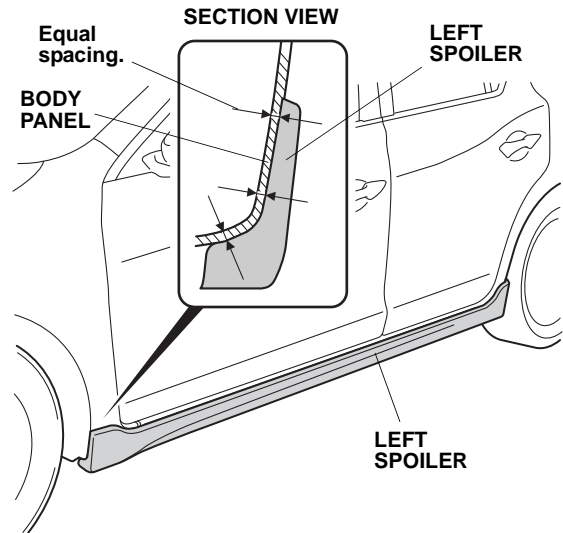

39. At the rear fenderwell, tighten the two self-tapping screws.

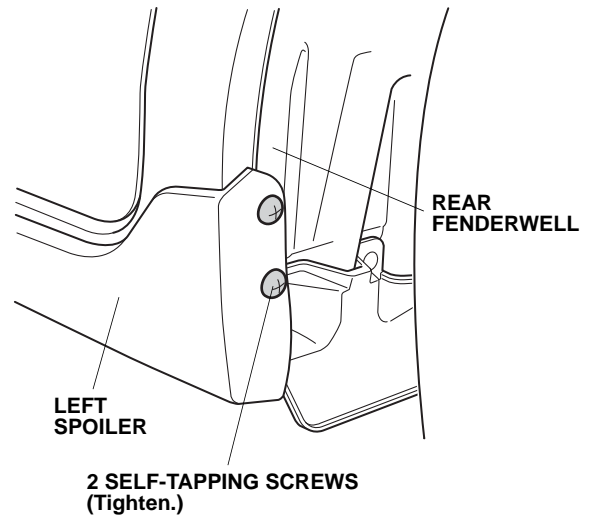

40. Tighten the bracket screw.

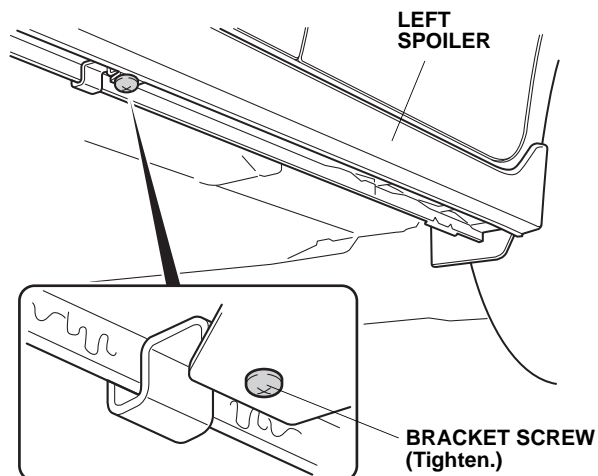

41. Using a rubber roller, apply firm pressure, especially at the ends, to set the adhesive.

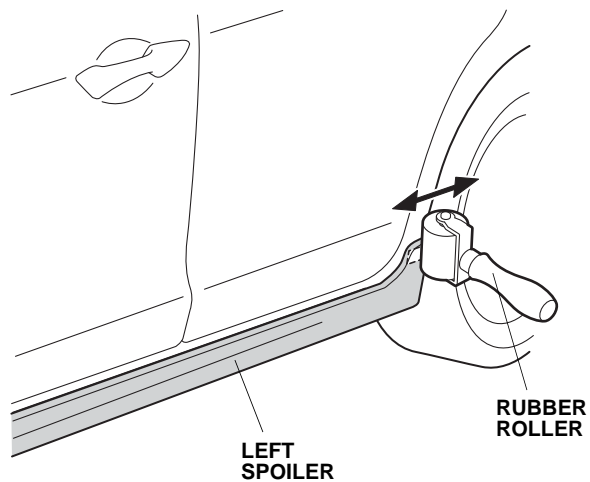

42. Repeat steps 1 through 41 to install the spoiler on the right side of the vehicle.