



# INSTALLATION INSTRUCTIONS

Accessory

BACK-UP SENSORS

Application

2012 TSX

Publications No.

BII 46266

Issue Date

AUG 2011

## PARTS LIST

Back-up Sensors Attachment Kit  
P/N 08V67-TL2-200A

Control unit

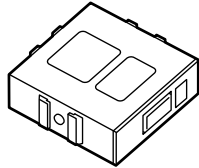

Buzzer

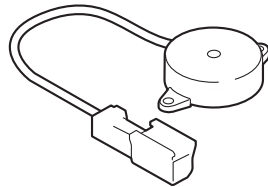

4 Sensor clips

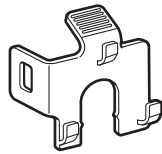

Sensor harness

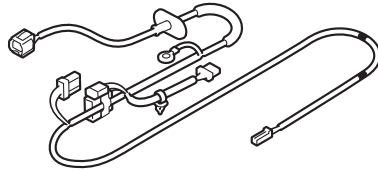

Subharness

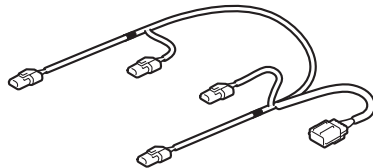

Control unit

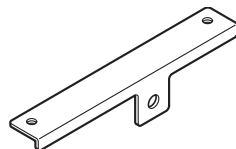

10 Wire ties

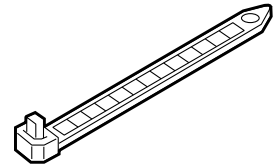

2 Wire ties with clips

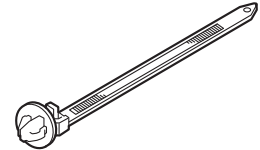

Urethane tape

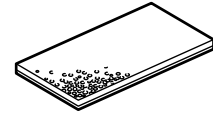

Cushion tape

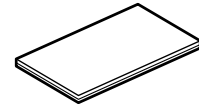

2 Flange bolts



Fuse label

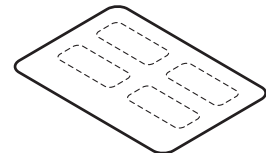

Connector clip



3 Harness tapes



Accessory User's  
Information Manual

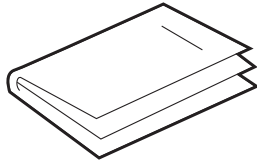

### Back-up Sensors Kit

2 Center sensors

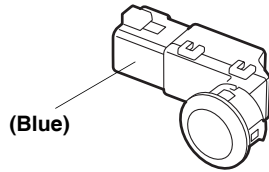

2 Corner sensors

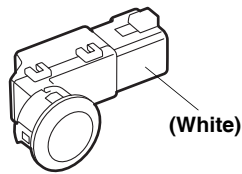

### TOOLS AND SUPPLIES REQUIRED

Phillips screwdriver  
Flat-tip screwdriver  
Small flat-tip screwdriver  
Ratchet  
8 mm and 10 mm Socket  
Tape measure  
Utility knife  
Felt-tip pen  
Pushpin  
Drill  
3 mm Drill bit  
24 mm and 26 mm Hole saw  
Eye protection (safety goggles, face shield, etc.)  
File  
Diagonal cutters  
Isopropyl alcohol  
Shop towel  
Plastic Trim Tool (T/N SILTRIMTL10)  
Blanket

### Illustration of the Back-up Sensors Installed on the Vehicle

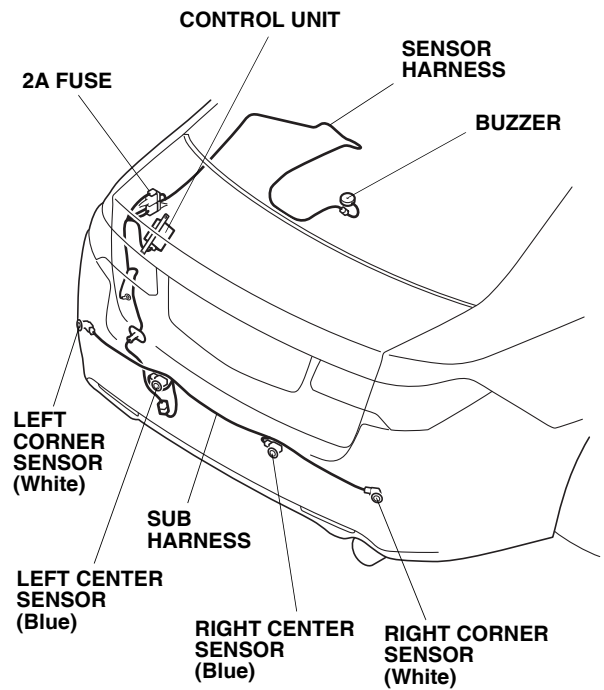

### INSTALLATION

**Client Information:** The information in this installation instruction is intended for use only by skilled technicians who have the proper tools, equipment, and training to correctly and safely add equipment to your vehicle. These procedures should not be attempted by "do-it-yourselfers."

1. Make sure you have the anti-theft code for the audio system or the navigation system (if equipped), then write down the radio presets.
2. Disconnect the negative cable from the battery.

- Open the trunk lid. Remove the two caps and two bolts from the rear bumper.

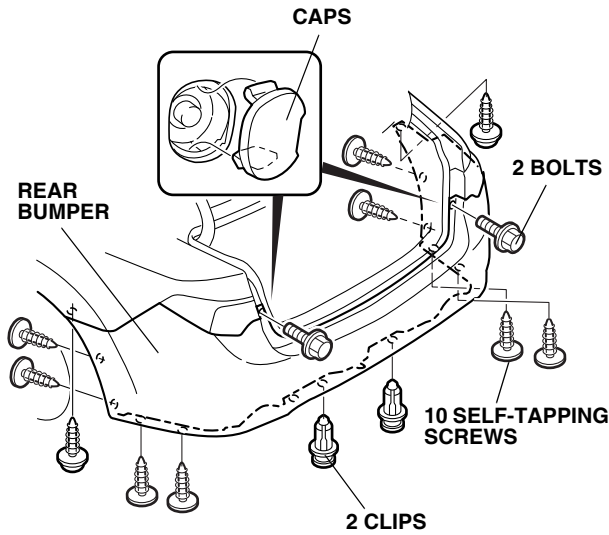

- Remove the rear bumper (two clips and ten self-tapping screws).
  - Have an assistant help you when removing and installing the rear bumper.
  - Place the rear bumper on a blanket to prevent damage.

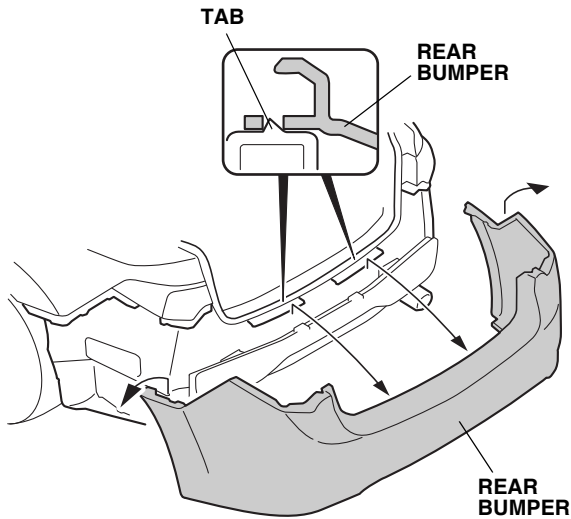

- Pull the left and right rear seatback lock openers to tilt the left and right rear seatbacks forward.

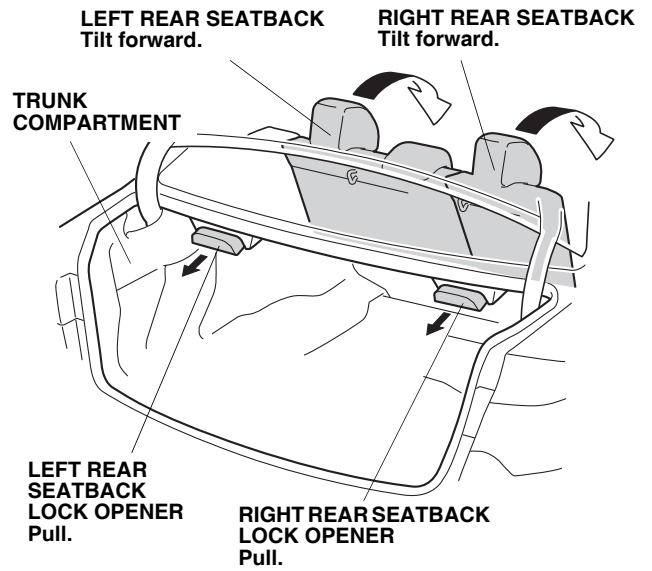

- Remove the spare tire lid (two clips).

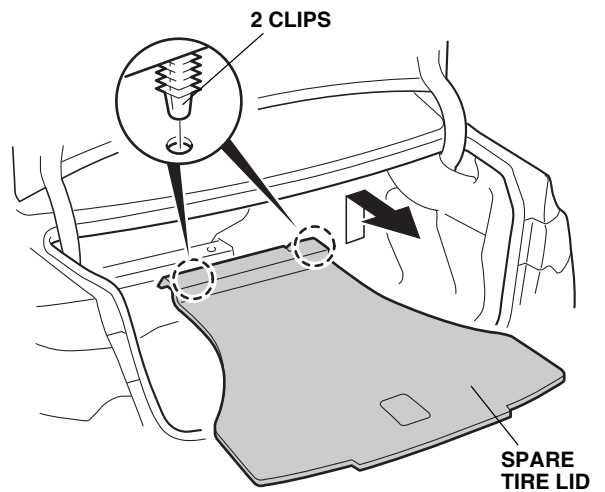

7. Pull away the weatherstrip, and remove the rear trim panel (five clips and two hooks).

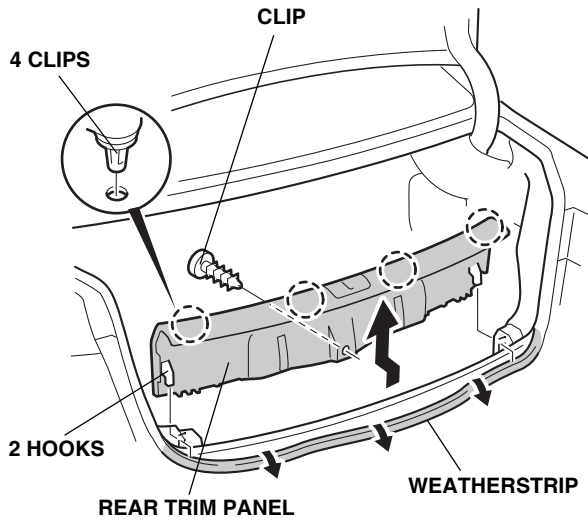

8. Pull away the weatherstrip, and remove the trunk left side trim panel (five clips and two hooks).

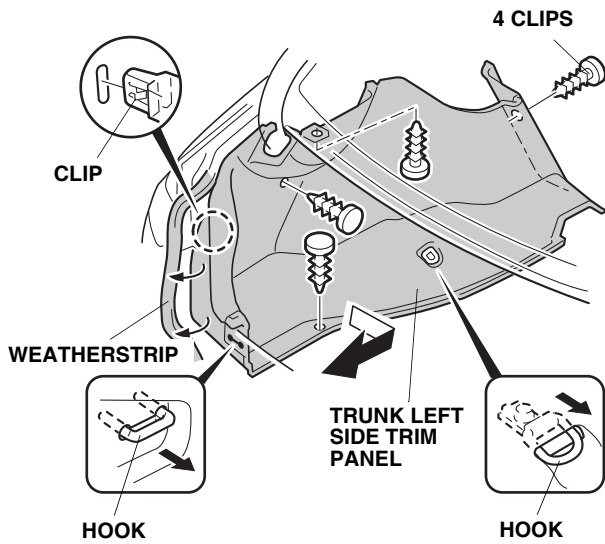

9. Attach the 2A rear sensor fuse label to the sensor harness fuse case.

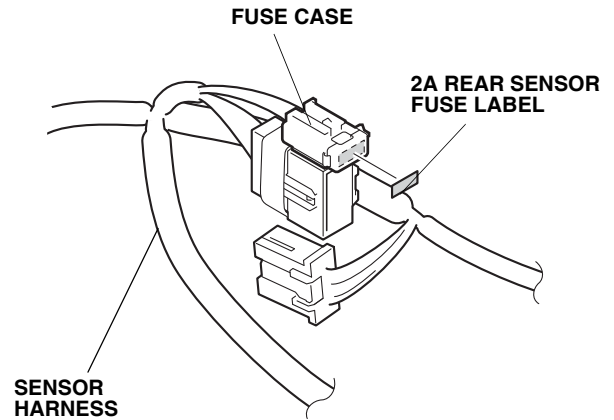

10. Route the sensor harness 14-pin connector through the vehicle panel as shown.

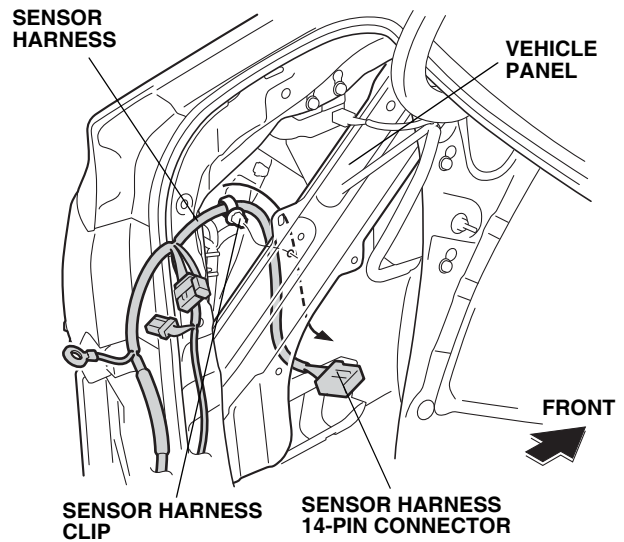

11. Secure the sensor harness clip to the vehicle panel.

12. Insert the control unit bracket into the control unit.

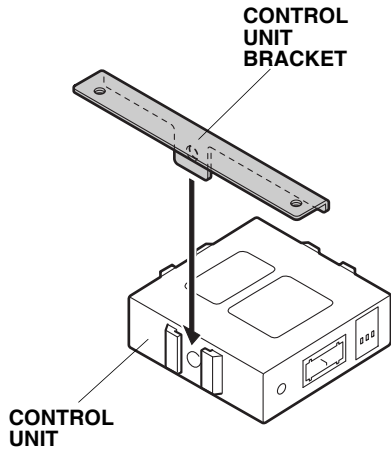

13. Plug the sensor harness 14-pin connector into the control unit.

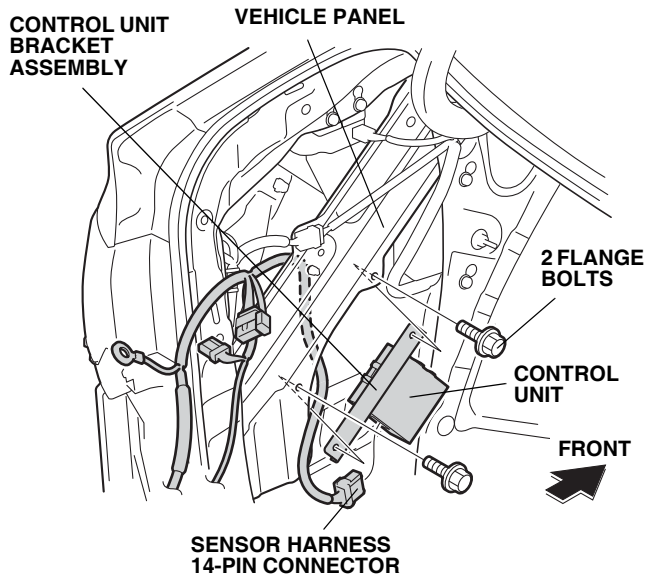

14. Install the control unit bracket assembly on the vehicle panel using two flange bolts.

15. Disconnect the vehicle 20-pin connector. Plug the sensor harness 20-pin connector into the vehicle 20-pin connector. Plug the vehicle 20-pin connector you just disconnected into the sensor harness 20-pin connector.

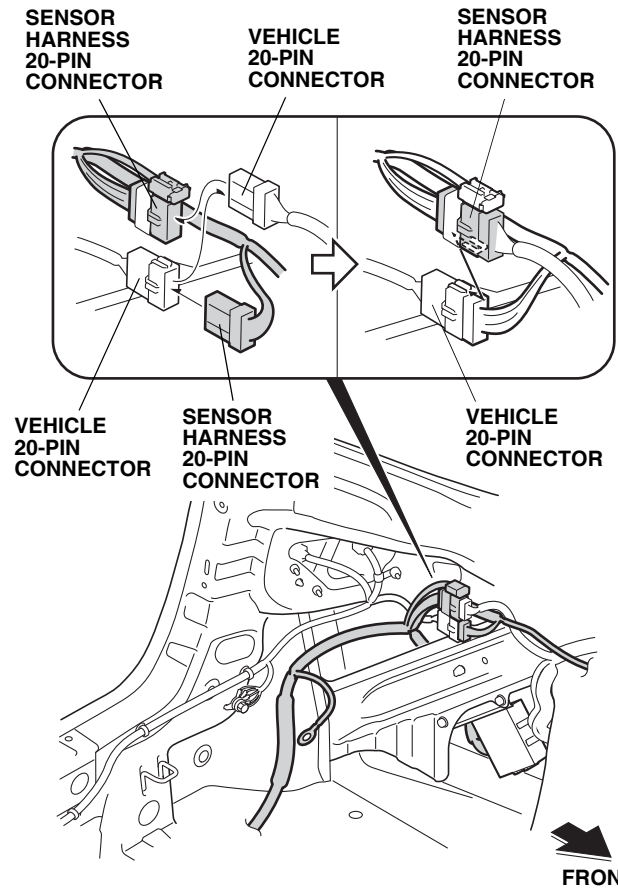

16. Attach the sensor harness 20-pin connector onto the vehicle 20-pin connector as shown.

- Using isopropyl alcohol on a shop towel, clean the area where the buzzer will attach.

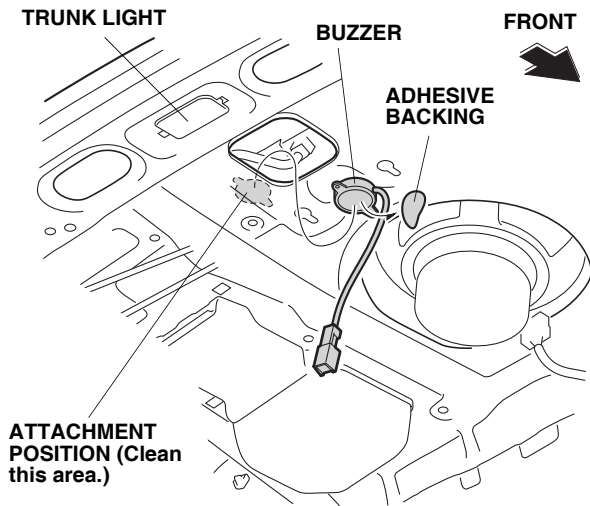

- Remove the adhesive backing from the buzzer, and attach the buzzer at the indicated position.
- Route the sensor harness through the hole in the vehicle panel as shown.

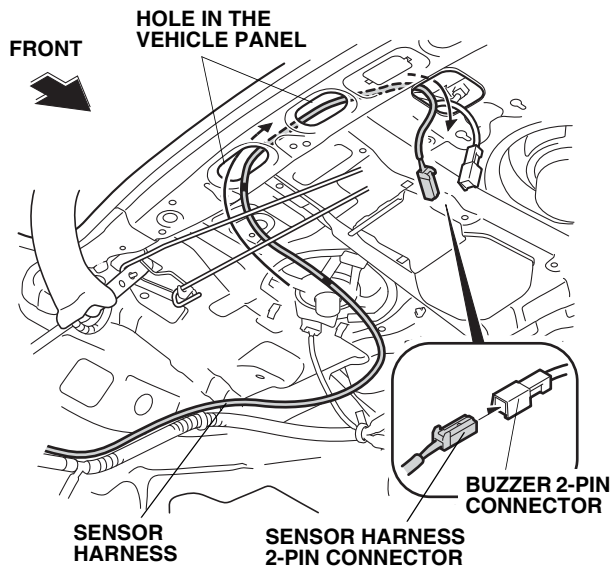

- Plug the sensor harness 2-pin connector into the buzzer 2-pin connector.

- Install a wire tie with clip to the sensor harness at each taped mark.

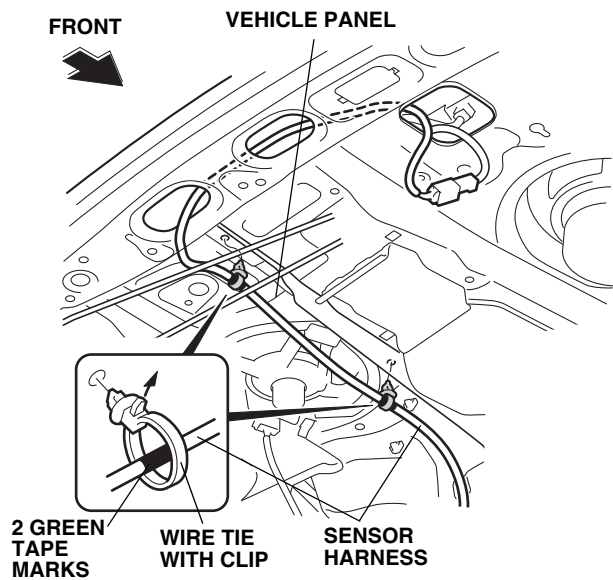

- Secure the sensor harness to the vehicle panel using two wire ties with clips you just installed.
- Using isopropyl alcohol on a shop towel, clean the area where the cushion tape will attach.

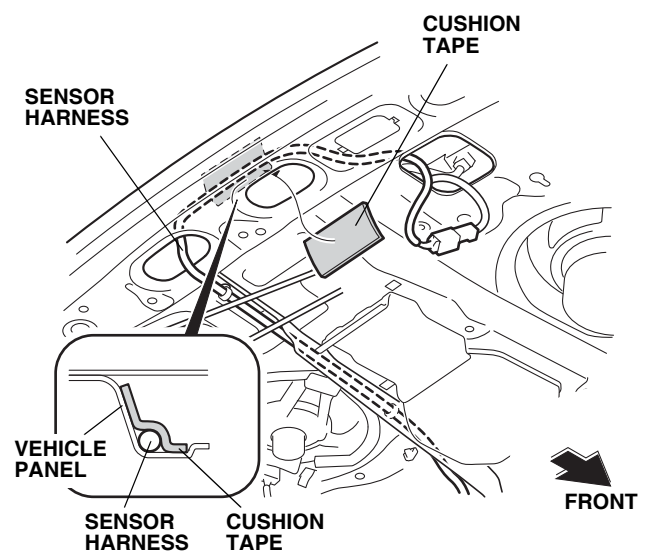

- Secure the sensor harness to the vehicle panel using one cushion tape.

25. Bundle up the excess buzzer harness and secure it to the vehicle harness with one urethane tape.

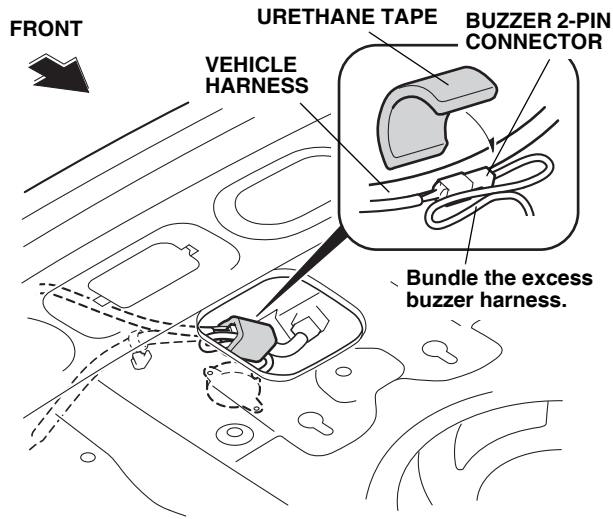

26. Secure the sensor harness to the vehicle harness using six wire ties.

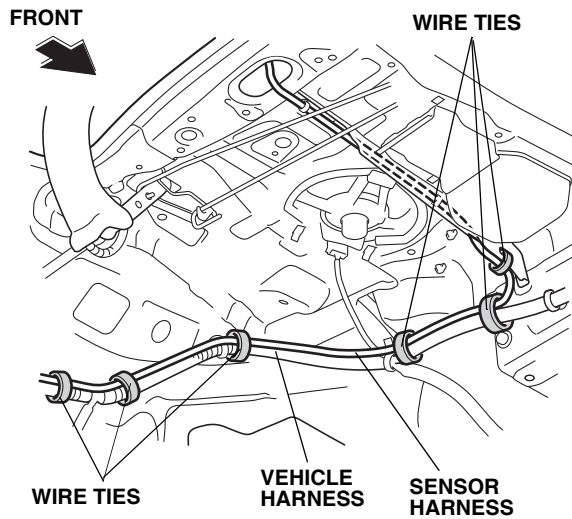

27. Remove the vehicle bolt from the vehicle ground terminal.

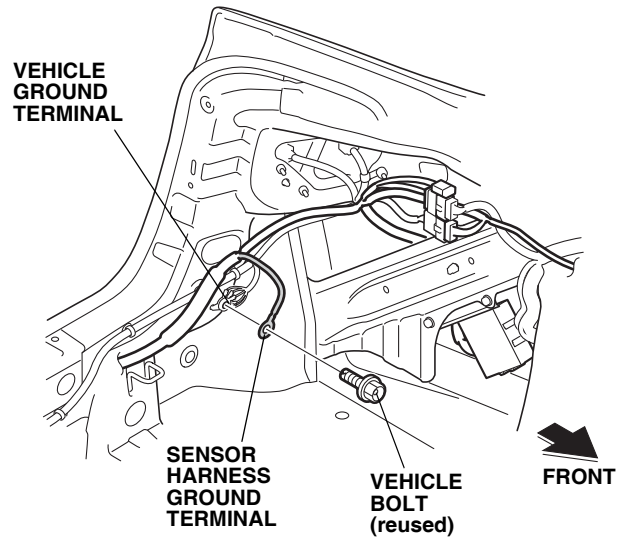

28. Attach the sensor harness ground terminal to the vehicle ground terminal, and reinstall the vehicle bolt.

29. Remove and discard the vehicle grommet.

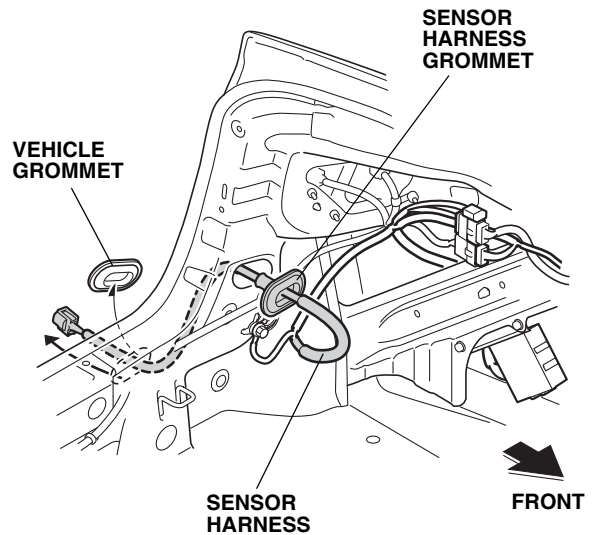

30. Route the sensor harness through the inside vehicle panel and pull the sensor harness grommet out of the grommet hole.

31. Turn the triangle mark on the sensor harness grommet so it points up, and install the grommet into the vehicle panel as shown.

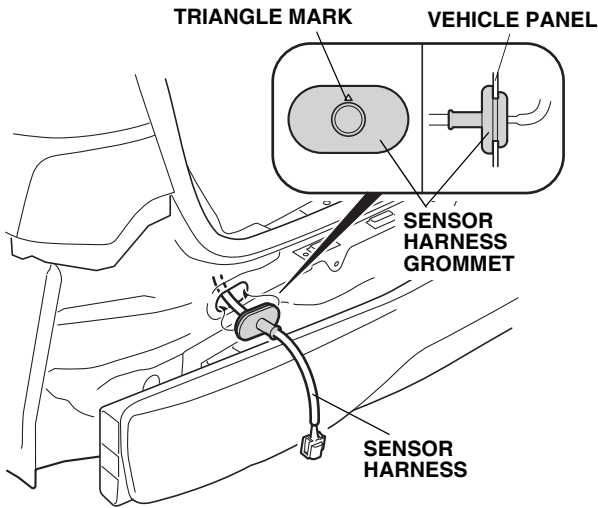

32. Secure the sensor harness to the vehicle harness using two wire ties.

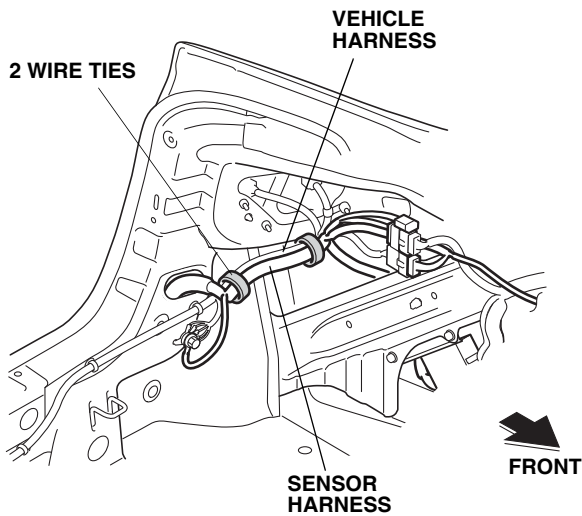

33. Install the connector clip to the sensor harness 8-pin connector, and secure the connector clip to the vehicle panel.

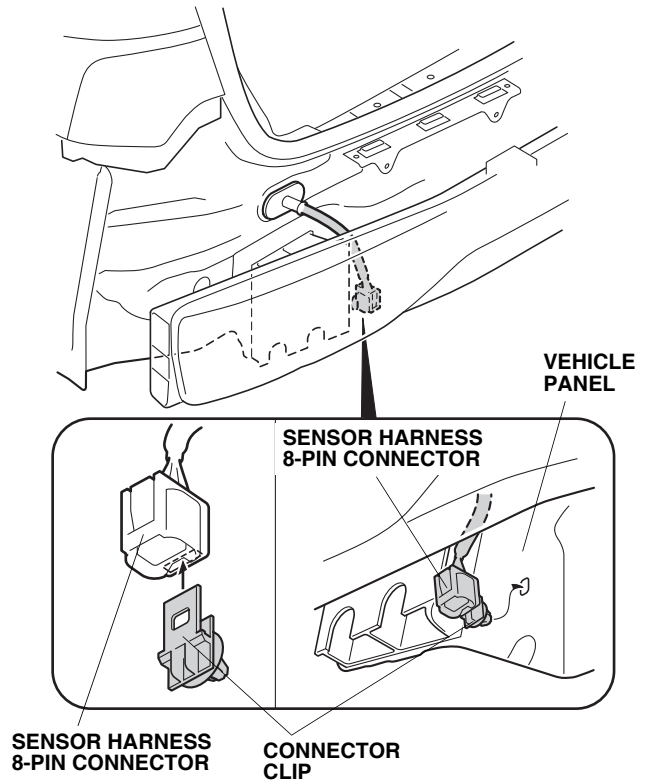

34. Remove the rear bumper absorber from the rear bumper beam.

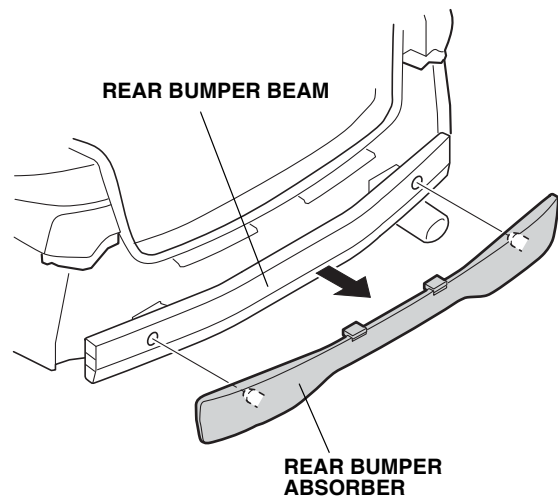



35. Using a utility knife, cut the rear bumper absorber at the measurements shown.

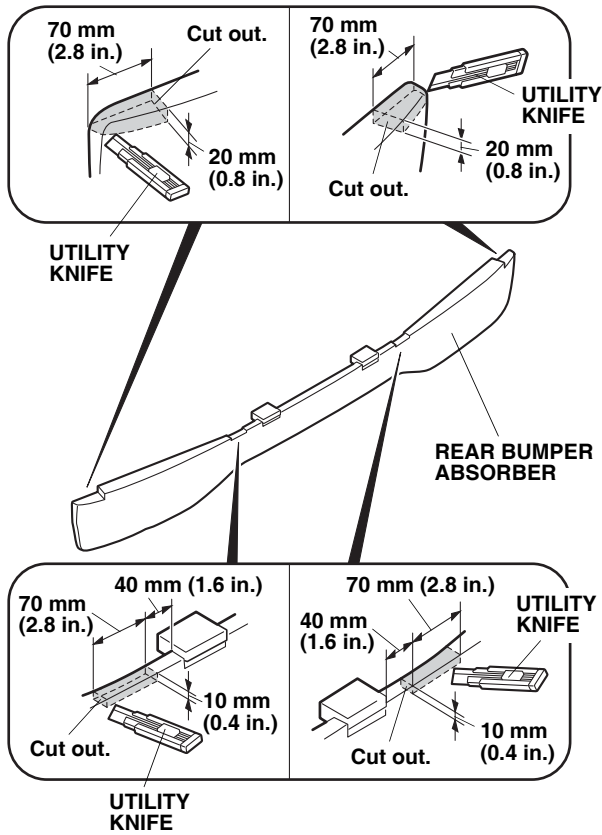

36. Reinstall the rear bumper absorber.

**If the vehicle is equipped with an Aero Bumper, go to step 46. If not, continue with step 37.**

37. Mark the rear bumper:

- On the inside of the bumper, locate the four back-up sensor preset marks. Make sure the marks look like the marks in the illustration below.
- Using a grease pencil, highlight the four preset marks.

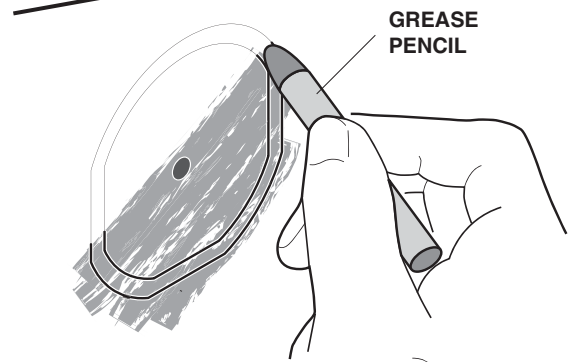
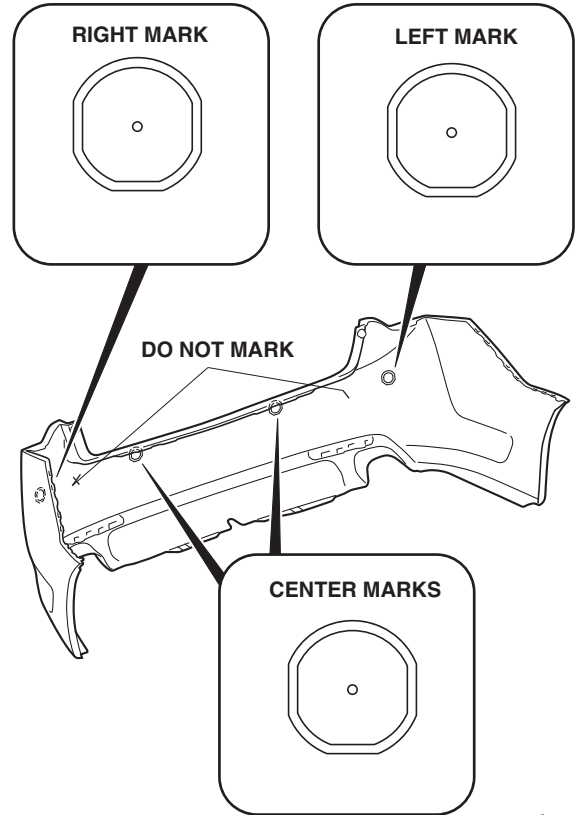

- Locate the center mark protruding from the bumper at each of the four preset marks.
- Using a pushpin, pierce the bumper at all four identified marks.

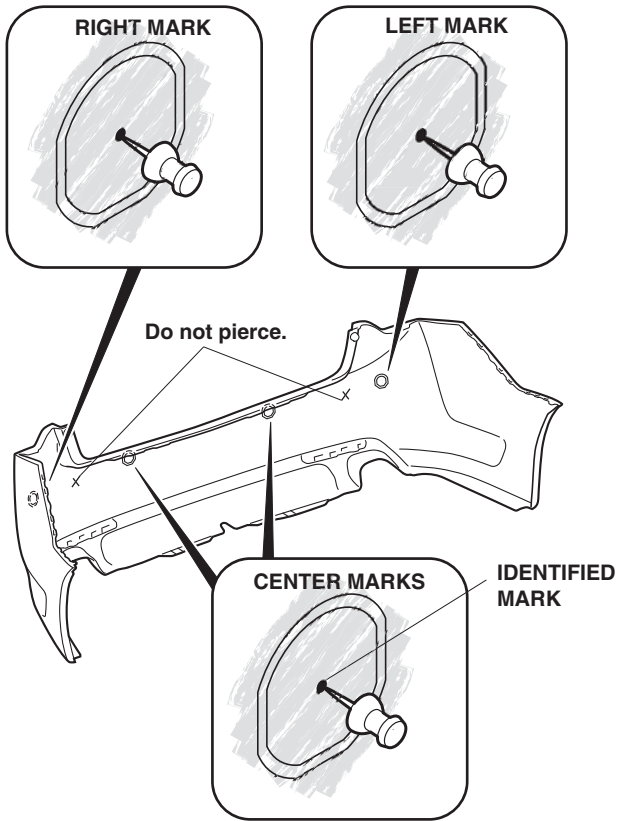

- On the left side of the bumper, use a straight edge to measure 12 mm **upward** from the center mark, and pierce the bumper.

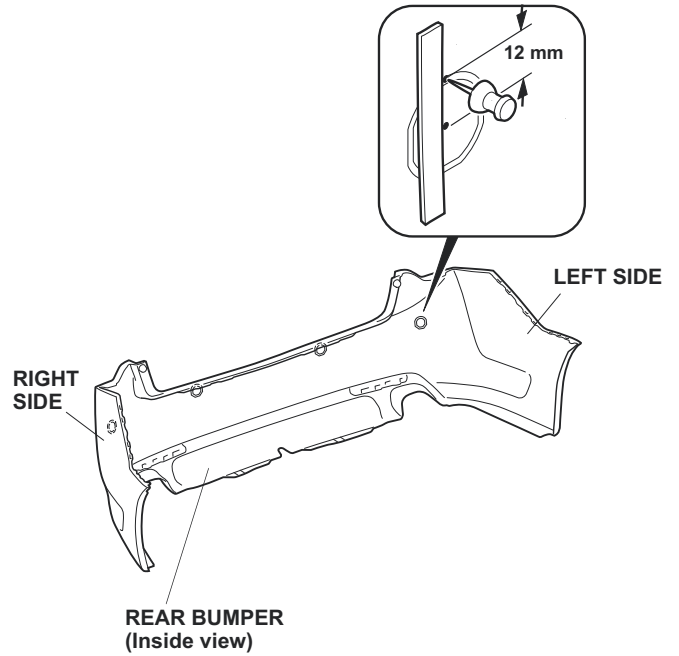

- On the right side of the bumper, use a straight edge to measure 12 mm **downward** from the center mark, and pierce the bumper.

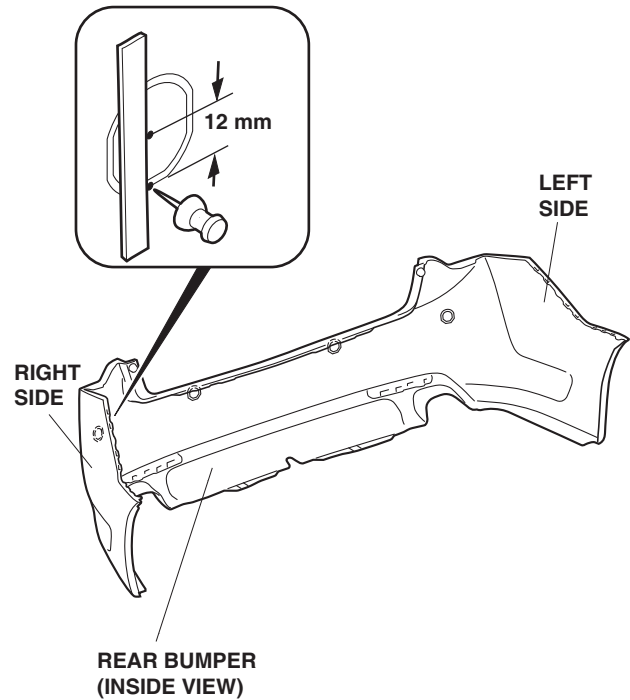

- At the two **center marks** on the bumper, use a straight edge to measure 13 mm **upward**, and pierce the bumper.

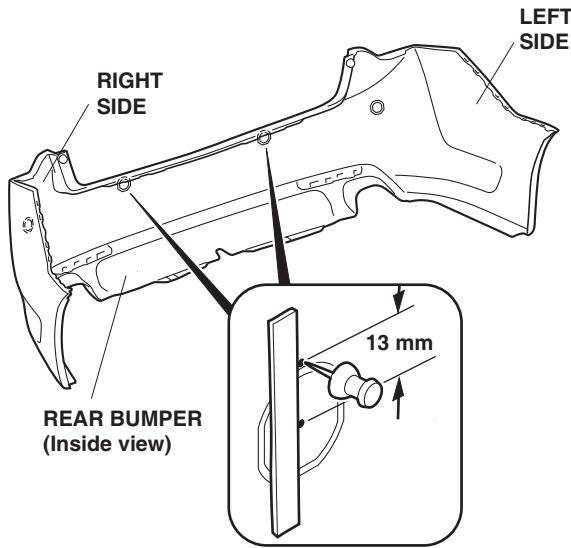

- On the **right side** of the bumper, drill the **lower hole** using a 3 mm bit, and drill the **upper hole** using a 24 mm hole saw.

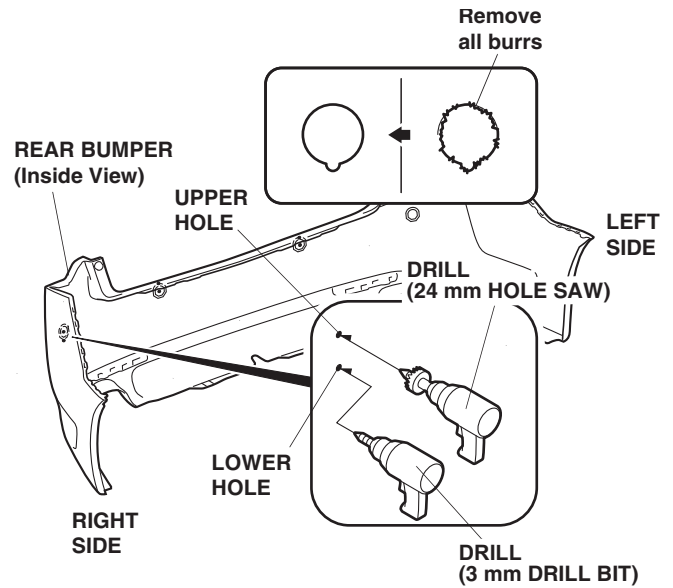

38. While wearing eye protection, drill the rear bumper:  
NOTE: All holes are drilled from the inside of the bumper.

- On the **left side** of the bumper, drill the **upper hole** using a 3 mm bit, and drill the **lower hole** using a 24 mm hole saw.

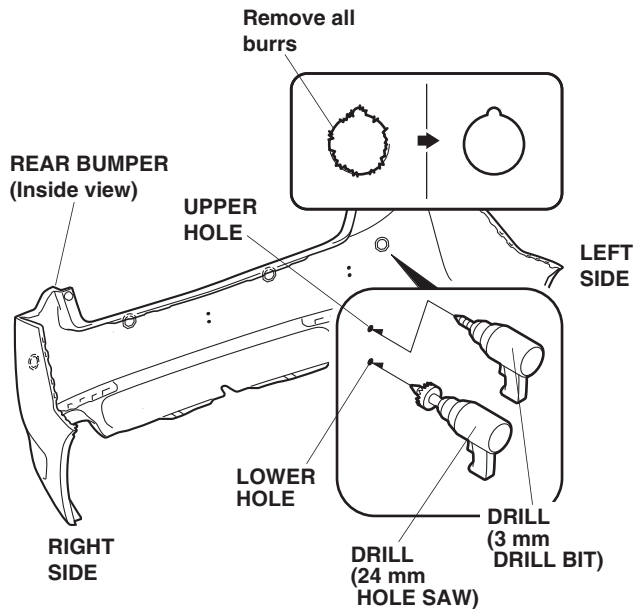

- For the center holes in the bumper, drill the **upper holes** using a 3 mm drill bit, and drill the **lower holes** using a 26 mm hole saw.

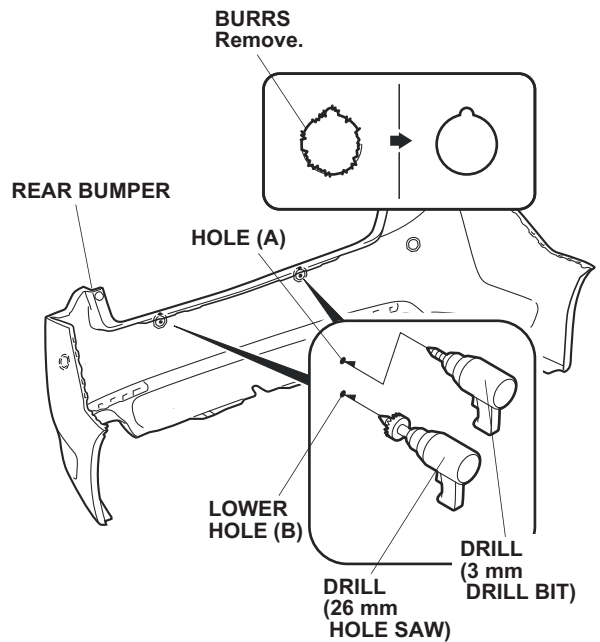

- Remove all burrs from each drilled hole.

39. Install the two corner sensors in the rear bumper using the two sensor clips as shown.

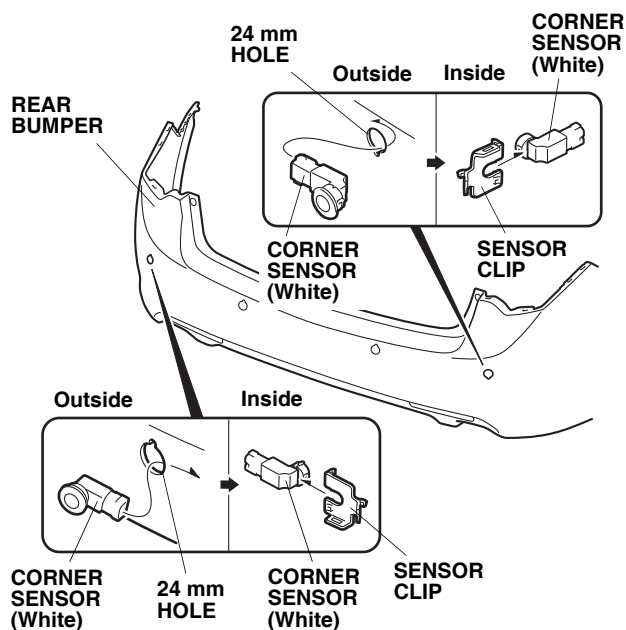

40. Install the two center sensors in the rear bumper using the two sensor clips as shown.

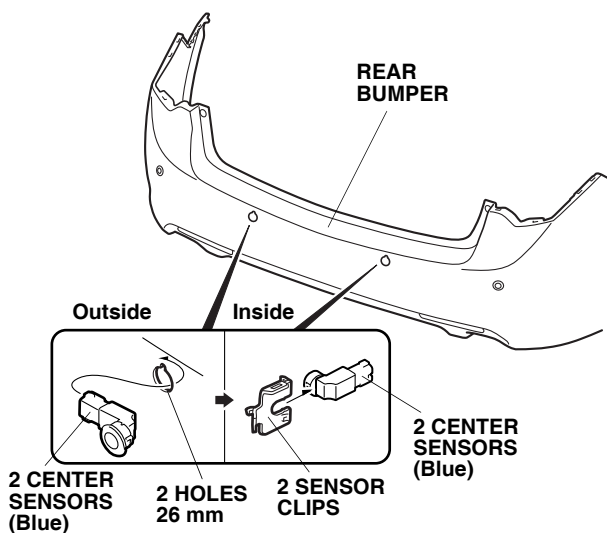

41. Plug in the four subharness 2-pin connectors to the left center sensor, the right center sensor, and the two corner sensors.

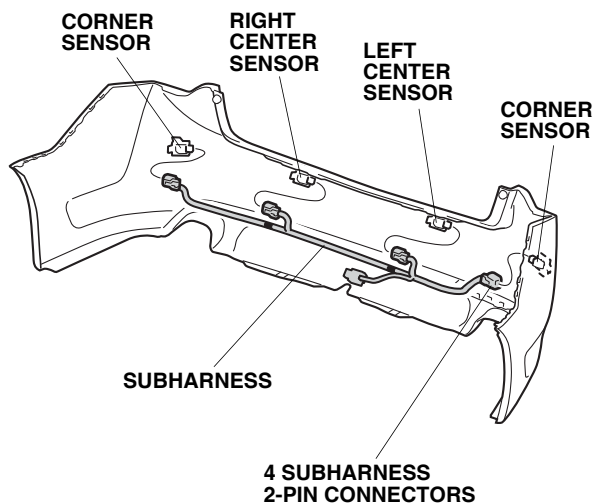

42. Align the green tape on the subharness with the holes in the left center sensor clip and the right center sensor clip, and secure the subharness to the left center sensor clip and the right center sensor clip using two wire ties as shown.

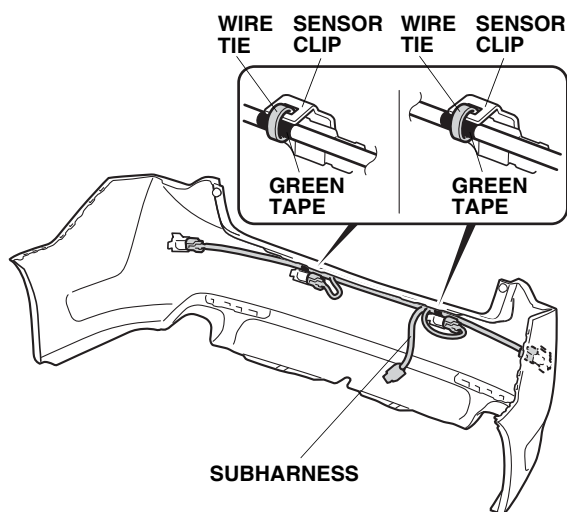

43. Using isopropyl alcohol on a shop towel, clean the area where the harness tape will attach.
44. Attach the subharness to the rear bumper with the harness tape.

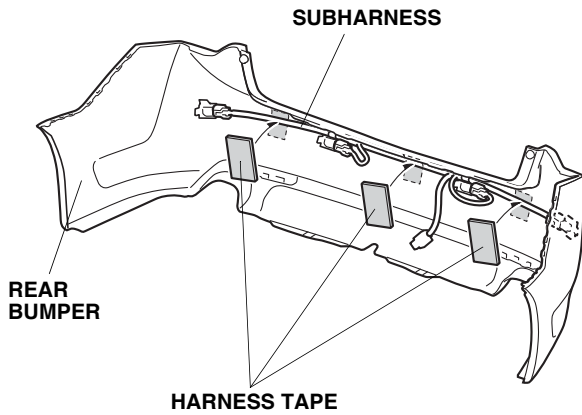

45. With the help of an assistant, bring the rear bumper close to the vehicle. Plug the subharness 8-pin connector into the sensor harness 8-pin connector, and install the rear bumper in the original position.

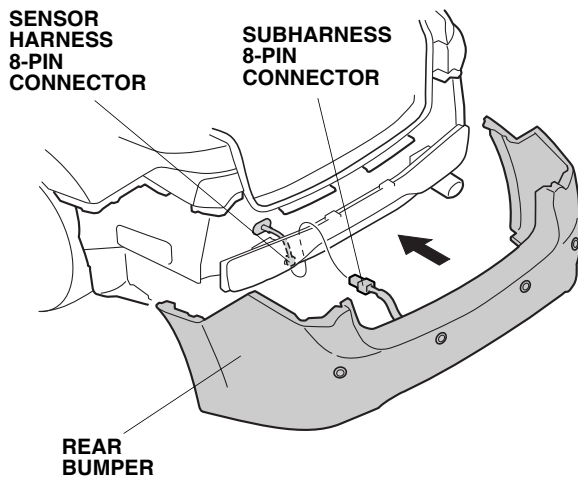

If the vehicle is equipped with an AERO bumper continue with step 46. If not go to step 55.

### Illustration of the Preset Marks on the Rear Aero Bumper

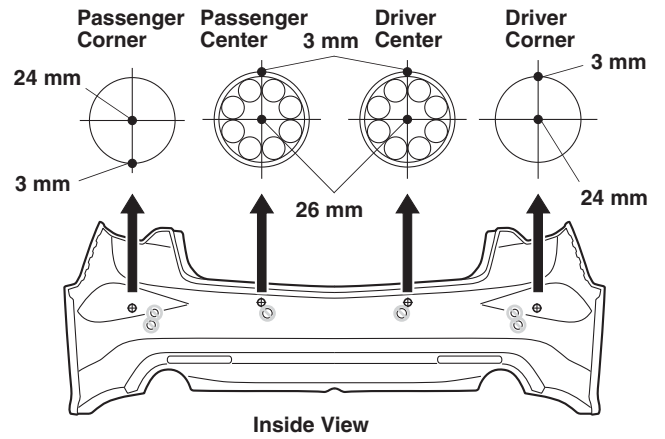

46. Mark the rear aero bumper:

- On the inside of the bumper, locate the four back-up sensor preset marks. There are several marks on the inside of the bumper, make sure the marks look like the marks in the illustration on page 13.
- On the **right side** of the bumper, pierce the **center** and the **bottom** scribe mark.

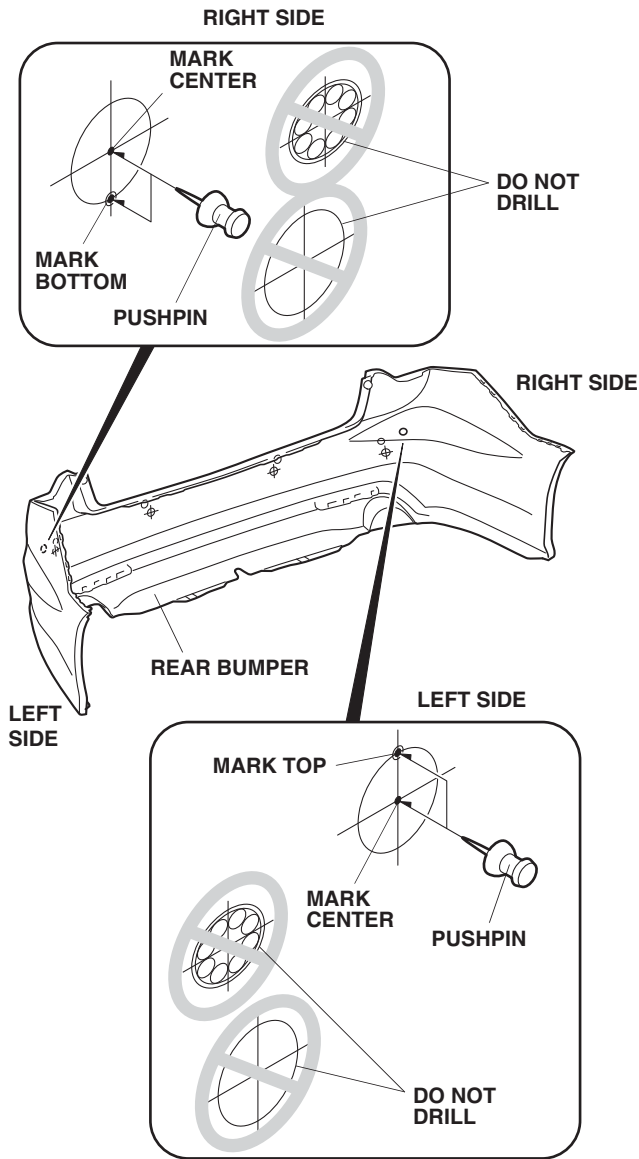

- On the **left side** of the bumper, pierce the **center** and the **top** of the scribe mark.

- At the two **center marks** on the bumper, pierce the center and the **top** of the scribe marks.

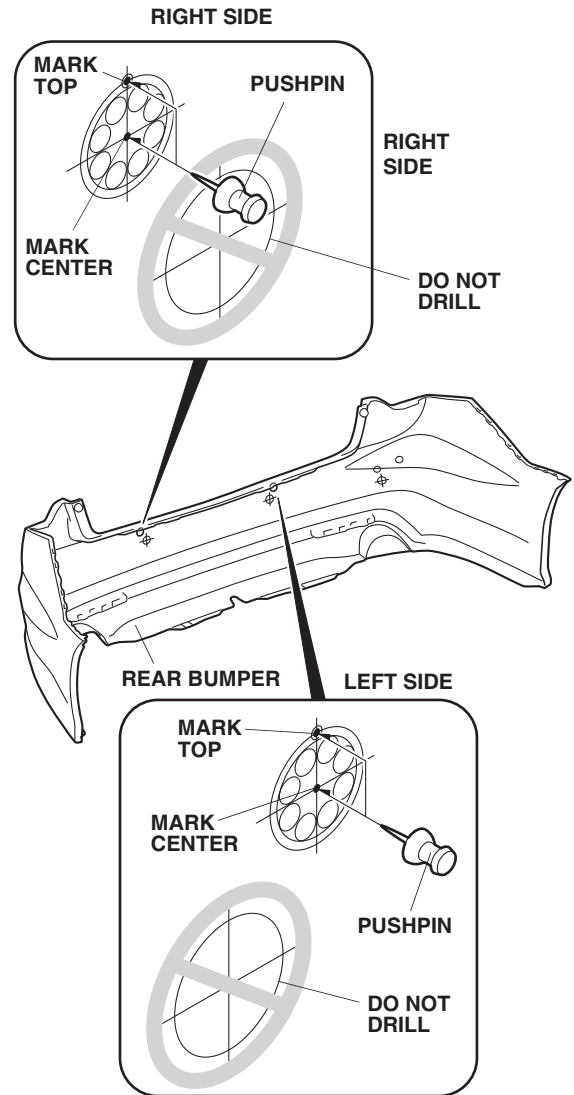

47. While wearing eye protection, drill the rear bumper. All holes are drilled from the inside of the bumper.
- On the **left side** of the bumper, drill the **upper hole** using a **3 mm** drill bit, and drill the **lower hole** using a **24 mm** hole saw.

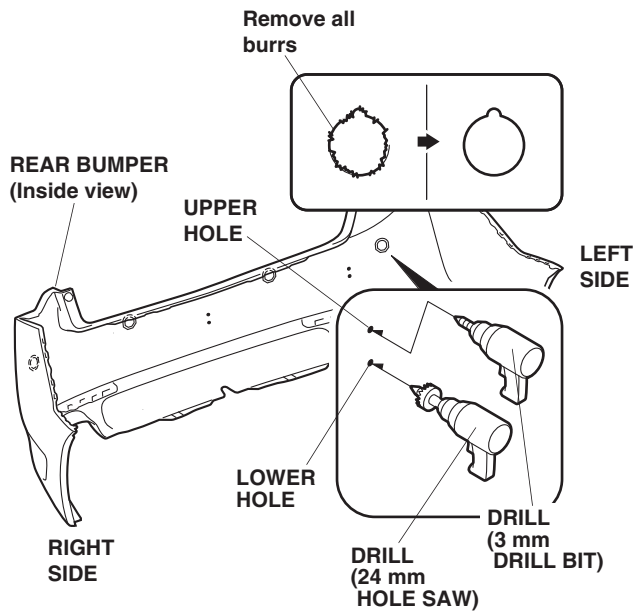

- On the **right side** of the bumper, drill the **lower hole** using a 3 mm bit, and drill the **upper hole** using a **24 mm** hole saw.

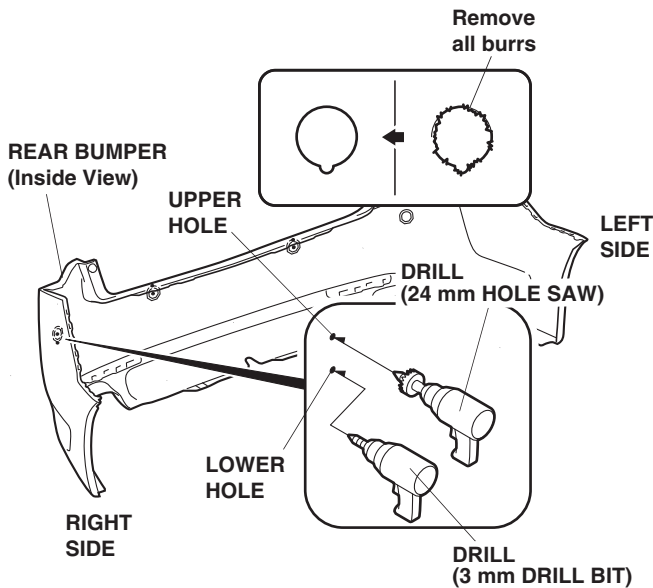

- For the center holes in the bumper, drill the **upper holes** using a **3 mm** drill bit, and drill the **lower hole** using a **26 mm** hole saw.

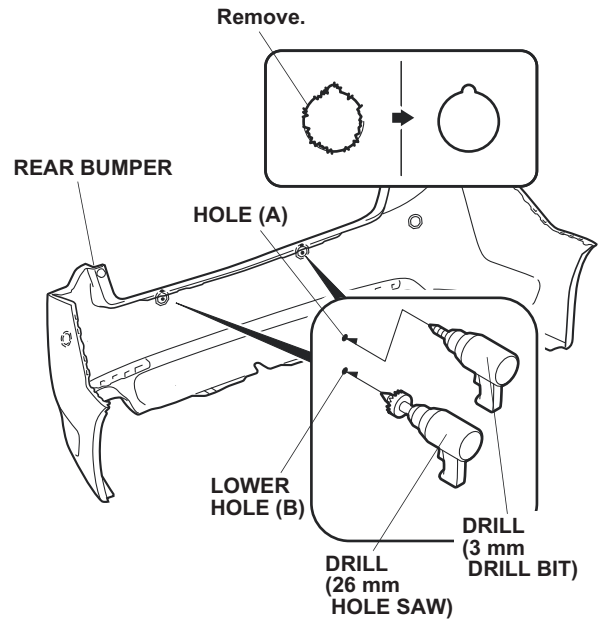

48. Install the two corner sensors in the rear bumper using the two sensor clips as shown.

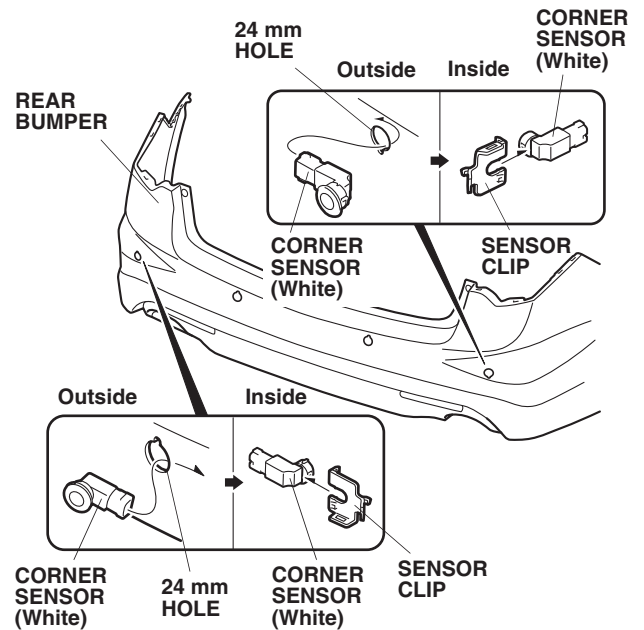

49. Install the two center sensors in the rear bumper using the two sensor clips as shown.

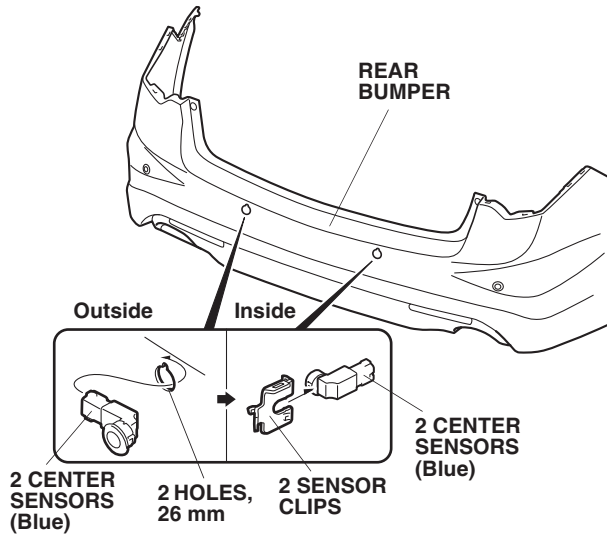

51. Align the green tape on the subharness with the holes in the left center sensor clip and the right center sensor clip, and secure the subharness to the left center sensor clip and right center sensor clip using two wire ties as shown.

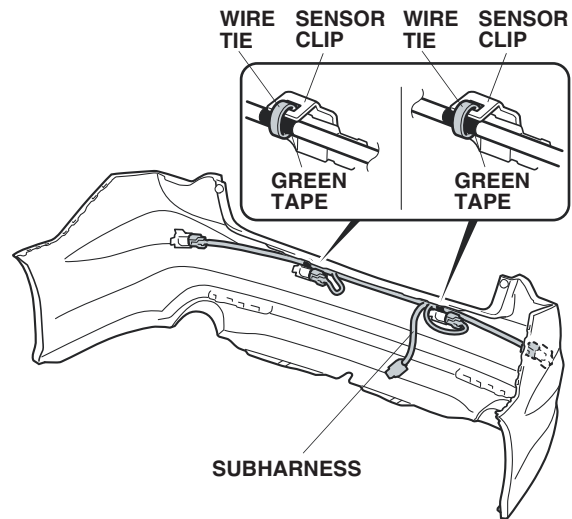

50. Plug in the four subharness 2-pin connectors to the left center sensor, the right center sensor, and the two corner sensors.

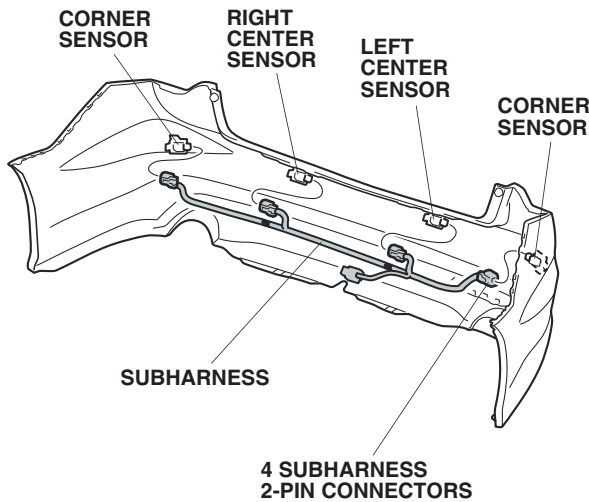

52. Using isopropyl alcohol on a shop towel, clean the area where the harness tape will attach.  
53. Attach the subharness to the rear bumper with the harness tape.

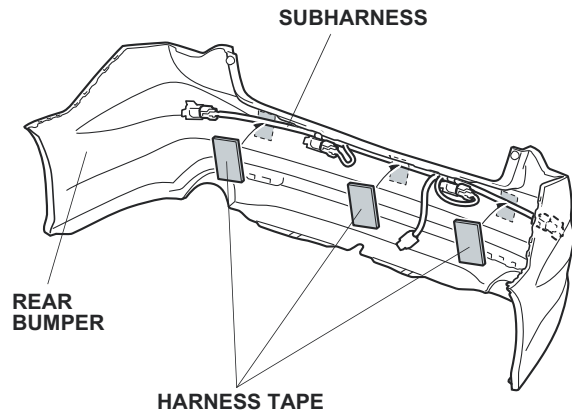



54. With the help of an assistant, bring the rear bumper close to the vehicle. Plug the subharness 8-pin connector into the sensor harness 8-pin connector, and install the rear bumper in the original position.

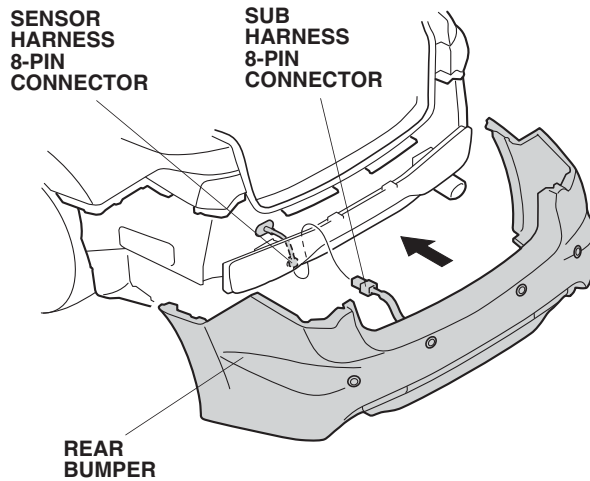

55. Check that all wire harnesses are routed properly and all connectors are plugged in.
56. Reinstall all removed parts.
57. Connect the negative cable to the battery and check operation of all lights and other electrical accessories.
58. Enter the anti-theft codes for the audio system and the navigation system (if equipped).
59. Reset the clock on vehicles without navigation.
60. Check that the back-up sensors work properly as described in the Accessory User's Information Manual supplied with the back-up sensors attachment kit.

### Buzzer Volume Control

The original volume setting is turned to the maximum volume. The volume level can be adjusted by turning the volume control knob on the control unit using a small flat-tip screwdriver.

