



INSTALLATION INSTRUCTIONS

Accessory
BACKUP SENSORS

Application
**2012 TSX
SPORT WAGON**

Publications No.
BII 46267
Issue Date
AUG 2011

PARTS LIST

**Backup Sensor Attachment Kit
P/N 08V67-TL7-200A**

Control unit

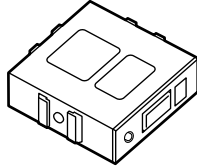

Buzzer

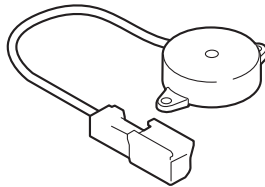

Control unit bracket

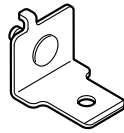

Backup sensor harness

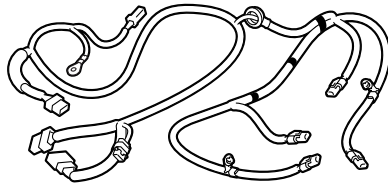

11 Wire ties

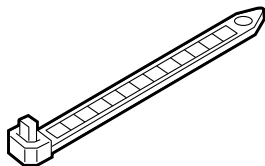

4 Aluminum tapes



Fuse seal



Urethane tape

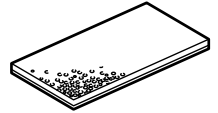

Ground bolt

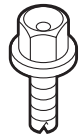

3 Wire ties with clips

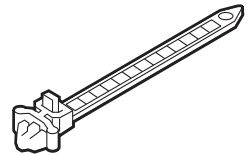

2 Left sensor clips (White)

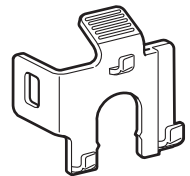

2 Right sensor clips (Black)

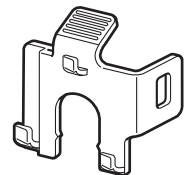

Flange nut



Accessory User's Information Manual

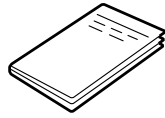

**Backup Sensor Kit
P/N 08V67-TL7-200K**

Left corner sensor

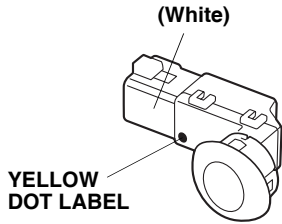

Right corner sensor

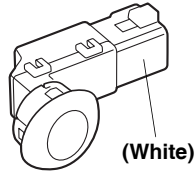

Left center sensor

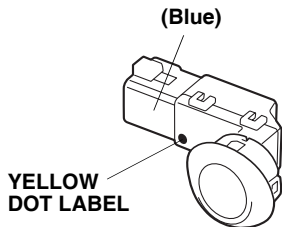

Right center sensor

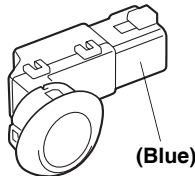

TOOLS AND SUPPLIES REQUIRED

- Phillips screwdriver
- Flat-tip screwdriver
- Shop towel
- Ratchet
- 8 mm and 10 mm Sockets
- Pushpin
- Drill
- 3 mm Drill bit
- 24 mm and 26 mm Hole saws
- Eye protection (face shield, safety goggles, etc.)
- 10 mm Open end wrench
- File
- Diagonal cutters
- Isopropyl alcohol
- Trim Tool Set (T/N SOJATP2014)
- Blanket
- Utility knife
- Scissors
- Torque wrench
- Small flat-tip screwdriver

Illustration of the Backup Sensors Installed on the Vehicle

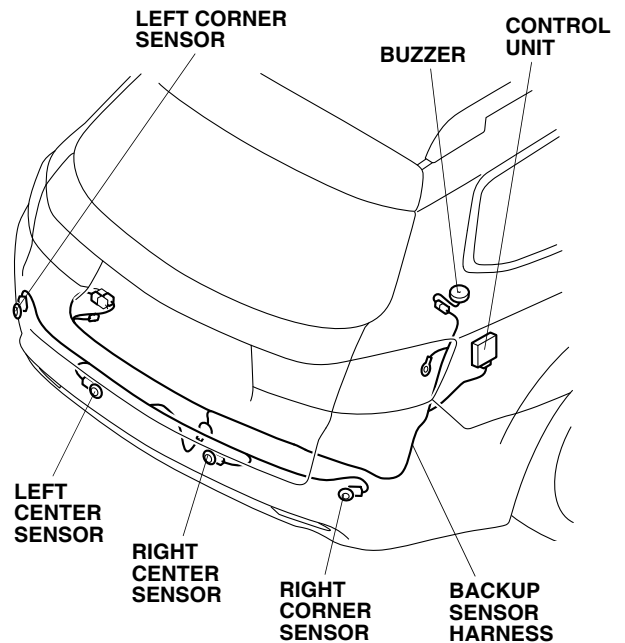

INSTALLATION

Client Information: The information in this installation instruction is intended for use only by skilled technicians who have the proper tools, equipment, and training to correctly and safely add equipment to your vehicle. These procedures should not be attempted by “do-it-yourselfers.”

1. Make sure you have the anti-theft code for the radio and navigation system if equipped, then write down the radio station presets.
2. Open the tailgate. Disconnect the negative cable from the battery.
3. Release the tonneau cover from the vehicle panel.

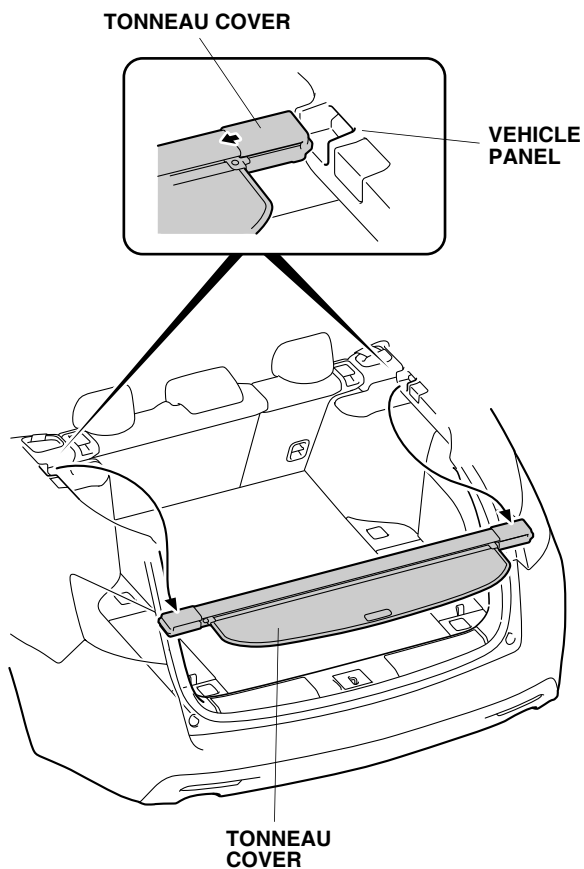

4. Remove the tonneau cover from the vehicle.

5. Pull the left rear seatback lock opener to tilt the left rear seatback forward.

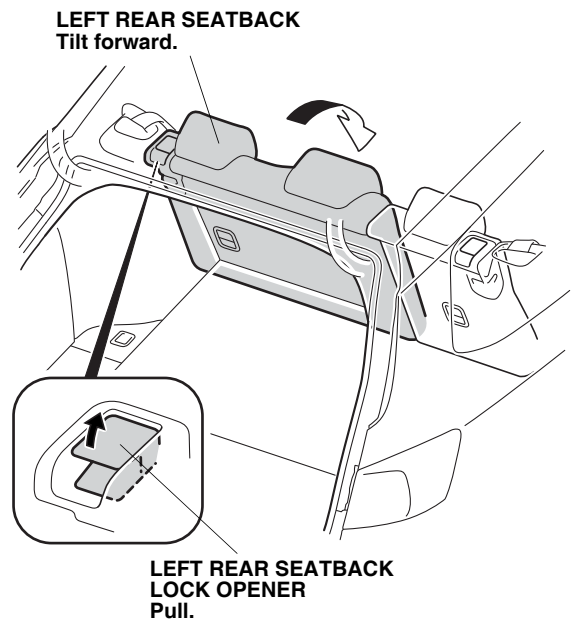

6. Remove the cargo floor lid (two clips).

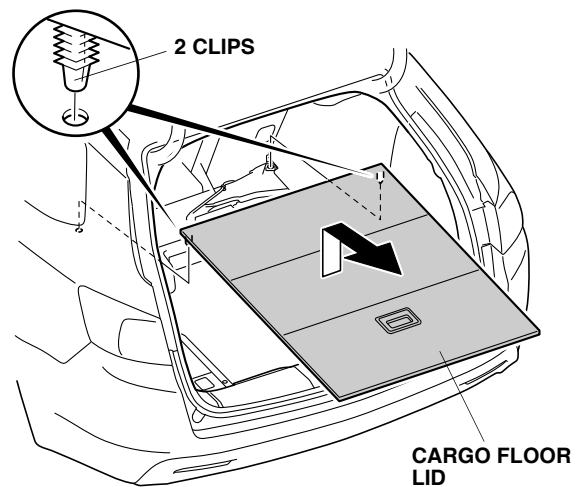

7. Remove the cargo under tray.

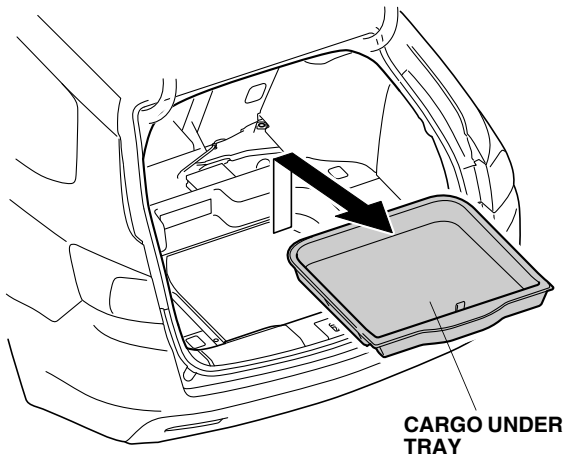

8. Remove the tool box spacer.

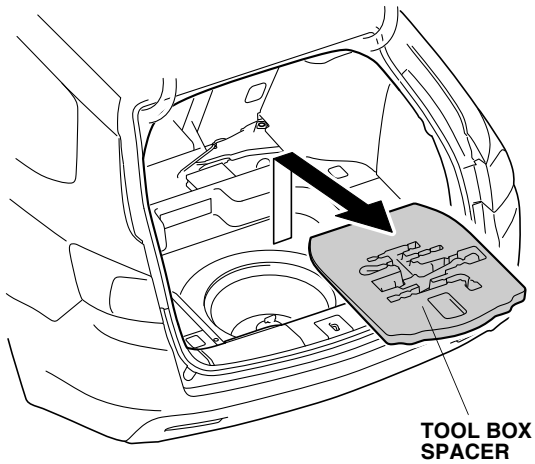

9. Remove the bolt from the rear seat cushion.
NOTE: Torque the bolt to 9.8 N·m (1.0 kgf·m, 7.2 lbf·ft) when reinstalling the bolt.

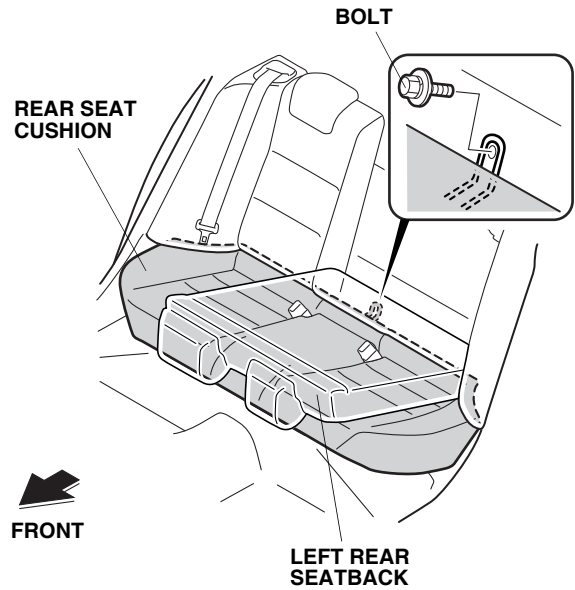

10. Return the left rear seatback to the original position.
11. Pull two seat hook knobs, and release two hooks.

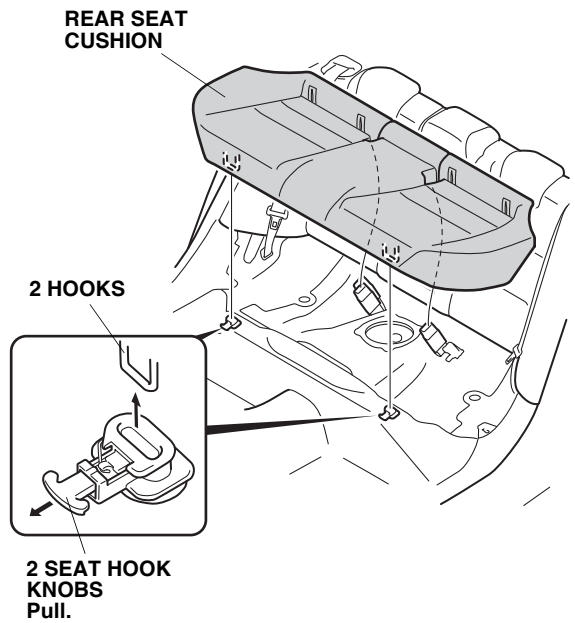

12. Remove the rear seat cushion.

13. Pull the right rear seatback lock opener to tilt the right rear seatback forward.

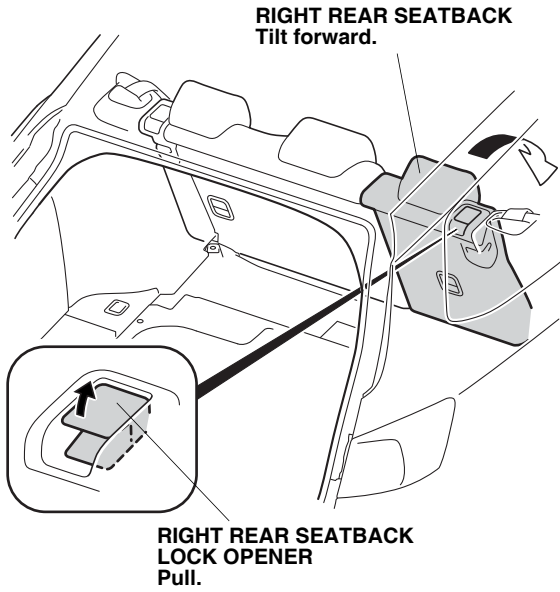

14. Remove the right seat side bolster (one bolt and two hooks).

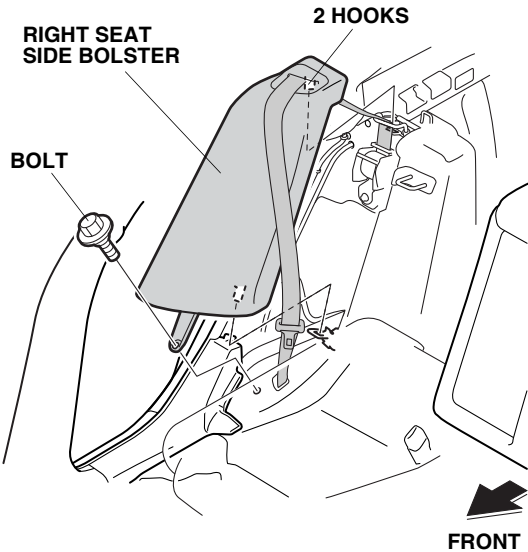

15. Pull away the weatherstrip, and remove the rear trim panel (six clips, two clips, and two retaining tabs).

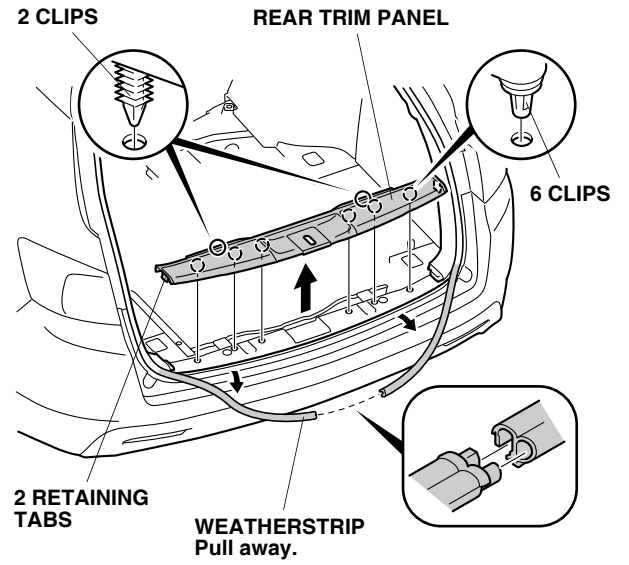

16. Remove the rear under floor cover (four clips).

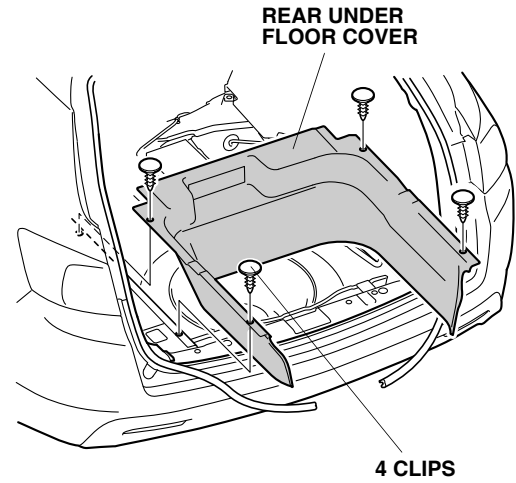

17. Remove the lid from the right rear side trim panel (one clip and one hook).

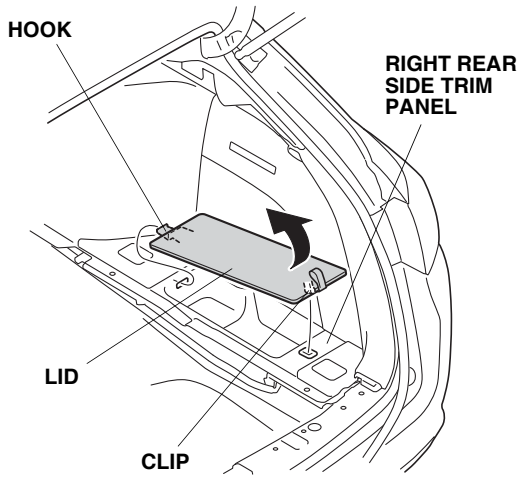

18. Remove three tie down hooks from the right rear side trim panel (open the cover, and remove the screw).

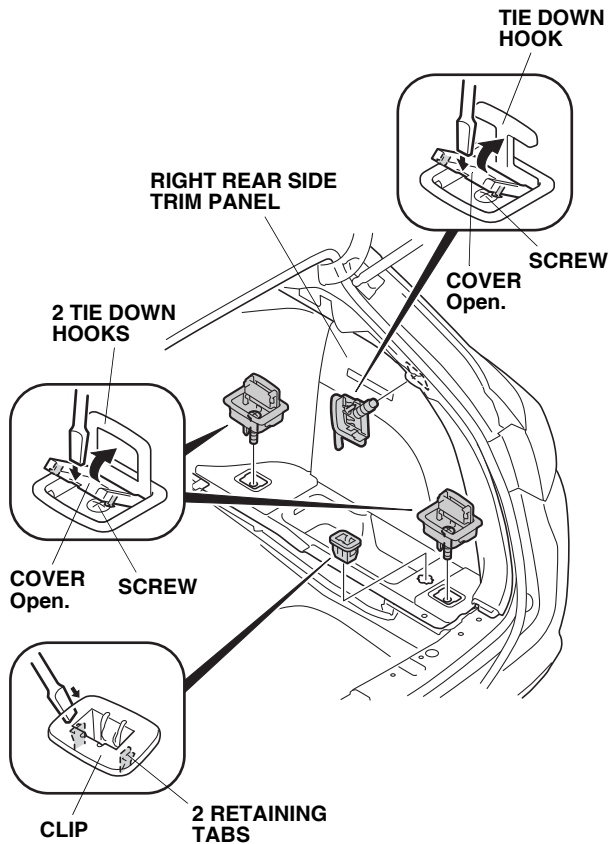

19. Remove the clip from the right rear side trim panel (two retaining tabs).

20. Remove the lid from the right rear side trim panel (four retaining tabs).

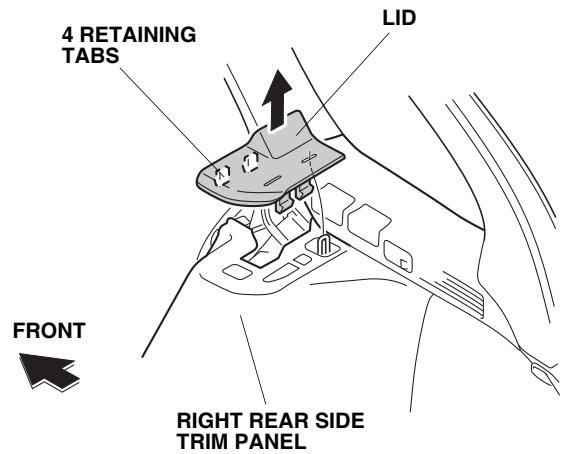

21. Pull away the weatherstrip, and remove the right rear side trim panel (seven clips, one hook, and unplug the vehicle connector).

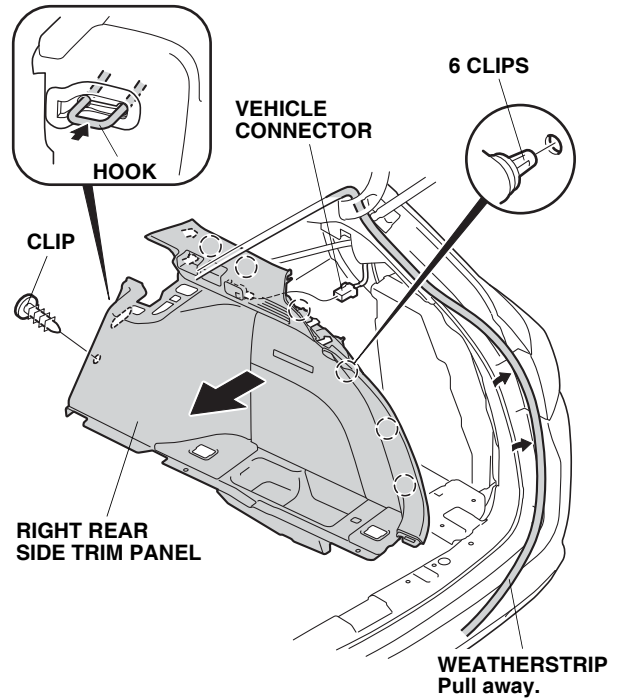

If the vehicle is equipped with a subwoofer, continue with step 22; otherwise, go to step 23.

With Subwoofer

22. Remove the subwoofer (four bolts and unplug the vehicle connector).

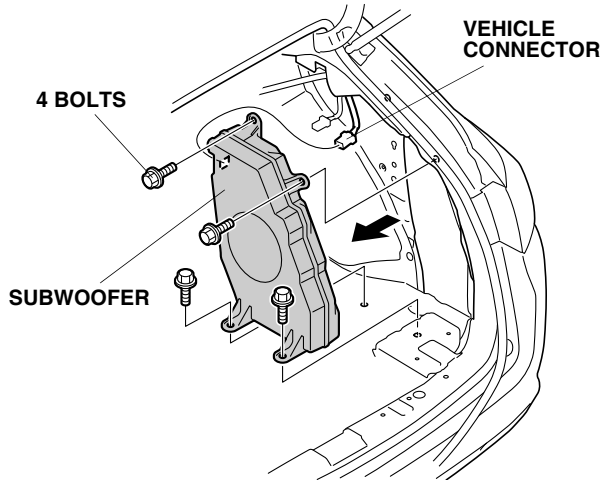

23. Remove four caps and four bolts from the rear bumper.

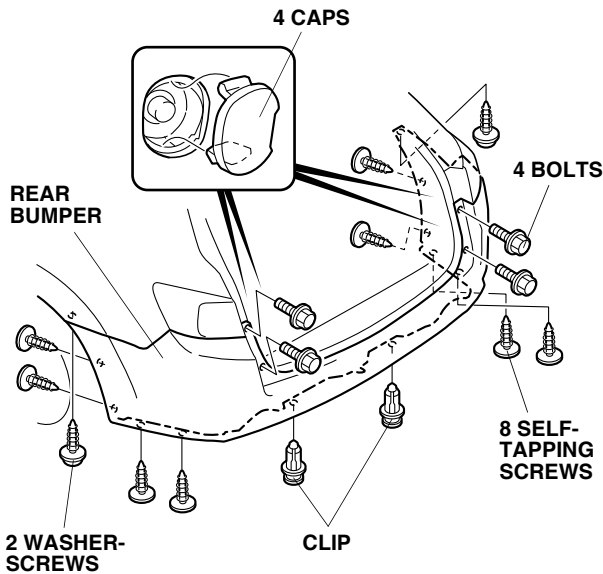

24. Remove two clips, two washer-screws, and eight self-tapping screws from the rear bumper.

25. Remove the rear bumper (two retaining tabs).
NOTE: Have an assistant help you when removing the rear bumper. Place the rear bumper on a blanket after removal to prevent damage to the paint.

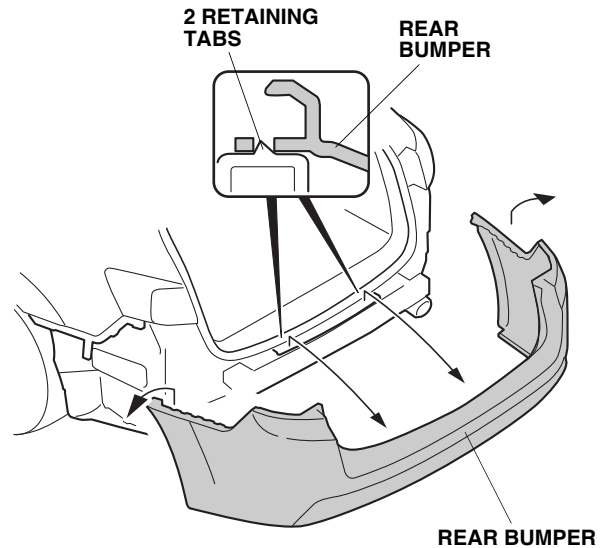

26. Remove the rear bumper absorber.

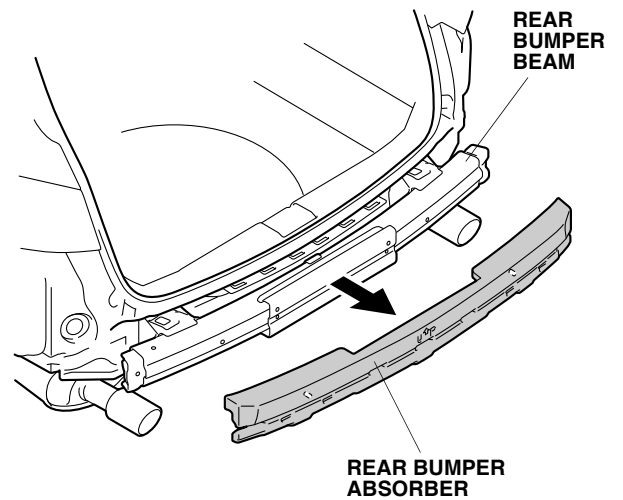

Installing the Control Unit

27. Insert the control unit bracket into the control unit.

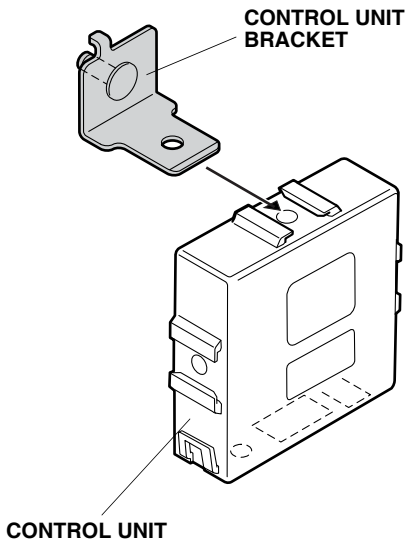

28. Align the control unit bracket to the hole in the vehicle panel as shown. Install the control unit to the vehicle panel with one flange nut.

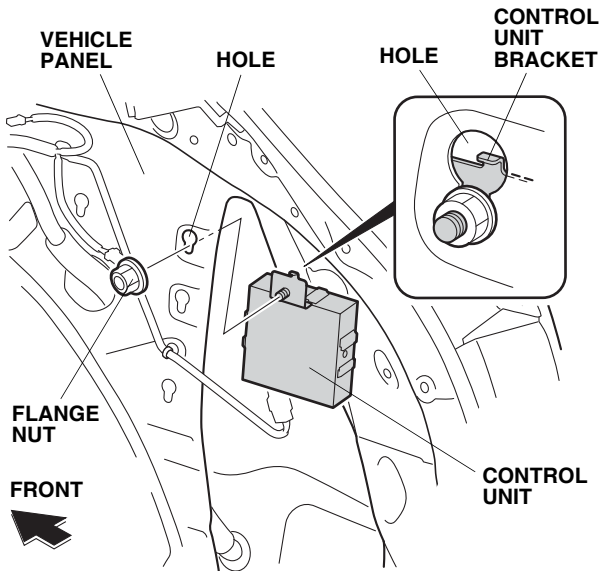

Routing the Backup Sensor Harness

29. Using isopropyl alcohol on a shop towel, thoroughly clean the area where the fuse label will attach. Attach the 2A fuse label to the fuse case on the backup sensor harness.

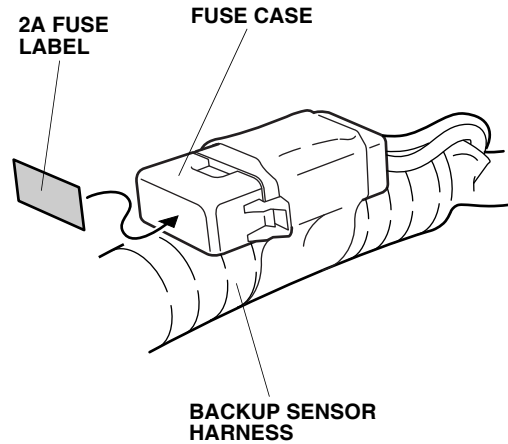

30. Route the backup sensor harness along the vehicle harness as shown.

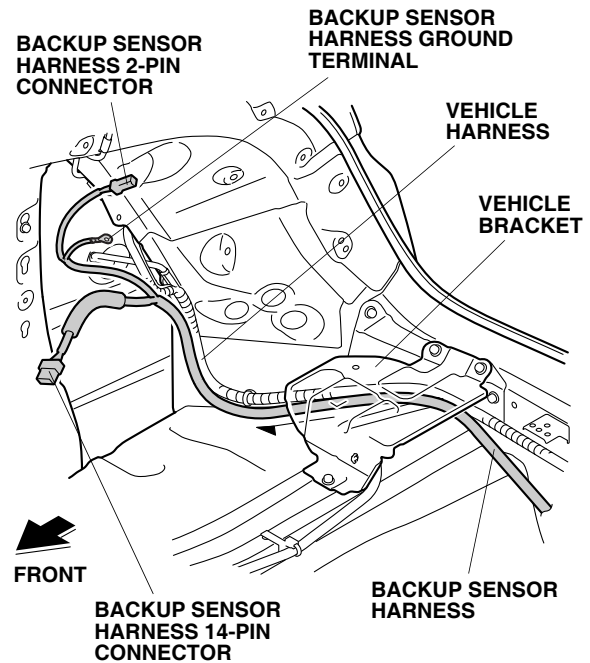

31. Plug the backup sensor harness 14-pin connector to the control unit.

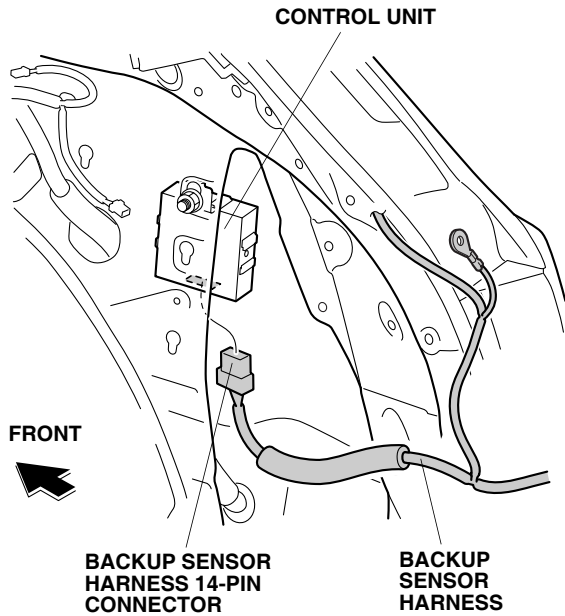

32. Secure the backup sensor harness ground terminal to the vehicle panel with one ground bolt.

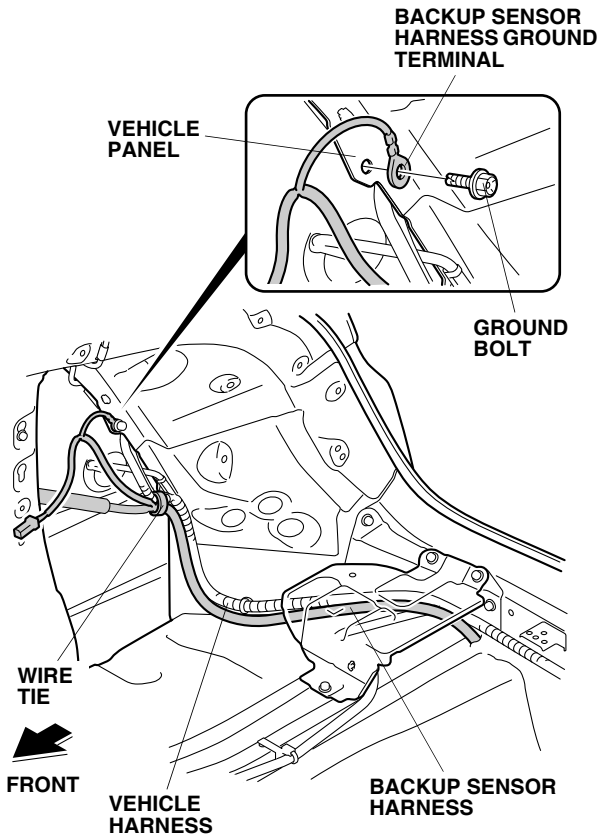

33. Secure the backup sensor harness to the vehicle harness with one wire tie.

34. Remove and discard the vehicle grommet from the vehicle panel.

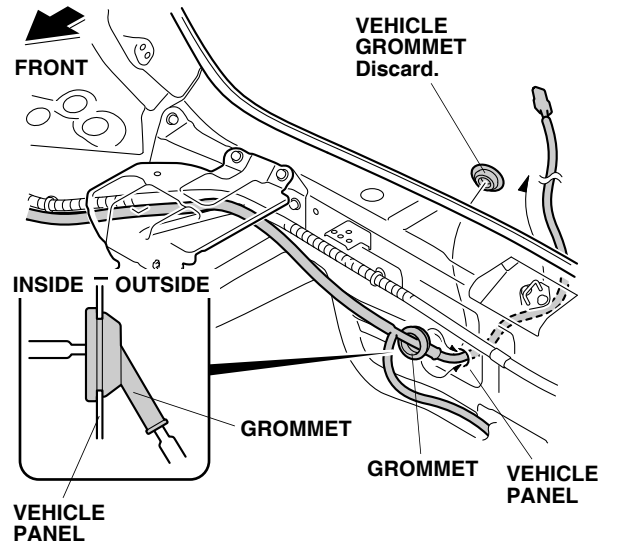

35. Route the backup sensor harness through the vehicle panel, and install the grommet on the backup sensor harness to the vehicle panel as shown. NOTE: Do not pull on the backup sensor harness when installing the grommet.

36. Secure the backup sensor harness to the vehicle harness with five wire ties.

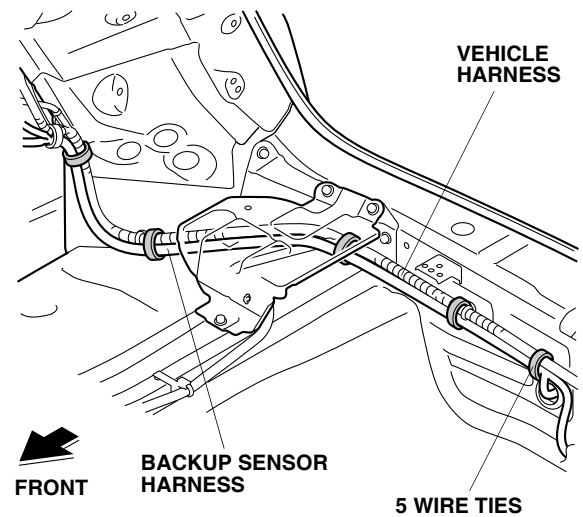

37. Route the backup sensor harness along the vehicle harness.

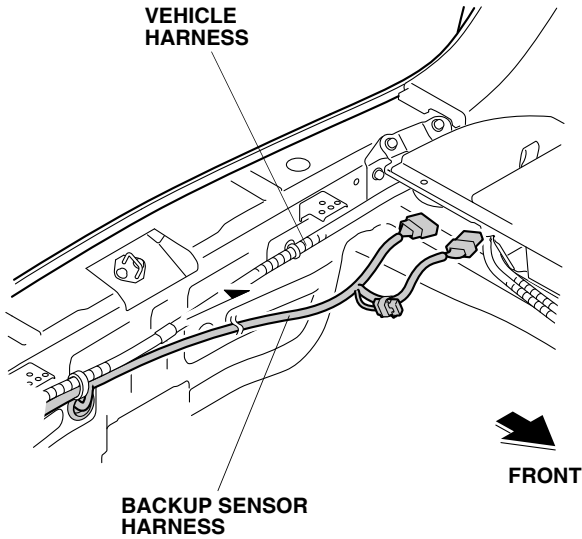

38. Unplug the vehicle 20-pin connector, and plug it to the backup sensor harness 20-pin connector.

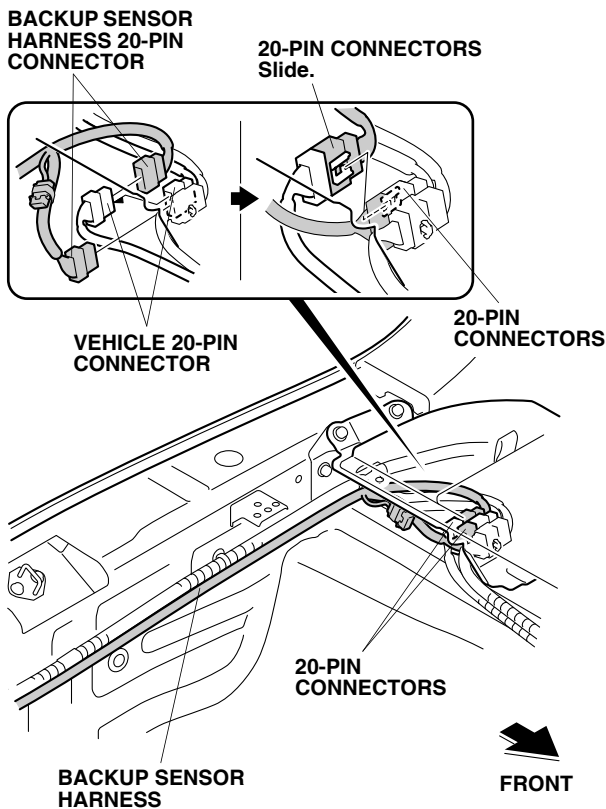

39. Plug the backup sensor harness 20-pin connector to the vehicle 20-pin connector.
40. Secure the 20-pin connectors together.

41. Secure the backup sensor harness to the vehicle harness with three wire ties.

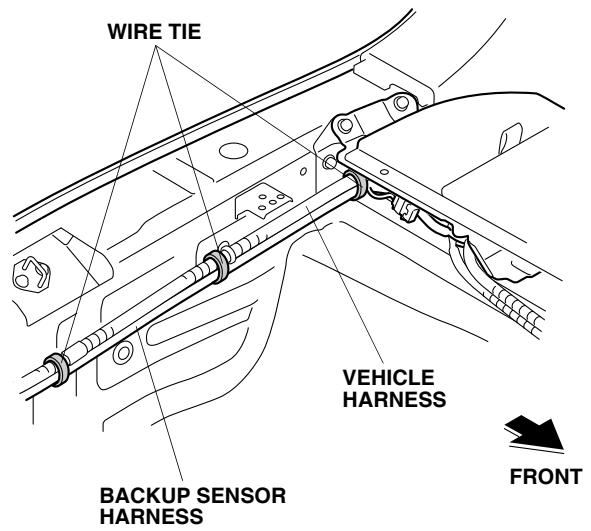

42. Using isopropyl alcohol on a shop towel, thoroughly clean the area where the buzzer will attach.

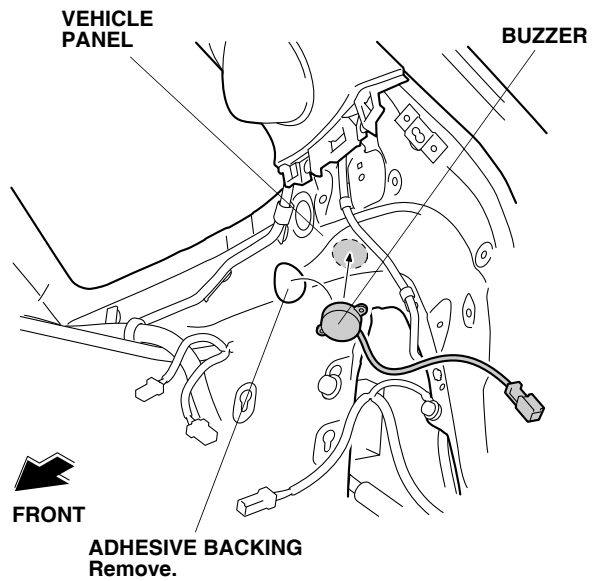

43. Remove the adhesive backing from the buzzer and attach the buzzer to the vehicle panel.

If the vehicle is equipped with a vehicle harness, continue with step 49; if not, go to step 44.

Without Vehicle Harness

44. Plug the buzzer harness 2-pin connector to the backup sensor harness 2-pin connector.

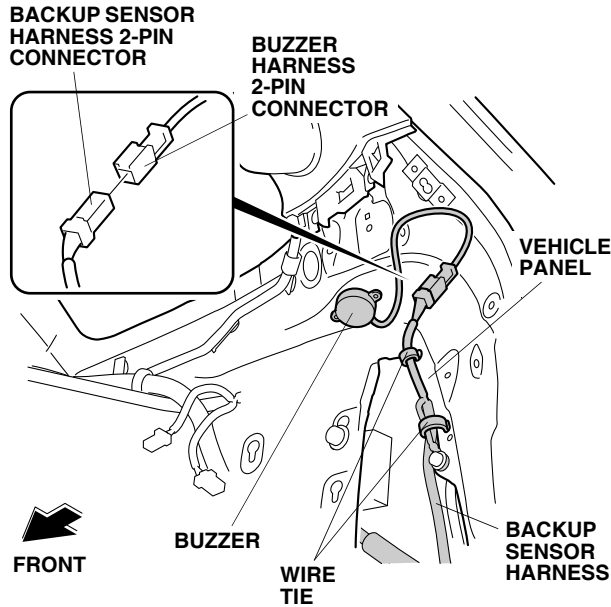

45. Secure the backup sensor harness to the vehicle panel with two wire ties.
46. Bundle the excess buzzer harness, and secure it and the 2-pin connectors with urethane tape as shown.

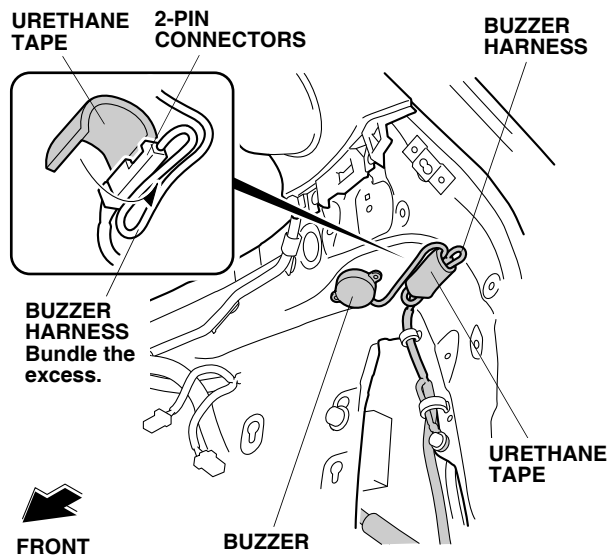

47. Using isopropyl alcohol on a shop towel, thoroughly clean the area where the aluminum tape will attach.

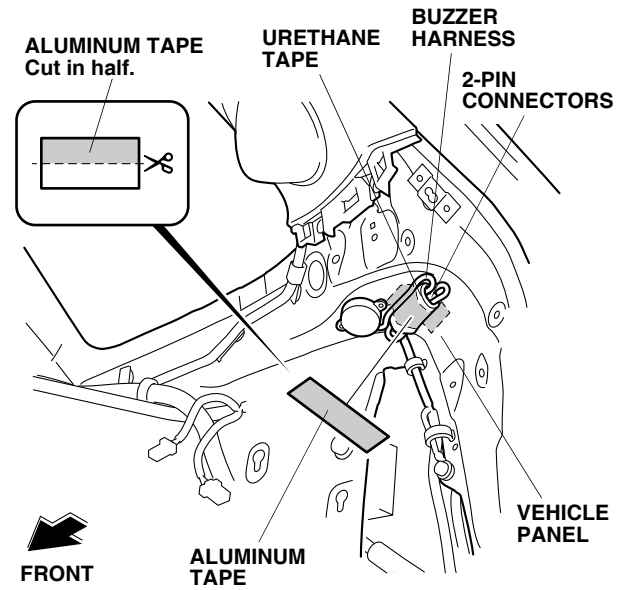

48. Using scissors, cut one aluminum tape in half. Secure the buzzer harness and 2-pin connectors to the vehicle panel with one piece of aluminum tape. Go to step 52.

With Vehicle Harness

49. Plug the buzzer harness 2-pin connector to the backup sensor harness 2-pin connector.

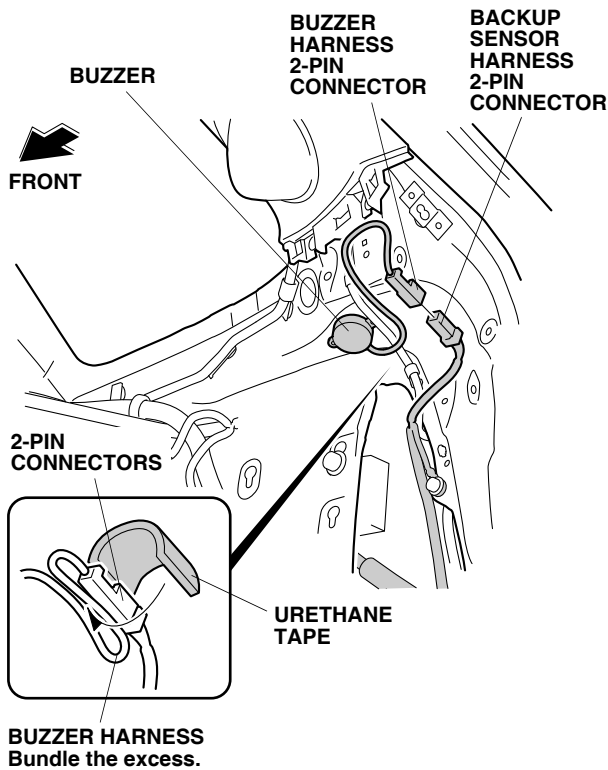

50. Bundle the excess buzzer harness, and secure it and the 2-pin connector with one urethane tape as shown.
51. Secure the buzzer harness, 2-pin connector, and backup sensor harness to the vehicle harness with two wire ties.

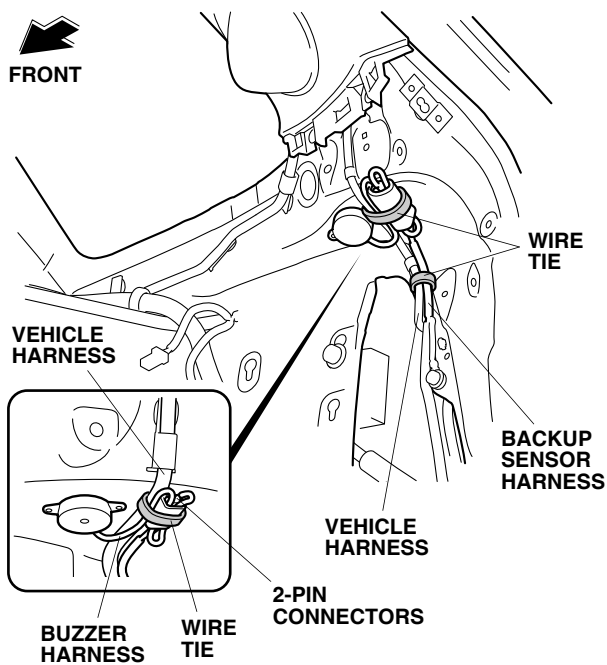

52. Route the backup sensor harness as shown.

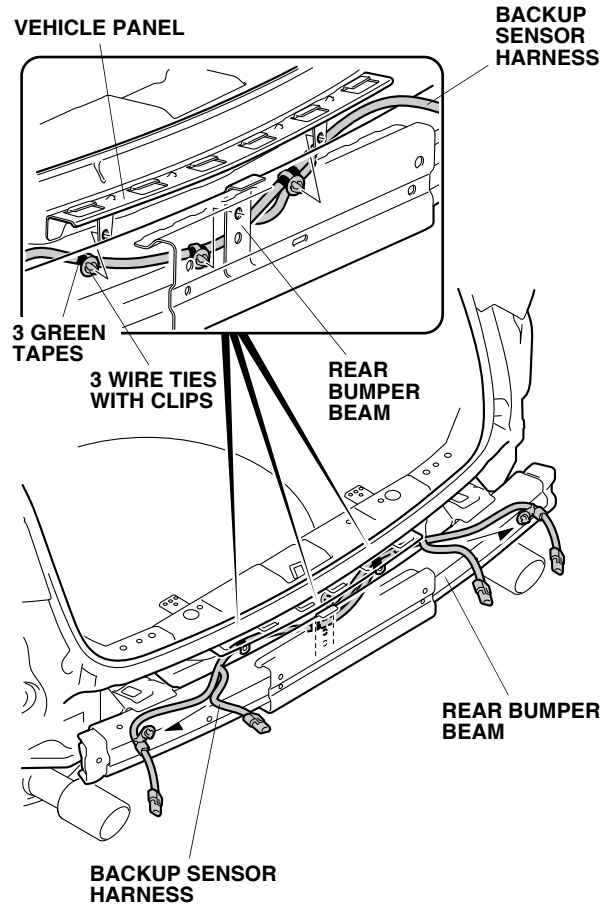

53. Secure three wire ties with clips to the backup sensor harness at the green tapes. Install the clips to the rear bumper beam and vehicle panel.

54. Secure two clips on the backup sensor harness to the rear bumper beam.

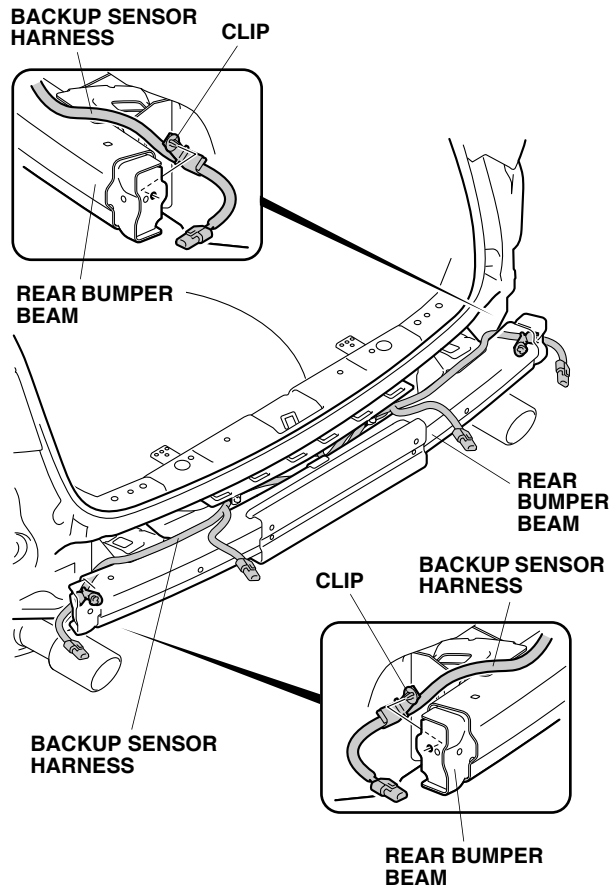

55. Using isopropyl alcohol on a shop towel, thoroughly clean the areas where the aluminum tape will attach.

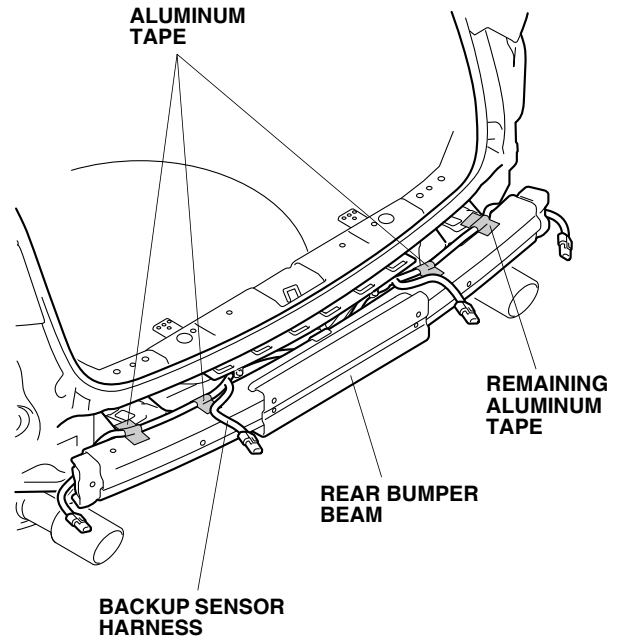

56. Secure the backup sensor harness to the rear bumper beam with three pieces of aluminum tape.
57. Secure the backup sensor harness to the rear bumper beam with the remaining piece of aluminum tape.

58. Using a utility knife, cut out the rear bumper absorber along the scribe lines as shown.

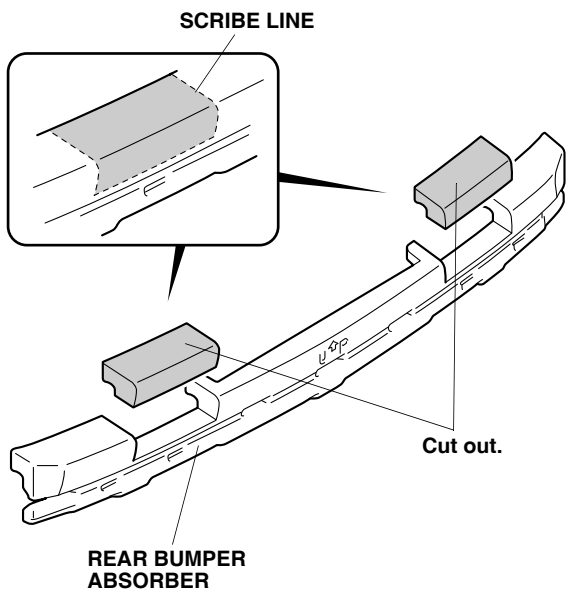

59. Reinstall the rear bumper absorber to the rear bumper beam.

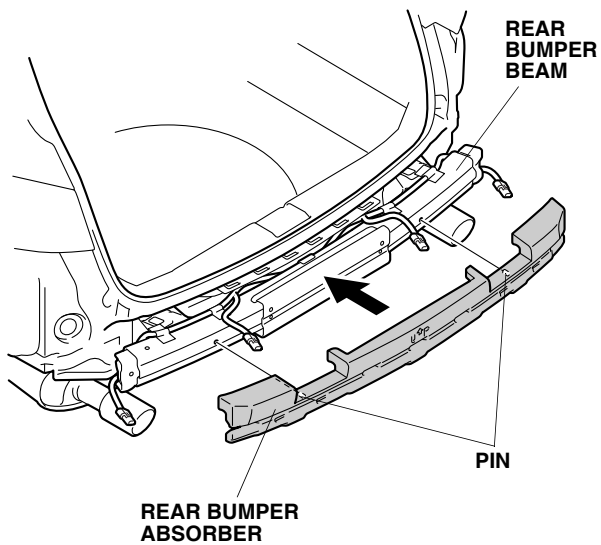

Installing the Backup Sensors

60. On the inside of the rear bumper, use a pushpin to pierce eight marks as shown.
NOTE: Make sure to pierce the scribe marks straight into the rear bumper.

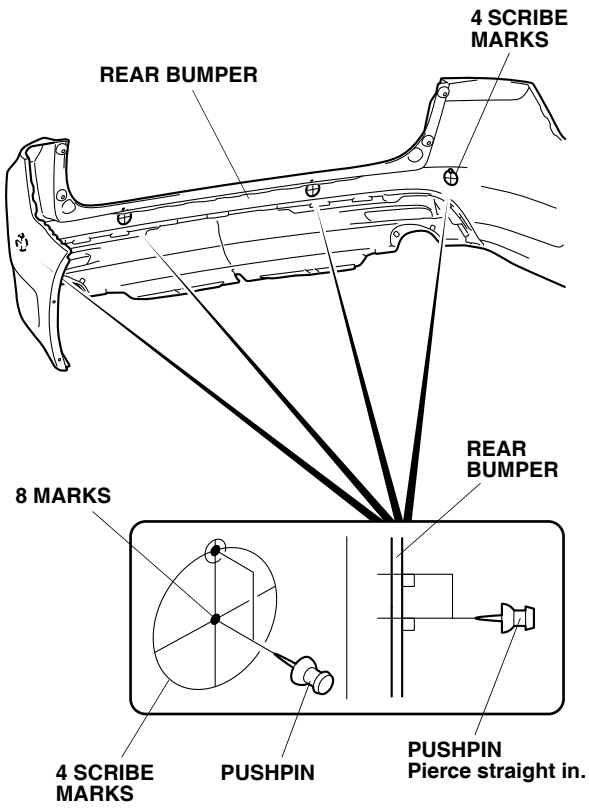

61. While wearing eye protection, drill eight holes with a 3 mm drill bit from the outside of the rear bumper.
NOTE: Make sure to drill at a right angle to the rear bumper.

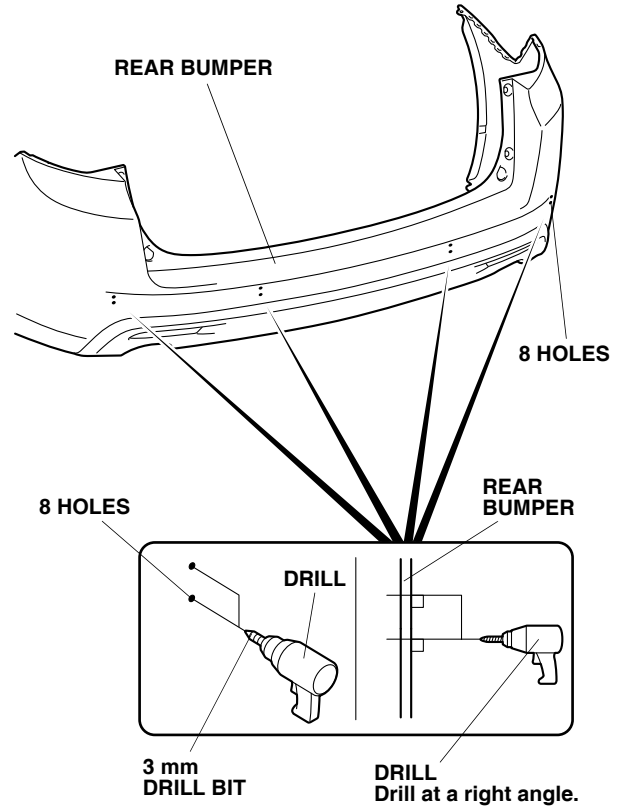

62. While wearing eye protection, drill two outer lower holes with a 24 mm hole saw from the outside of the rear bumper.
- NOTE: Make sure to drill at a right angle to the rear bumper. Remove any burrs.

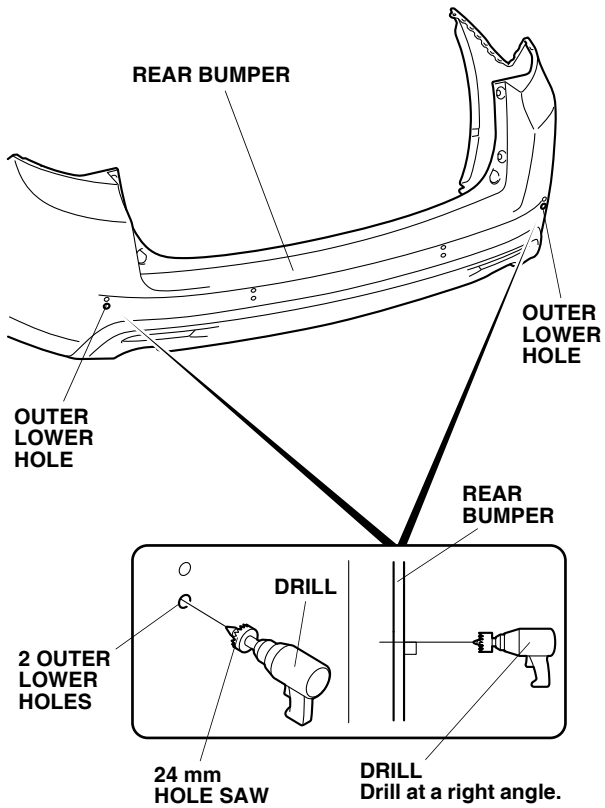

63. While wearing eye protection, drill two inner lower holes with a 26 mm hole saw from the outside of the rear bumper.
- NOTE: Make sure to drill at a right angle to the rear bumper. Remove any burrs.

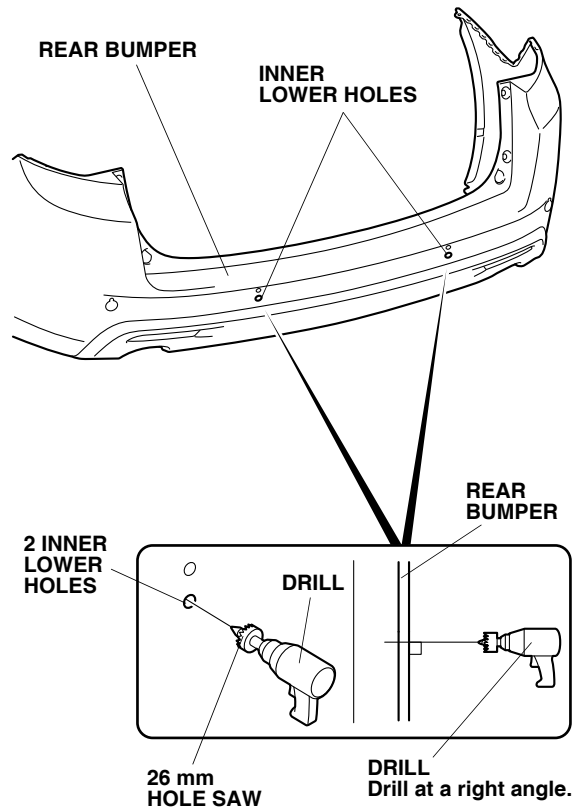

64. Insert the left corner sensor (White) and left center sensor (Blue) into the rear bumper.
 NOTE: The left corner sensor (White) and the left center sensor (Blue) have a yellow dot on the label.

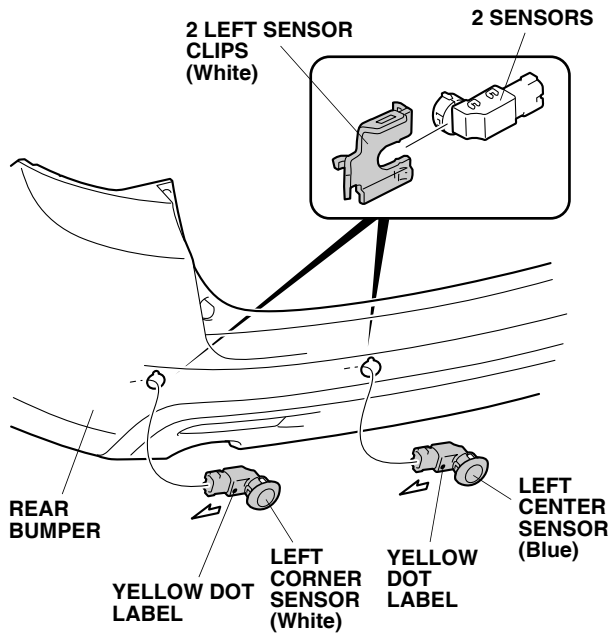

65. Secure the left corner sensor and left center sensor with left sensor clips (White) as shown.

66. Insert the right corner sensor (White) and right center sensor (Blue) into the rear bumper.

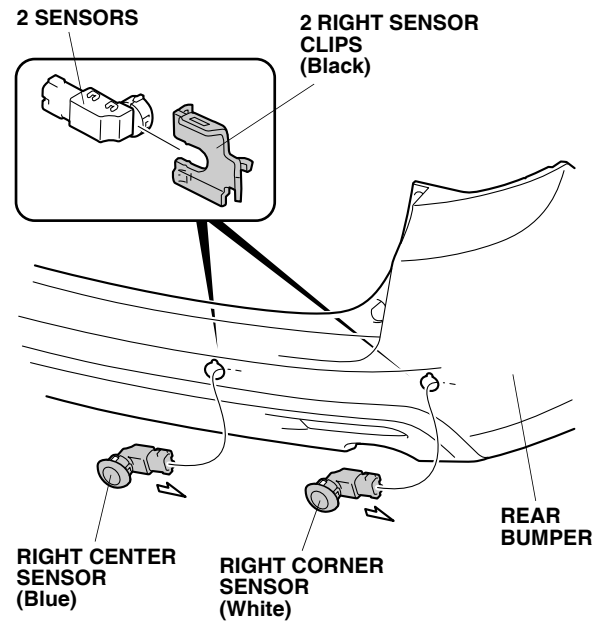

67. Secure the right corner sensor and right center sensor with right sensor clips (Black) as shown.

68. Lift the rear bumper to the vehicle, and plug four backup sensor harness 2-pin connectors to the four sensors in the rear bumper.

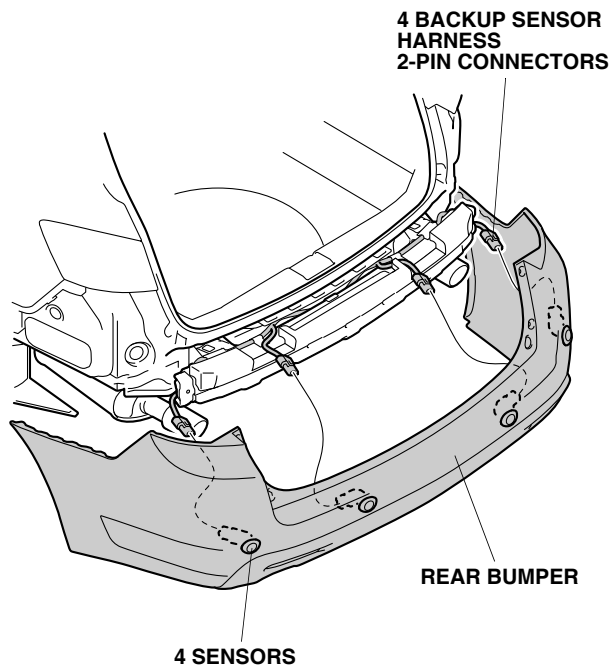

69. Have an assistant help you reinstall the rear bumper.
70. Check that all wire harnesses are routed properly and all connectors are plugged in.
71. Reinstall all removed parts.
72. Reconnect the negative cable to the battery.
73. Enter the customer's anti-theft code for the audio and navigation system if equipped, and reset the radio station presets.
74. Reset the clock.
75. Check that the backup sensors work properly as described in the Accessory User's Information Manual supplied with the backup sensor kit.

Buzzer Volume Control

The original volume setting is turned to maximum volume. The volume level can be adjusted by turning the volume control knob on the control unit using a small flat-tip screwdriver.

NOTE: Use care when adjusting the volume on the control unit to avoid damaging it.

