

PARTS LIST

Trailer Hitch Kit P/N 08L92-STK-200A

Trailer hitch

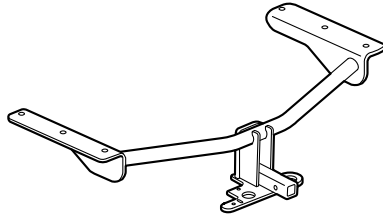

Ball mount

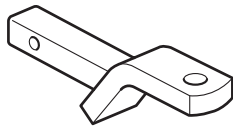

Right plate

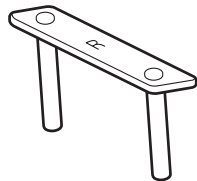

Left plate

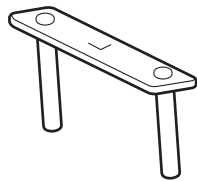

2 Bolts, 12 x 190 mm



2 Bolts, 12 x 175 mm



4 Nuts, 12 mm



10 Plain washers, 12 mm



6 Spring washers, 12 mm



2 Bolts, 12 x 40 mm

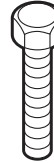

Hitch pin



Hitch pin clip



Receiver cover

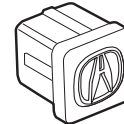

Trailer Hitch Harness Kit P/N 08L91-STK-200A

Control unit harness

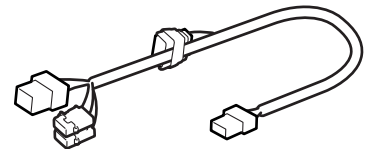

Socket harness

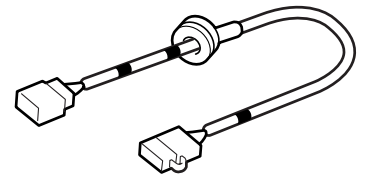

Control unit bracket

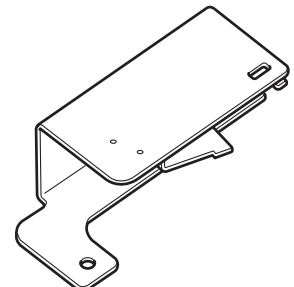

Control unit

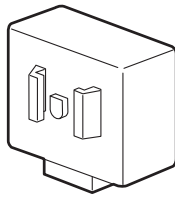

2 Jack nuts



Connector bracket

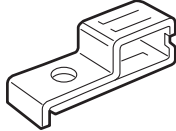

Fuse label

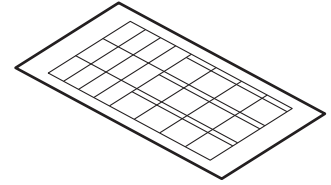

2 Flange bolts, 6 x 20 mm



Accessory User's Information Manual

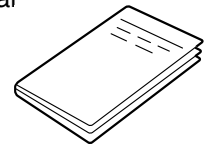

Flange bolt, 6 x 16 mm



TOOLS AND SUPPLIES REQUIRED

Flange nut 6 mm



Phillips screwdriver

Flat-tip screwdriver

Ratchet

5 mm, 6 mm, 10 mm, 12 mm, and 19 mm Sockets

Utility knife

Tape measure

Clip remover

Diagonal cutters

Scissors

Torque wrench

Drill

3 mm and 10 mm Drill bits

Blanket

Eye protection (safety goggles, face shield, etc.)

Isopropyl alcohol

Shop towel

Reciprocating saw (air saw) with 32 tpi blade (AT192A)

 Snap-on: AT192A or equivalent

Felt-tip pen

Duct tape

Pushpin

14 mm Wrench

5 Wire ties

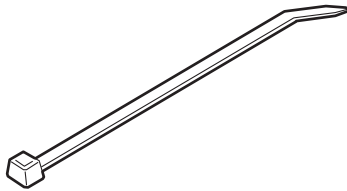

2 Wire ties with clips

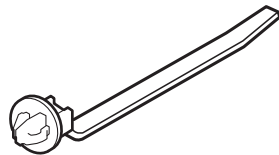

2 Connector clips



Illustration of the Trailer Hitch Installed on the Vehicle

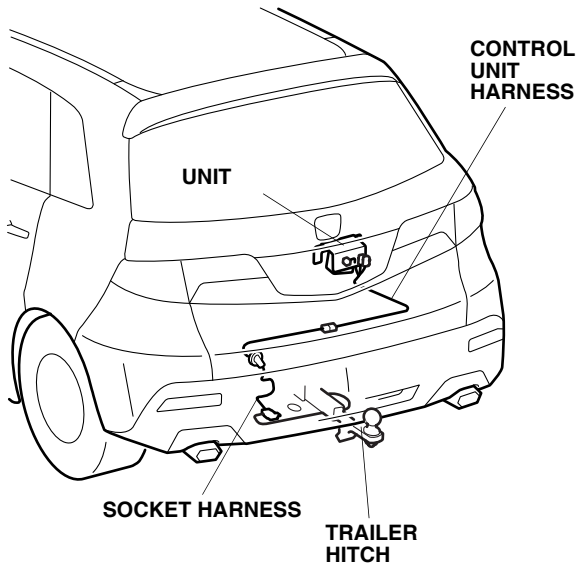

INSTALLATION

Client Information: The information in this installation instruction is intended for use only by skilled technicians who have the proper tools, equipment, and training to correctly and safely add equipment to your vehicle. These procedures should not be attempted by “do-it-yourselfers.”

NOTE:

- Be careful not to damage the rear bumper or other finished surfaces of the body.
 - Allow the exhaust system to cool down before installing the trailer hitch.
1. Make sure you have the anti-theft code for the radio, then write down the radio station presets.
 2. Disconnect the negative cable from the battery.

3. Open the tailgate. Remove the cargo area cover.

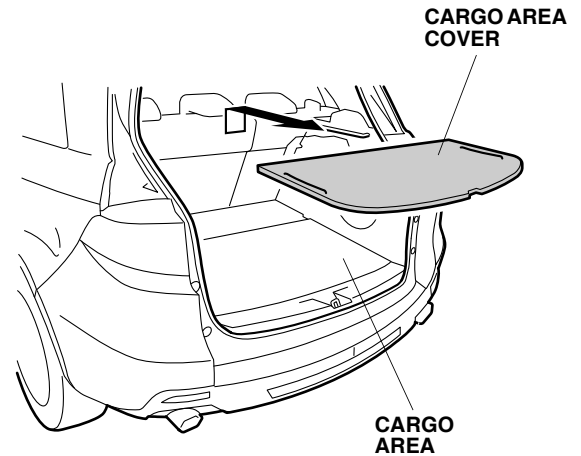

4. Remove the cargo area floor.

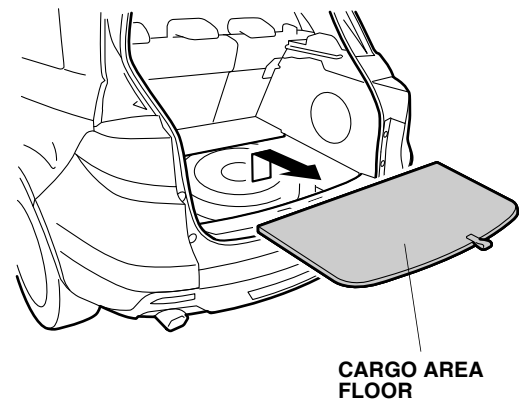

5. Remove the cargo area floor board (four clips).

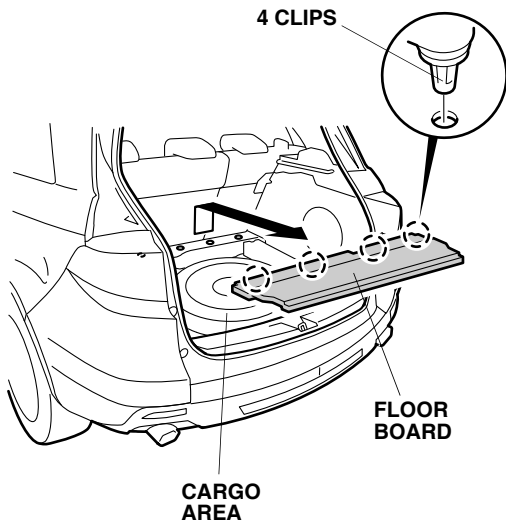

6. Pull away the weatherstrip, and remove the rear trim panel (two clips and four clips).

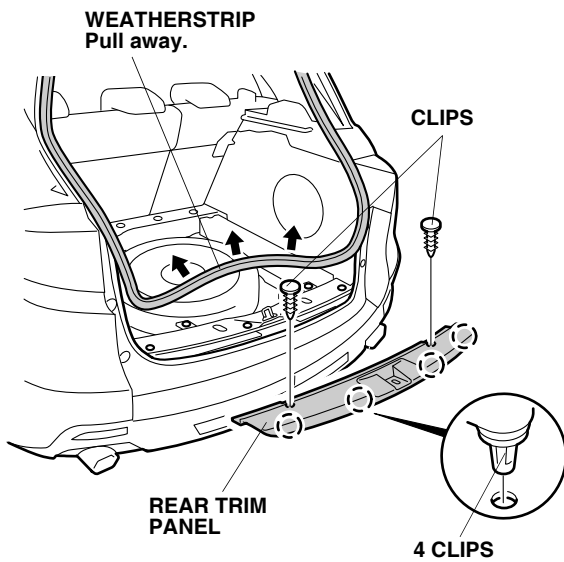

7. Fold the rear seat back forward.

8. Remove the spare tire (one anchor bolt).

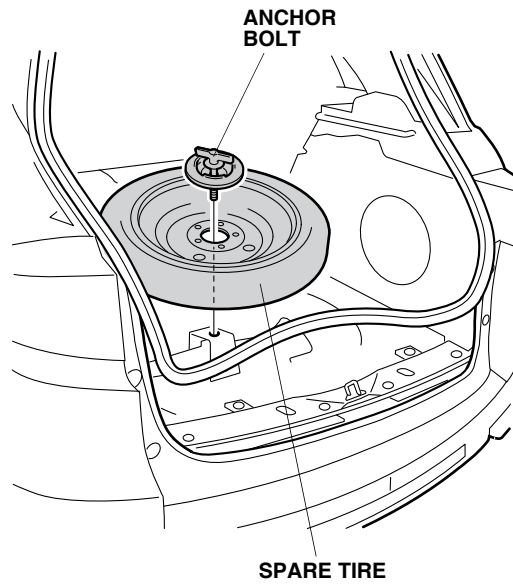

9. Remove the rear bumper (four caps, four bolts, four self-tapping screws, and four clips). Have an assistant help you when removing and installing the rear bumper. Place the rear bumper on a blanket after removal.

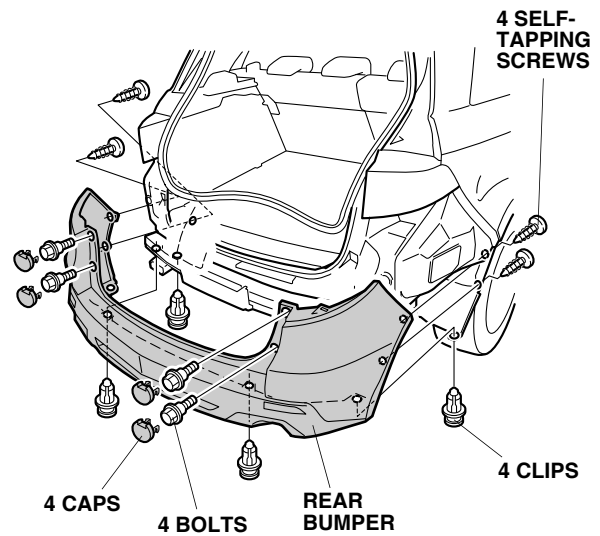

Installing the Trailer Hitch

10. While wearing eye protection, use an air saw to cut out the rear bumper along the scribe mark. Remove any burrs. Set the bumper aside on a blanket; it will be reinstalled later.

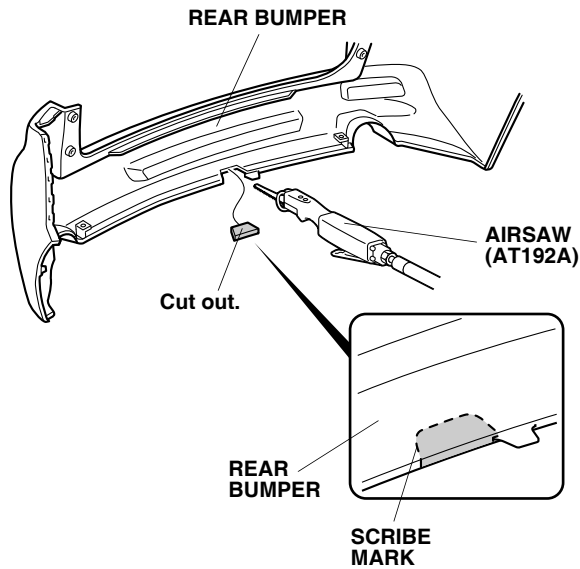

11. Inside the cargo area, locate the left spacer. Using a utility knife, cut out a section of the left spacer as shown.

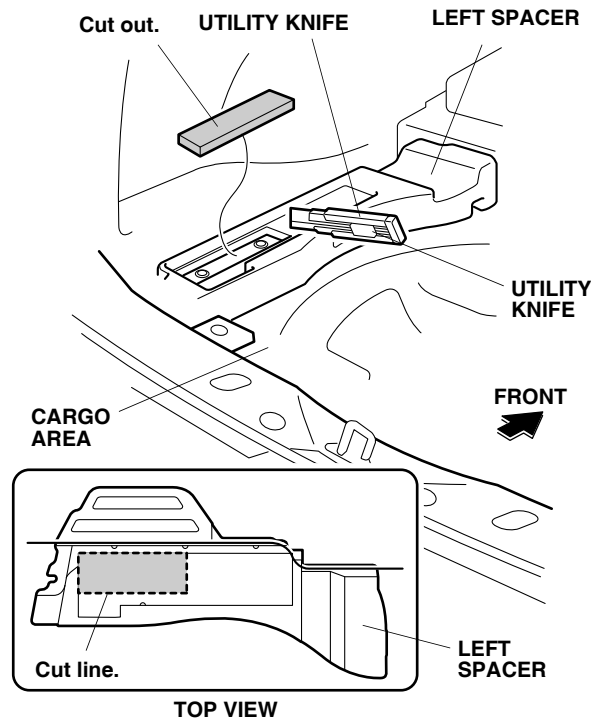

12. Locate the right spacer. Using a utility knife, cut out two sections of the right spacer as shown. Do not damage the vehicle harness under the right spacer.

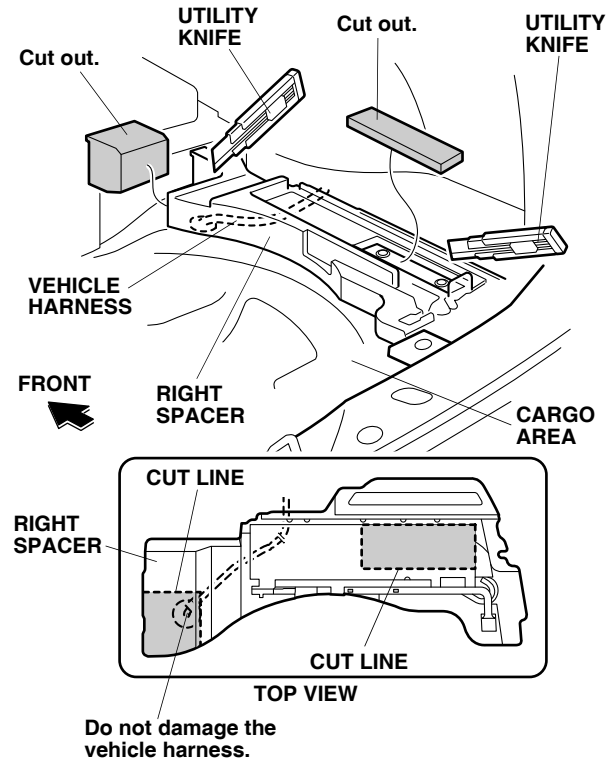

13. Remove the two clips that secure the right side trim panel and right floor spacer.

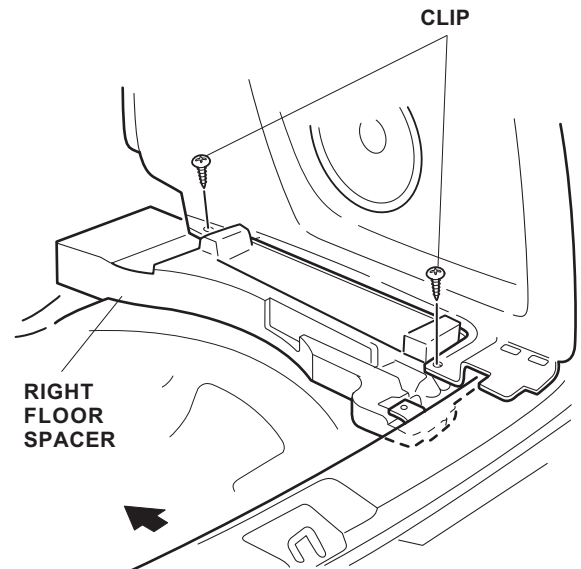

14. Remove the right floor spacer by gently pushing in at the back edge, and pulling out at the front edge to clear the vehicle bracket.

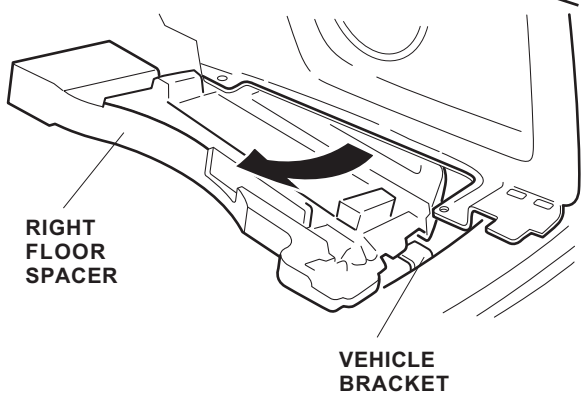
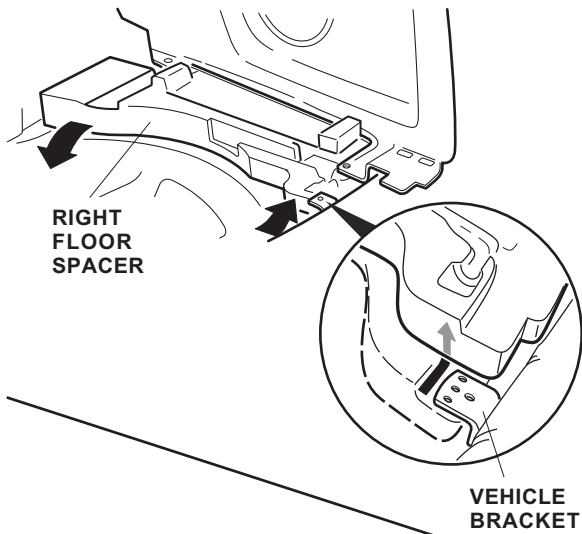

Routing the Trailer Hitch Harness

15. Inside the vehicle along the rear panel, locate the rubber grommet. Remove the rubber grommet by pushing it outward.

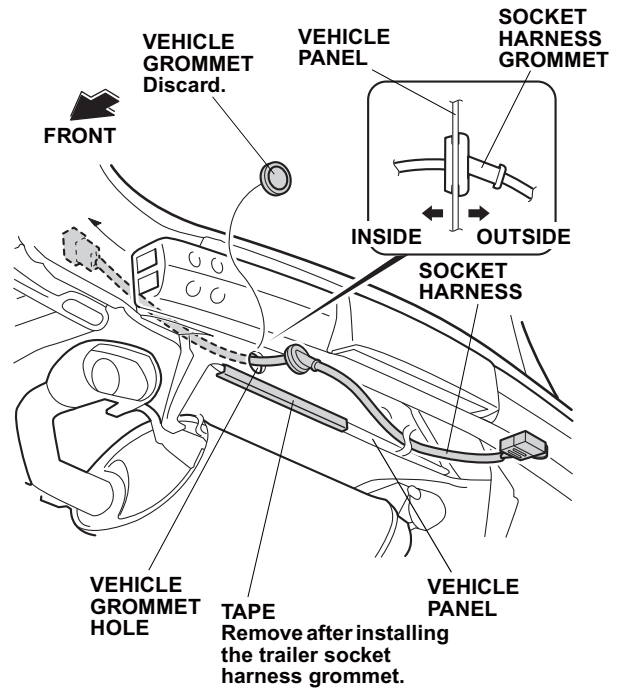
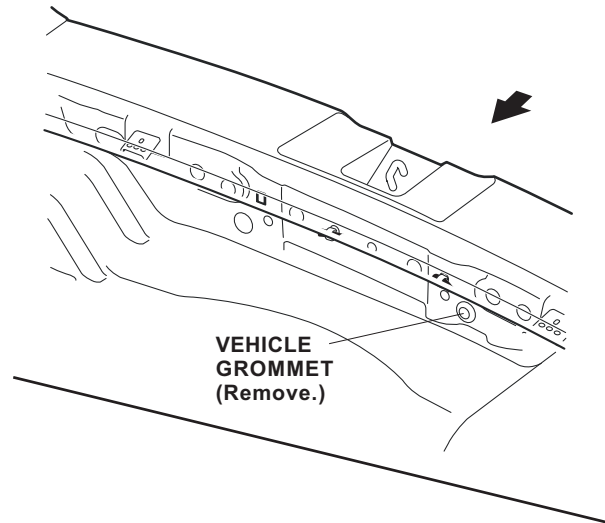

16. Under the grommet hole, attach a piece of masking tape to the vehicle panel in the area shown.
17. Get the socket harness, and route the socket harness inside of the vehicle. Seat the grommet in the panel hole in the direction shown.

- Install two wire ties with clips at the green-taped areas of the socket harness, then secure the socket harness to the vehicle panel.

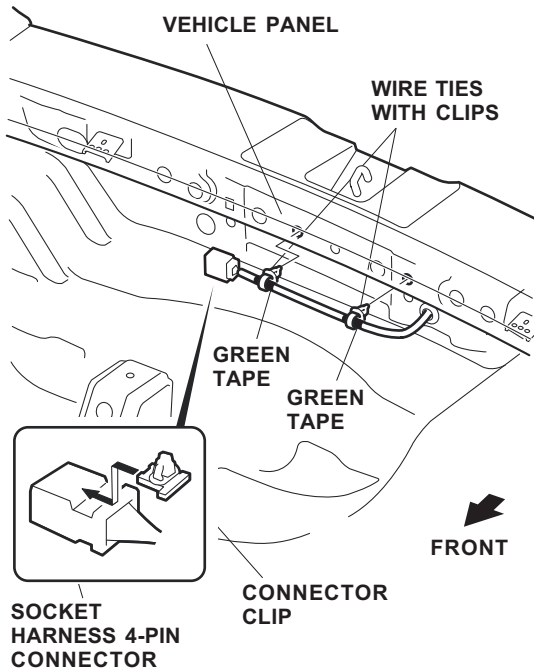

- Install the connector clip to the socket harness 4-pin connector, but don't clip the connector at this time.
- Get the control unit harness. Near the front of the cargo area, locate and remove the blue tape from the vehicle 6-pin connector. Plug the control unit harness 6-pin connector into the vehicle 6-pin connector.

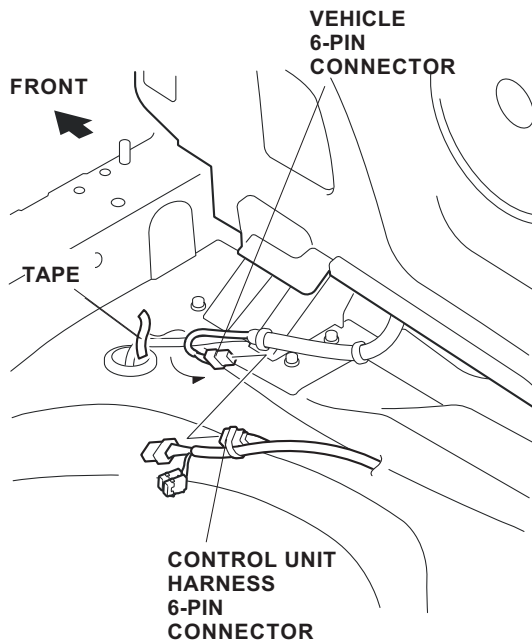

- Near the 6-pin connector, secure the control unit harness to the vehicle harness with two wire ties.

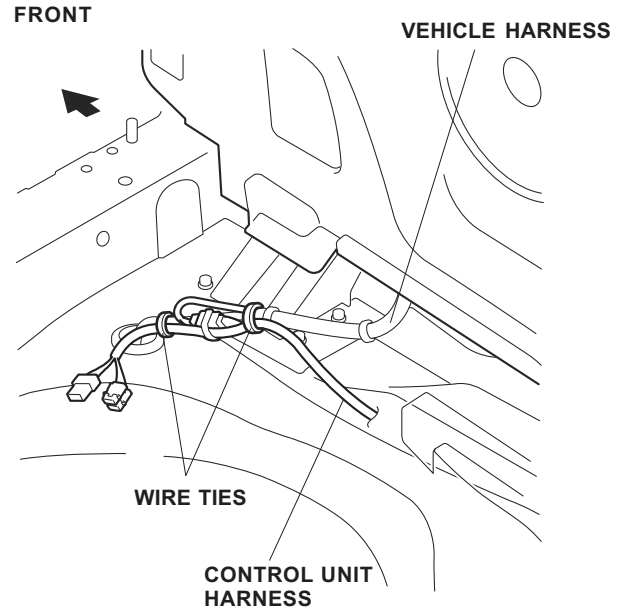

- Route the control unit harness towards the rear of the vehicle.
- Without Backup Sensors:** Using scissors, cut the two EPT sealers in half. Using isopropyl alcohol on a shop towel, clean the vehicle panel surface where the EPT sealer will attach. Secure the control unit harness to the vehicle using three halves of the EPT sealers. The remaining cut piece of EPT sealer will be used later.

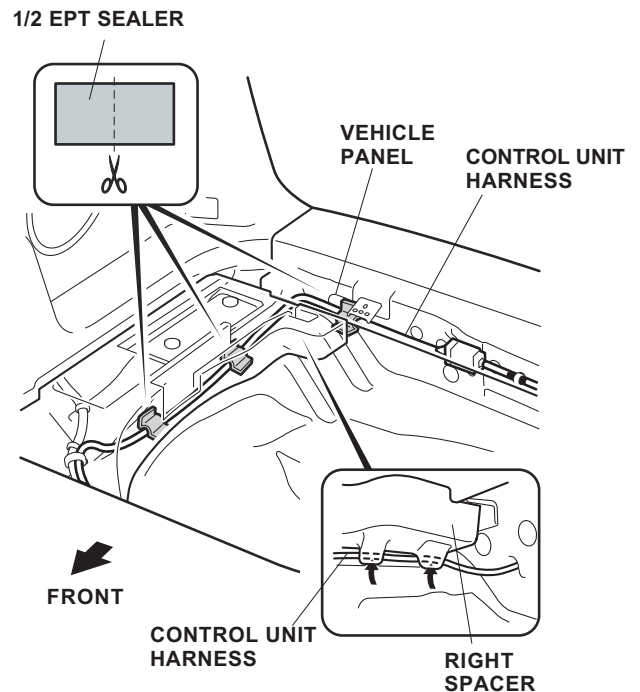

With Backup Sensors: Trim the corner of the right spacer to accommodate both wire harnesses.

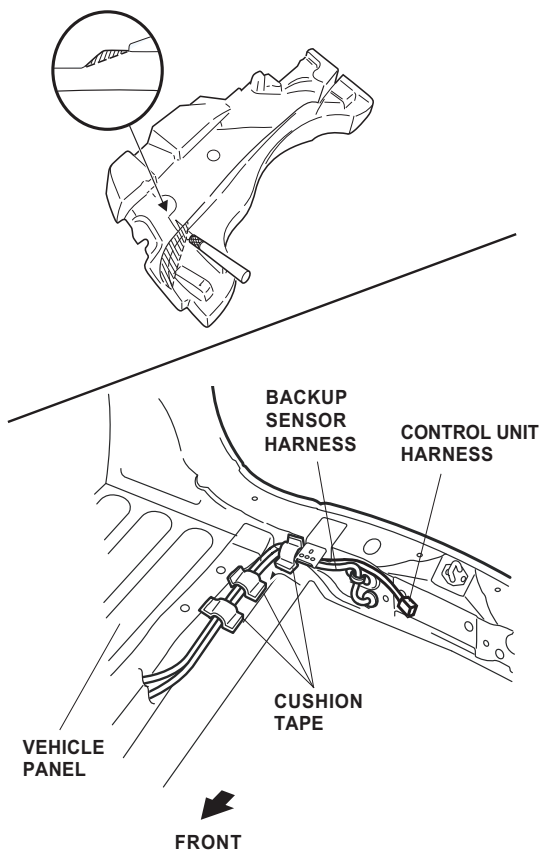

24. Plug the control unit harness 4-pin connector into the socket harness 4-pin connector.

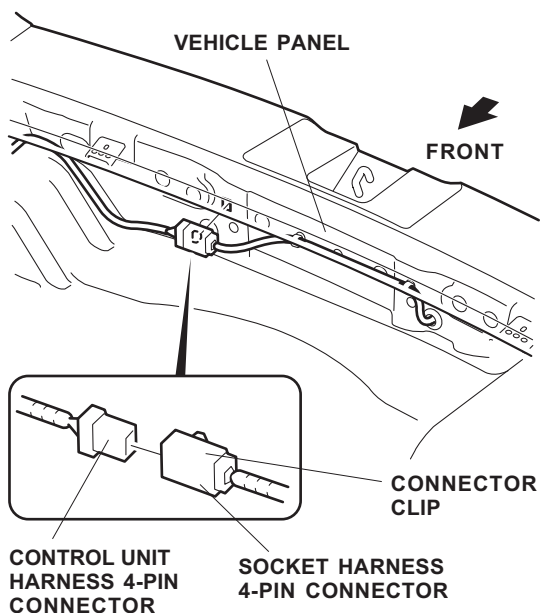

25. Secure the socket harness 4-pin connectors to the vehicle panel using the connector clip.

Installing the Control Unit

26. Install the two jack nuts into the vehicle panel holes. Using a 6 x 20 mm flange bolt, install each jack nut by tightening the flange bolt until the jack nut is collapsed. Remove the flange bolt.

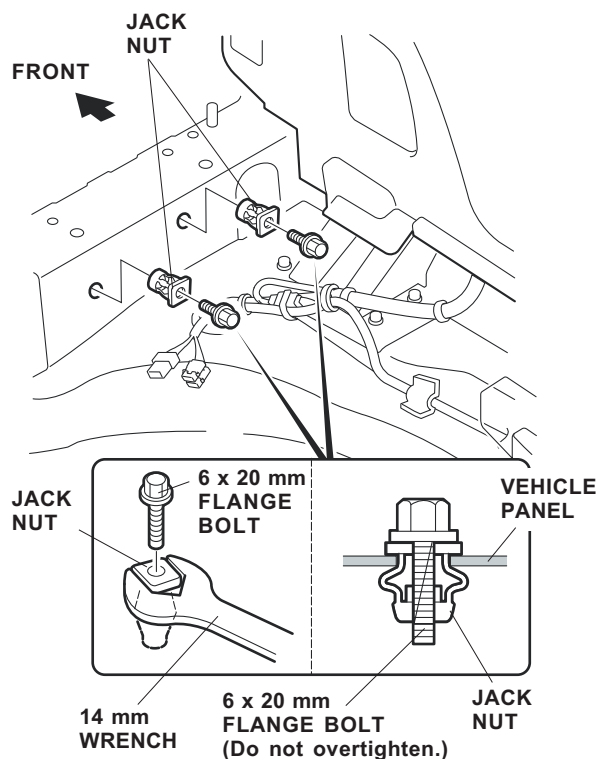

- Using isopropyl alcohol on a shop towel, clean the vehicle panel surface where the EPT sealer will attach. Attach the remaining cut piece of EPT sealer to the floor panel in the area shown.

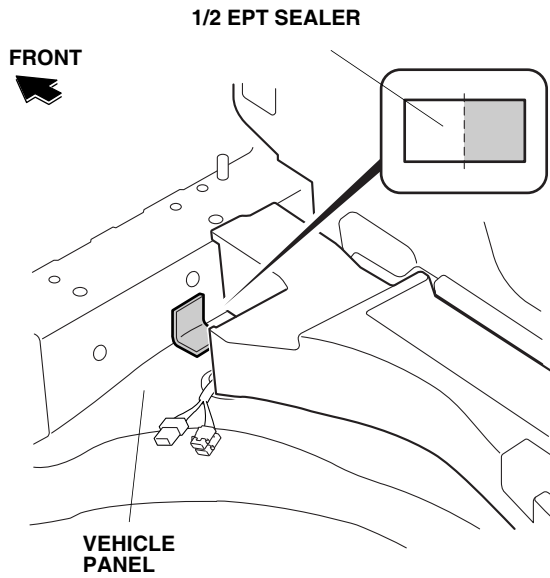

- Install the control unit bracket to the control unit.

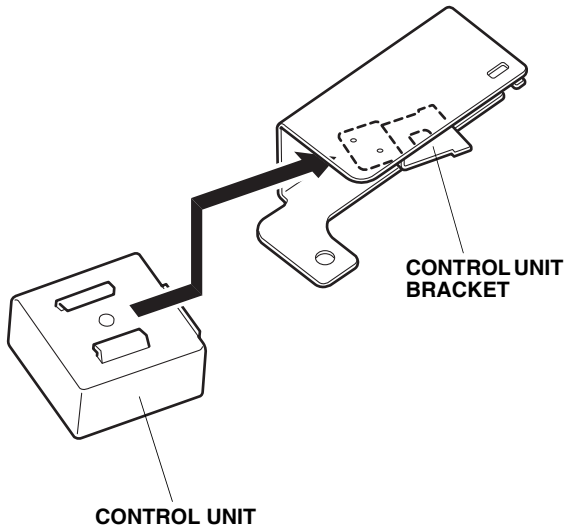

- Attach the 7.5A and 5A fuse labels to the fuse cases on the trailer hitch harness.

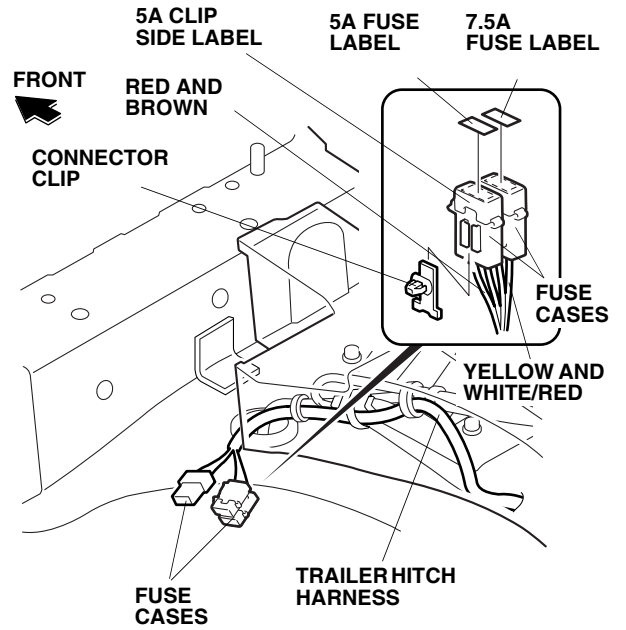

- Install the connector clip to the trailer hitch harness fuse case.
- Reinstall the right spacer.

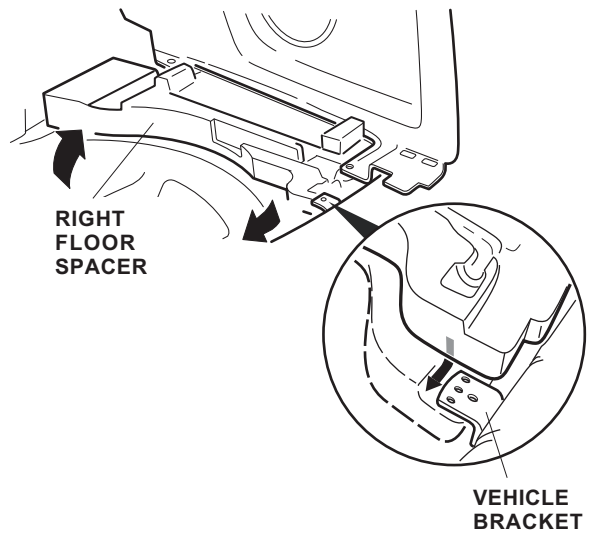

32. Loosely install one 6 x 20 mm flange bolt into the right jack nut.

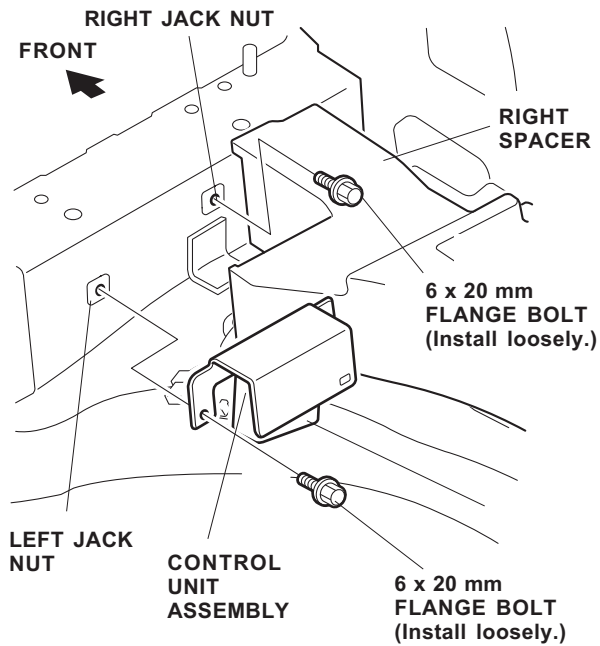

33. Attach the control unit bracket to the vehicle panel using one 6 x 20 mm flange bolt into the left jack nut. Do not tighten the flange bolt at this time.

34. Plug the control unit harness 12-pin connector into the control unit, and secure the fuse case connector clip to the bracket.

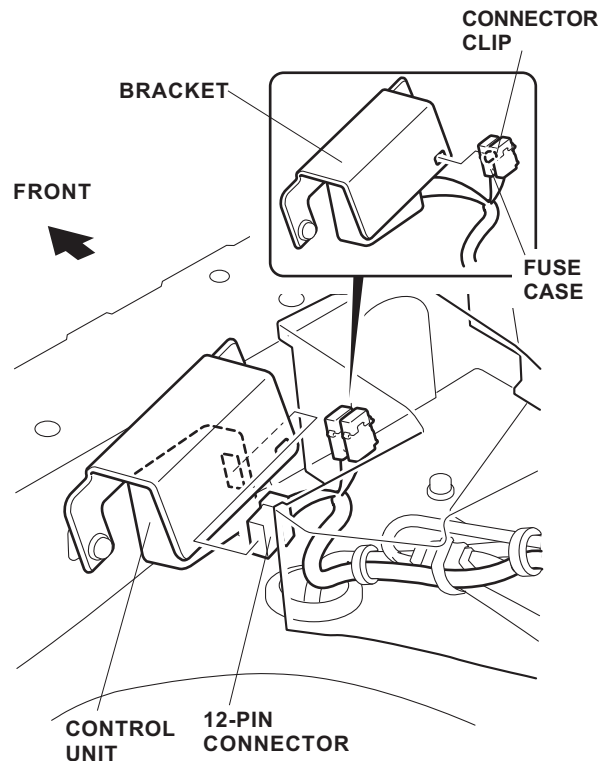

35. Rotate the control unit assembly down onto the right flange bolt. Torque both 6 x 20 mm flange bolts to 4.0 N·m (3.0 lb-ft).

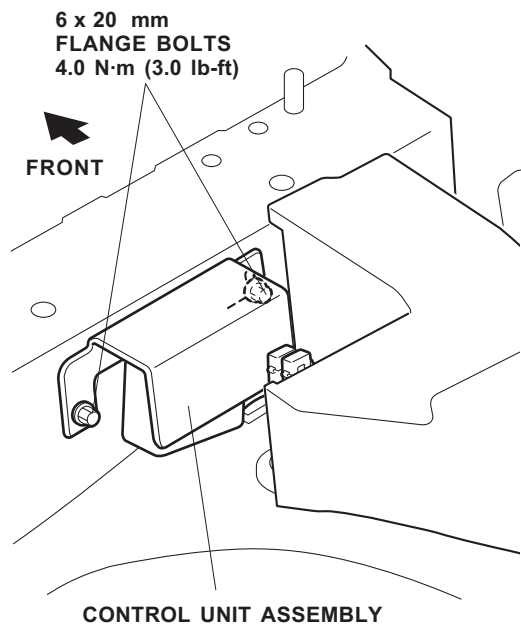

36. Check that all wire harnesses are routed properly, and all connectors are plugged in.

Installing the Trailer Hitch

37. Remove the four vehicle grommets from the vehicle.

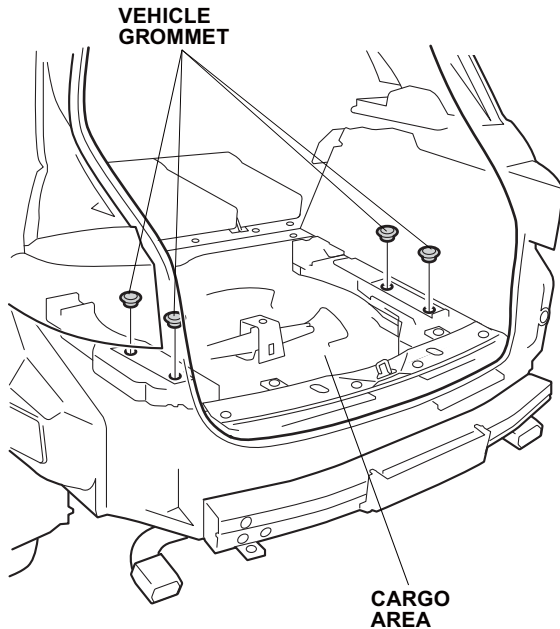

38. Insert the right and left plates into the holes exposed in step 37.

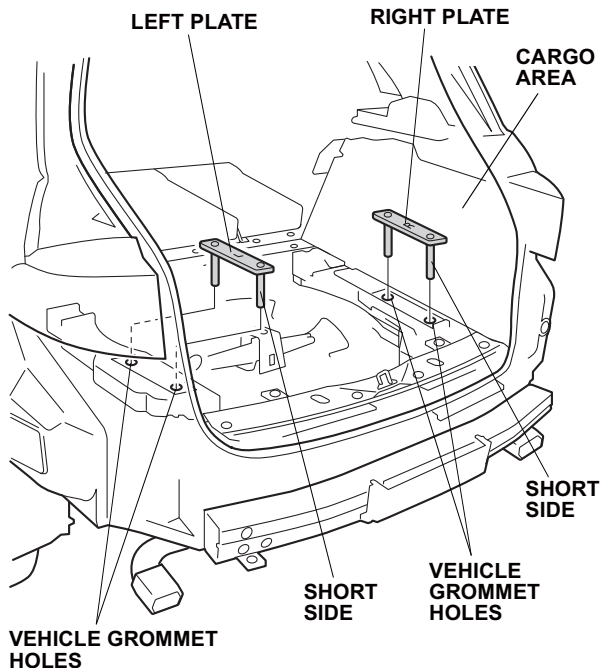

39. Install the trailer hitch with two 12 x 40 mm bolts with plain washers and lock washers, but do not tighten the bolts yet.

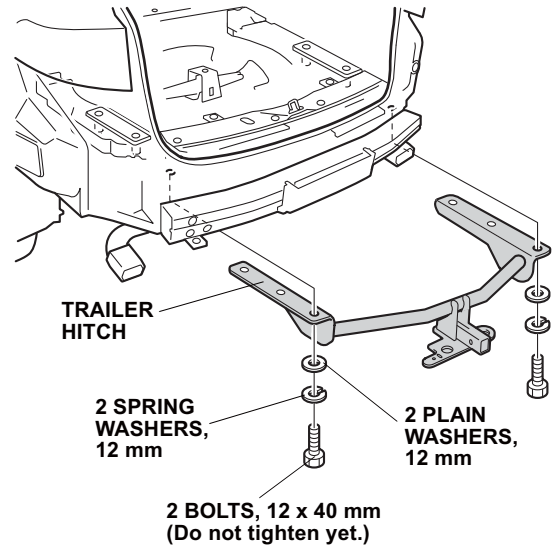

40. Loosely secure the trailer hitch on the right and left plates using eight plain washers, four lock washers, four nuts, two 12 x 190 mm bolts, and two 12 x 175 mm bolts. Torque (12 x 190 mm bolt and 12 x 175 mm bolt): 79 N·m (58 lb·ft).

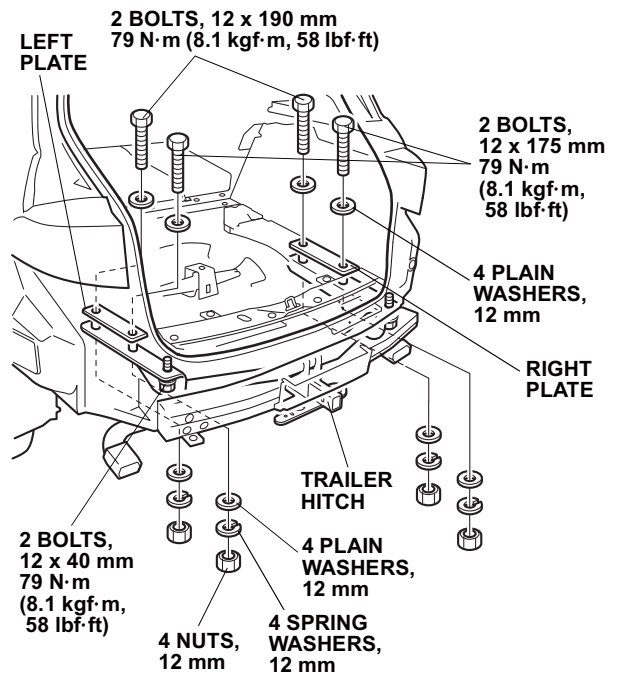

41. Torque the 12 x 40 mm bolts installed in step 39 to 79 N·m (58 lb·ft).

42. Route the socket harness (installed in step 17) along the trailer hitch using two wire ties.

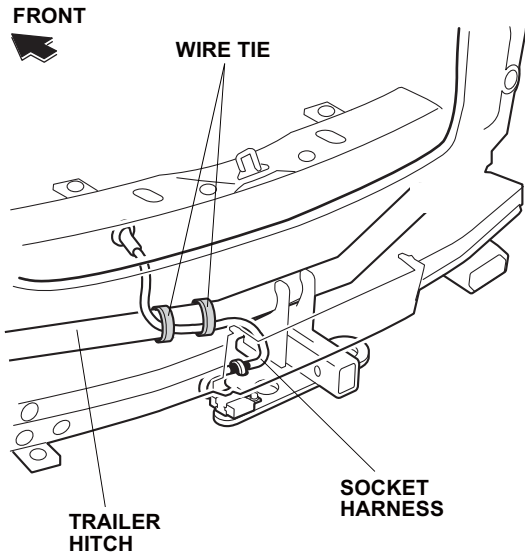

43. Attach the socket harness 4-pin connector to the trailer hitch using the connector bracket, the 6 x 16 mm flange bolt and the 6 mm flange nut.

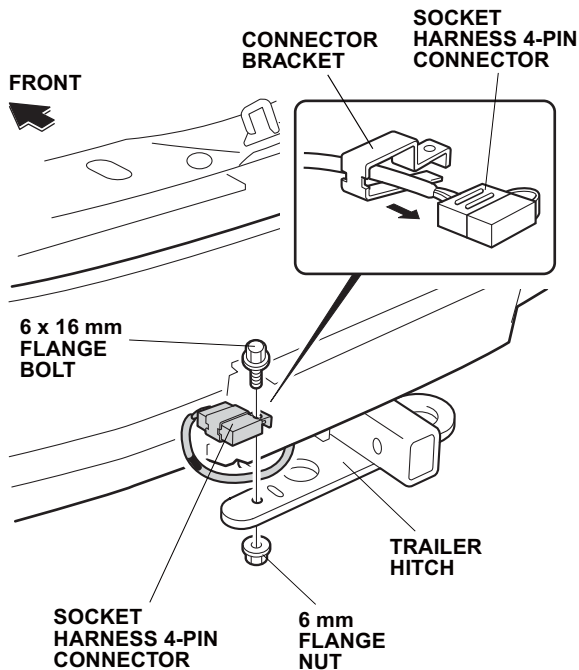

44. Secure the socket harness to the trailer hitch at the black tape using one wire tie.

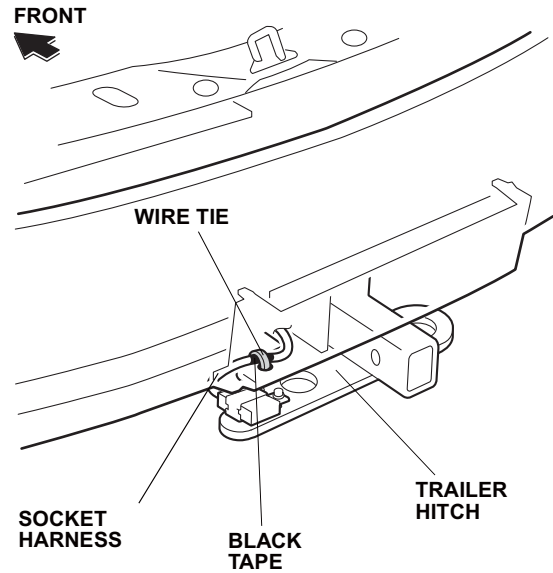

45. Check that all wire harnesses are routed properly and all connectors are plugged in.
 46. Reinstall all removed parts.
 47. Reconnect the negative cable to the battery.
 48. Enter the client's radio anti-theft code, and reset the radio station presets.
 49. Reset the clock.

NOTE: Whenever the battery is disconnected, the driver's window AUTO function is disabled.

- Start the engine. Push down on the driver's window switch until the window is fully open.
- Pull up on the driver's window switch to close the window completely, then hold the switch for 2 seconds or more.
- Lower and raise the window to check the operation of the driver's window AUTO function.

Installing the Receiver Cover

Whenever you remove the hitch pin clip, the hitch pin, and the ball mount, store them securely in the cargo area. Install the receiver cover into the opening at the end of the trailer hitch. When you reinstall the ball mount, store the receiver cover in the cargo area. After the first 600 miles (1,000 km) of towing, have your Acura dealer recheck the tightness of the trailer hitch bolts.

FRONT

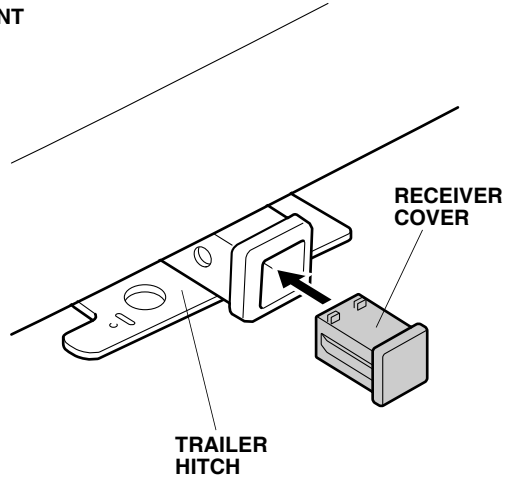

Install the ball mount on the trailer hitch using a hitch pin clip and hitch pin.

