

# ACURA INSTALLATION INSTRUCTIONS

Accessory	Application	Publications No.
<b>ENGINE BLOCK HEATER P/N 08T44-SNA-101</b>	<b>2012 RDX</b>	<b>BII 46127</b>
		Issue Date
		<b>AUG 2011</b>

## PARTS LIST

NOTE: Installation of the engine block heater requires that the vehicle be raised on a hoist and that the coolant be replaced. This installation should be done only by an authorized dealer.

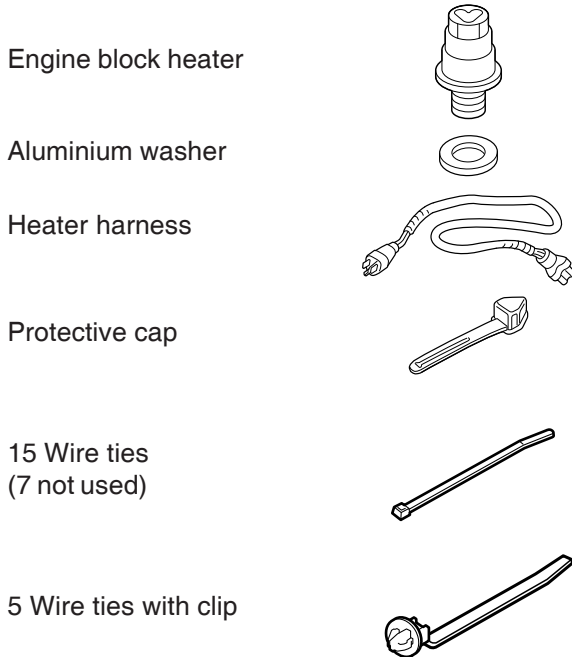

## TOOLS AND SUPPLIES REQUIRED

- Philips screwdriver
- Flat-tip screwdriver
- Ratchet
- 19 mm and 24 mm Sockets
- Torque wrench
- Drill
- Drill bit (3 mm, 5 mm)
- Wrench (1/2 inch)
- 10 mm Combination wrench
- Diagonal cutters
- Drain pan
- Coolant (Acura Precision Crafted Antifreeze/Coolant only, in a 50/50 mixture with water)
- Blanket/Fender cover
- Tape measure

## NOTE:

- Always use Acura Antifreeze/Coolant. Using a non-Acura coolant can result in corrosion, causing the cooling system to malfunction or fail.
- To avoid burning out the element, do not operate the engine block heater until it is installed in the vehicle and you have added coolant.

## INSTALLATION

**Client Information:** The information in this installation instruction is intended for use only by skilled technicians who have the proper tools, equipment, and training to correctly and safely add equipment to your vehicle. These procedures should not be attempted by “do-it-yourselfers.”

1. Make sure you have the anti-theft code for the audio unit and navigation system, then write down the radio presets.
2. Open the hood, and allow the engine and all cooling system components to cool down.
3. Place a clean drain pan under the radiator drain plug, then remove the drain plug from the bottom of the radiator to drain the coolant. Remove the radiator cap to increase the flow.

### NOTICE

Radiator coolant will damage paint. Quickly rinse any spilled coolant from painted surfaces.

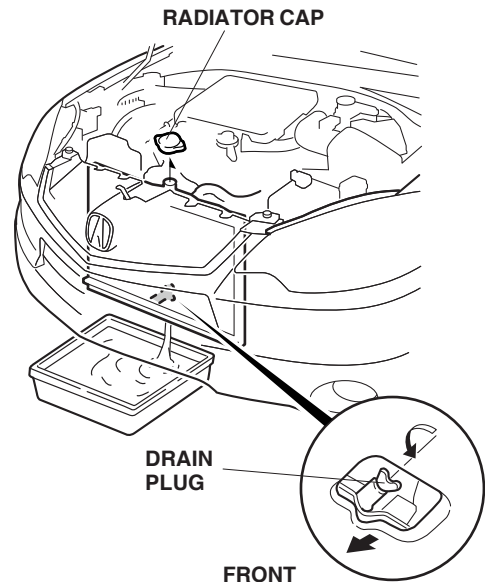

- Remove the four clips and two long clips from the front bulkhead cover.

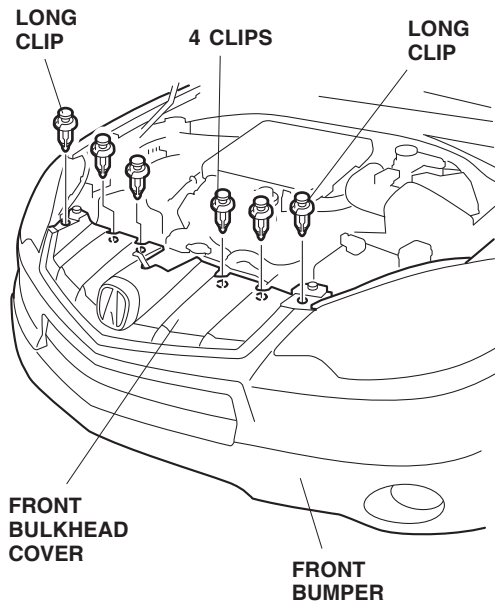

- Remove the front bumper (six self-tapping screws, three clips, four long clips, and unplug the fog light connectors).

- Have an assistant help you when removing and installing the front bumper.
- Place the front bumper on a blanket/fender cover to prevent damage.

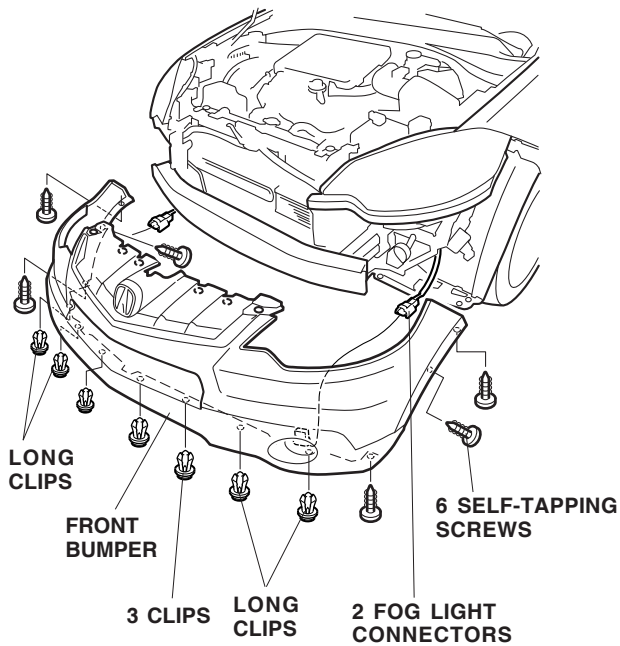

- Remove the air duct cover (two clips and one pin).

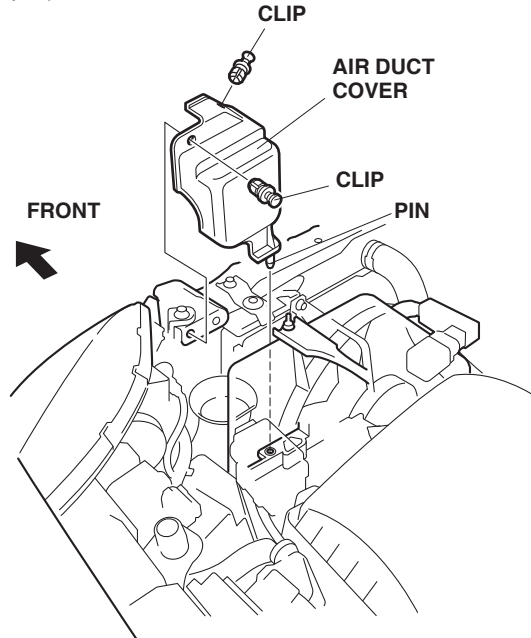

- Disconnect the negative (-) cable from the battery, open the positive cable cover and disconnect the positive (+) cable from the battery. Loosen the two battery holder nuts and remove the battery holder.

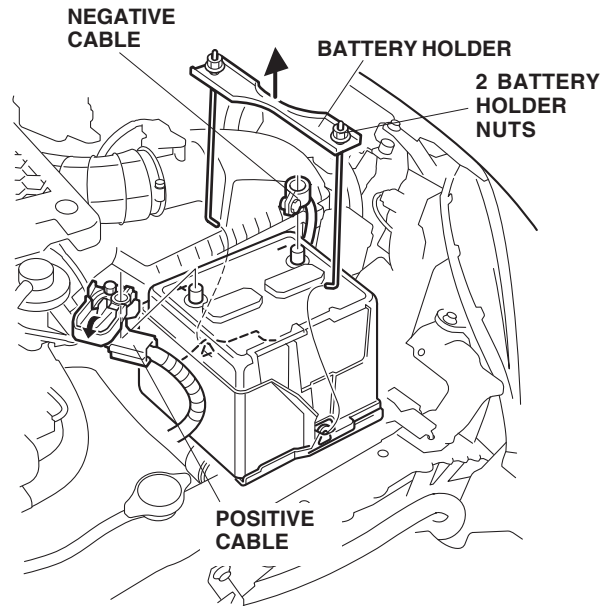

- Remove the battery cover, battery, and battery box.

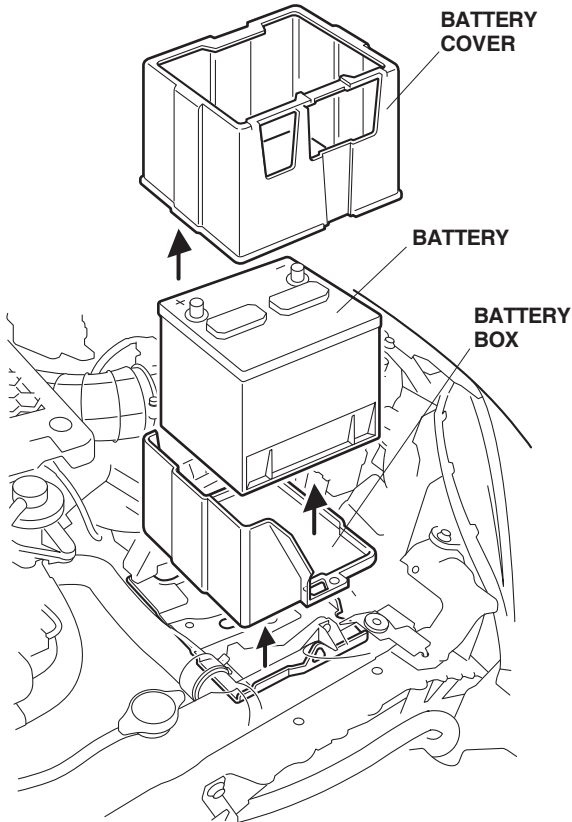

- Remove the vehicle harness from the vehicle brackets (two retaining tabs).

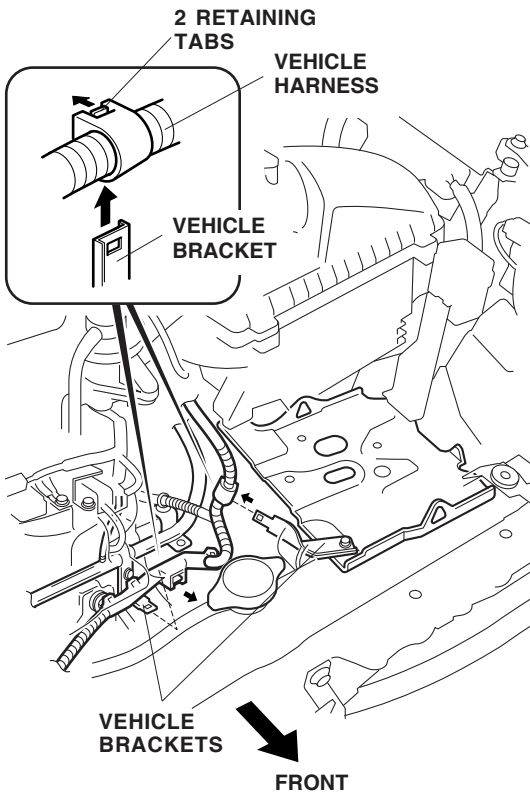

- Remove the vehicle bracket from the battery tray (one vehicle bolt).

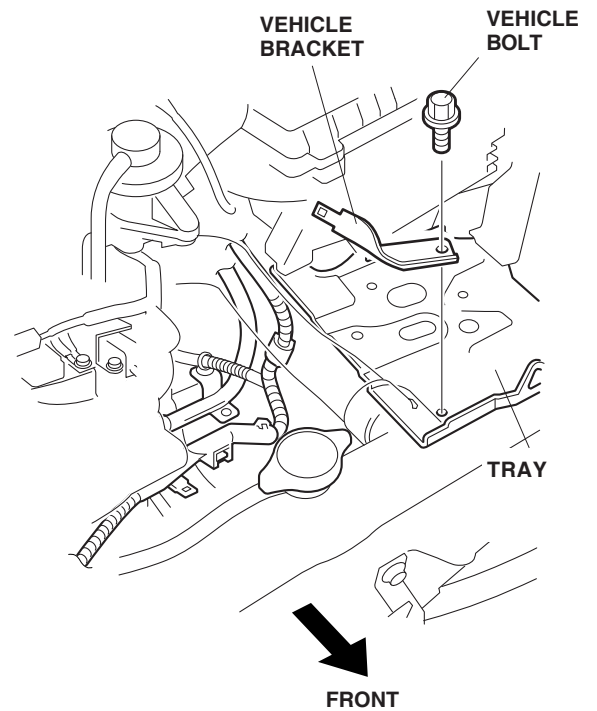

- Locate and remove the engine block drain bolt and washer. Coolant remaining in the engine jackets flows out of the bolt hole when the bolt is removed. (Retain the bolt and washer in case the block heater is removed.)

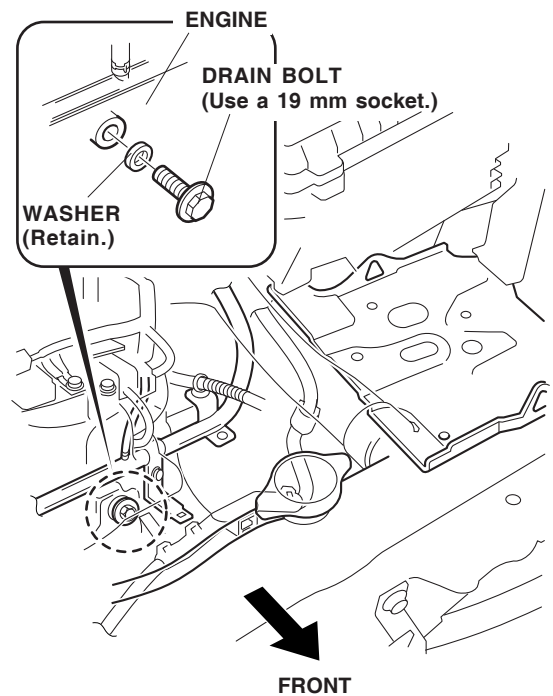

- Install the aluminum washer and the engine block heater into the bolt hole using a 24 mm socket and torque wrench. Torque the engine block heater to 60 N·m (44 lbf-ft).

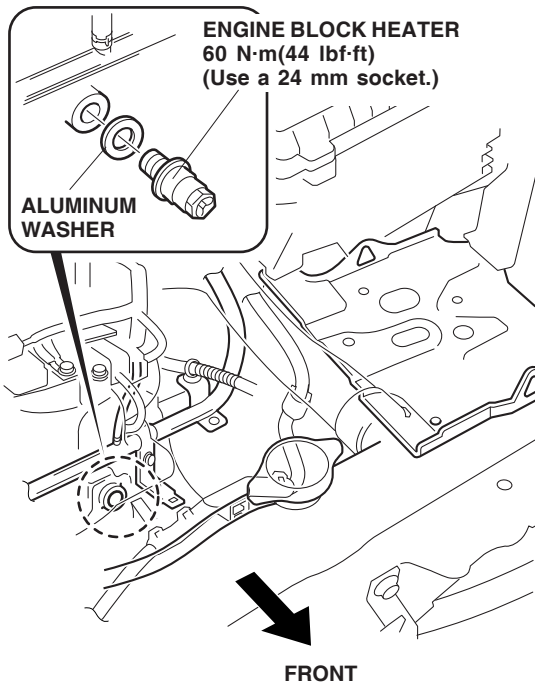

- Install five wire ties with clips to the heater harness at the measurements shown.

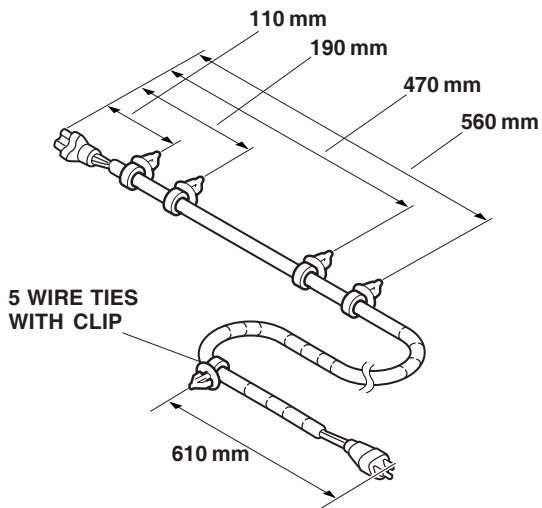

- Plug the heater harness connector into the engine block heater.

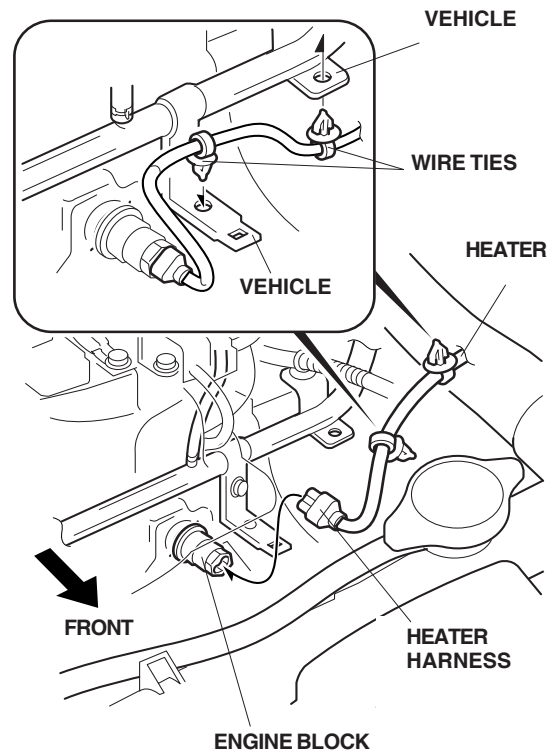

- Attach the first and second wire ties with clips to the vehicle brackets.

- Attach the third and the fourth wire ties with clips to the two holes under the battery tray.

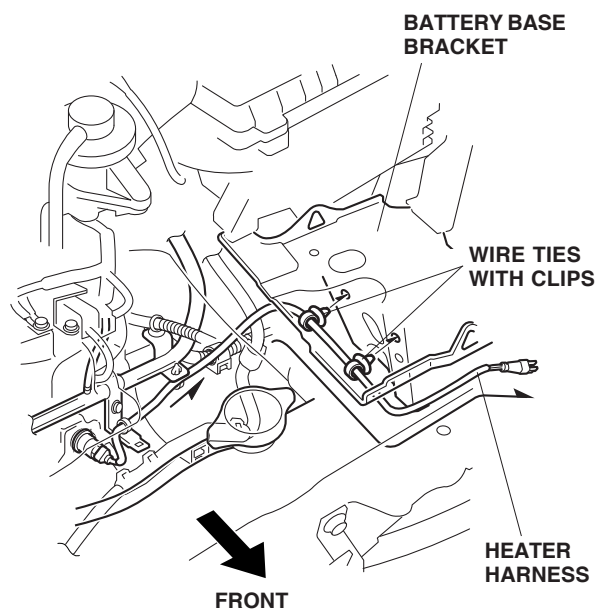

- Route the heater harness through the front bulkhead opening.

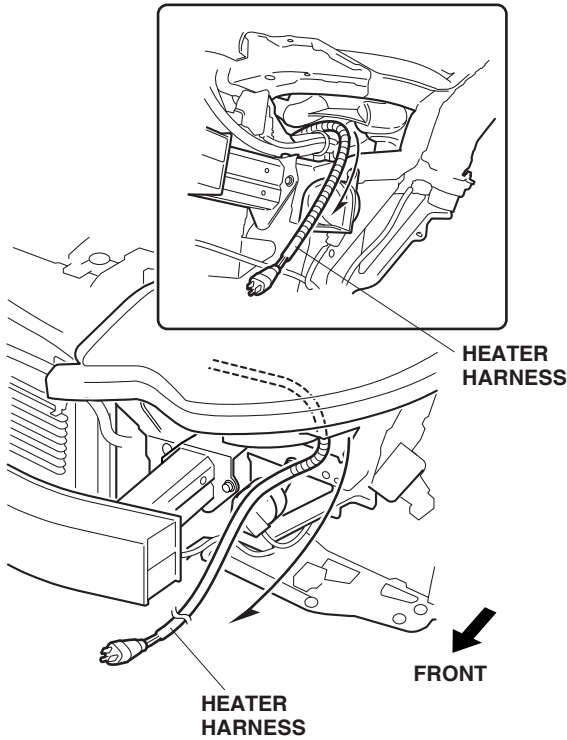

- Secure the fifth wire tie with clip to the vehicle frame.

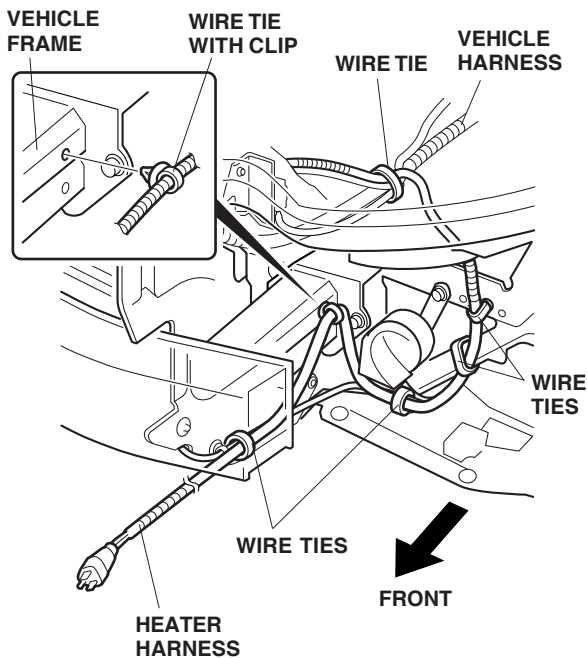

- Secure the heater harness to the vehicle harness and the vehicle frame using five additional wire ties.
- Near the engine block heater, secure the heater harness to the vehicle harness with one additional wire tie.

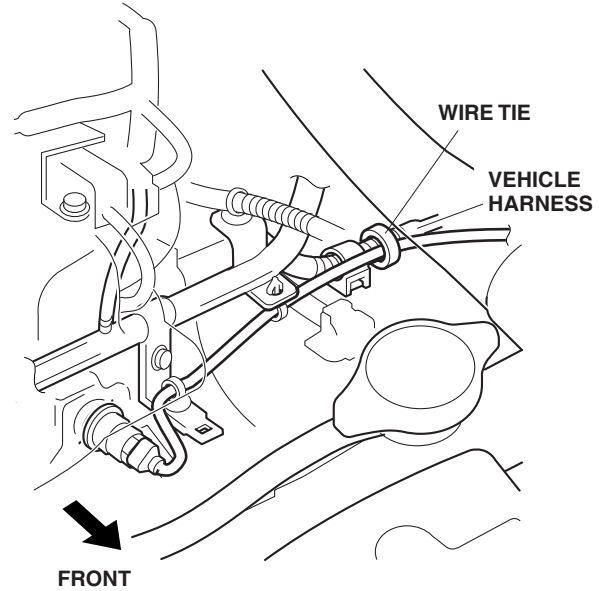

- On the inside of the front bumper, locate the two marks. While wearing eye protection, drill two 5 mm holes through the marked points on the front bumper lower grille. First drill with a 3 mm drill bit, and finish with a 5 mm drill bit.

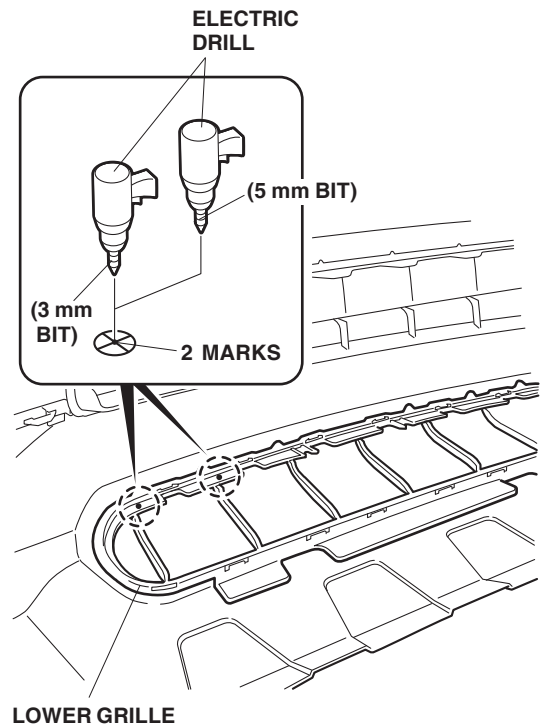

22. Reinstall the front bumper on the vehicle. Secure the heater harness to the front bumper lower grille using two wire ties through the holes drilled in step 21.

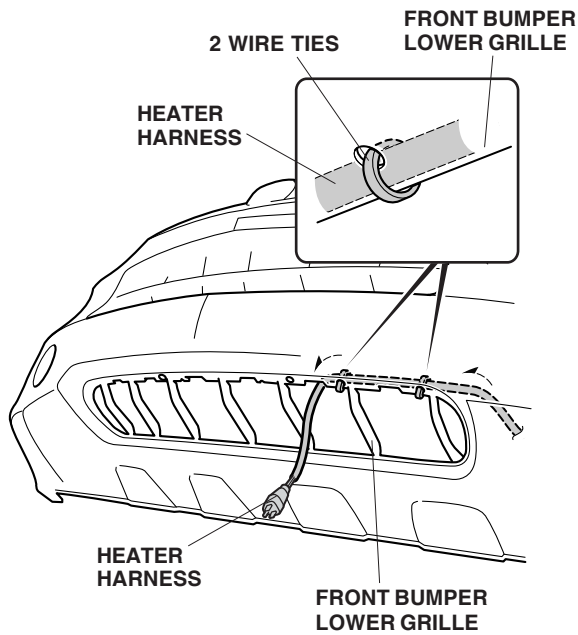

23. Attach the protective cap to the front bumper lower grille, and plug the heater harness connector into the protective cap.

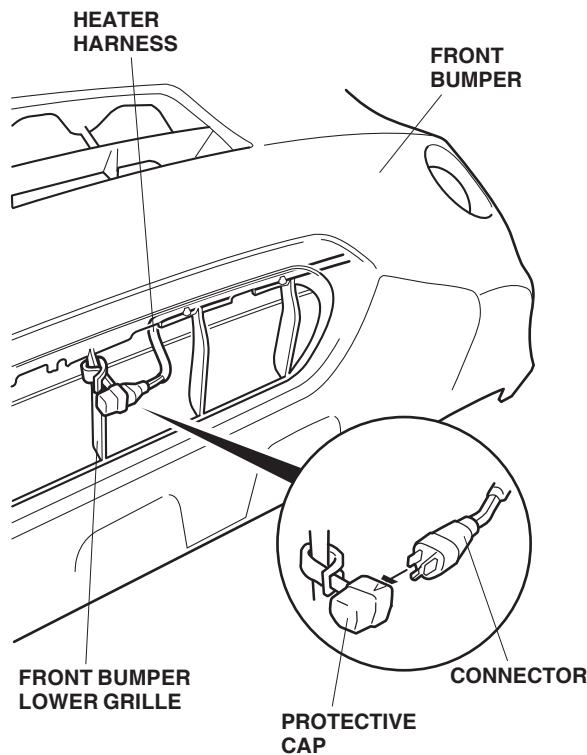

24. Reinstall all removed parts.
25. Reinstall the radiator drain plug.
26. Fill the system with the recommended coolant. Follow the instructions described in the service manual to fill and bleed the cooling system.
27. Check the coolant reservoir for correct level and check the cooling system for signs of leakage. Repair as necessary.
28. Check that the heater harness is routed properly and all connectors are plugged in.
29. Put the drain bolt (removed in step 11) in the glove box.
30. Reconnect the negative cable to the battery.
31. Enter the client's radio anti-theft code, and reset the radio station presets.
32. Reset the clock.

NOTE: When the battery is disconnected, the driver's window AUTO function is disabled.

- Start the engine. Push down on the driver's window switch until the window is fully open.
- Pull up on the driver's window switch to close the window completely, then hold the switch for 2 seconds or more.
- Lower and raise the driver's window to check operation of the driver's window AUTO function.