



INSTALLATION INSTRUCTIONS

Accessory
SPORT RUNNING BOARDS
P/N 08L33-SZN-200

Application
2011 ZDX

Publications No.
BII 45339
Issue Date
DEC 2010

PARTS LIST

2 Sport running boards

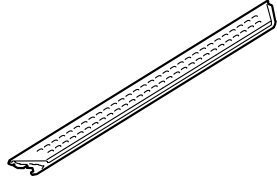

Left center trim

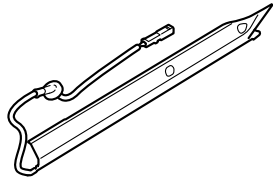

Right center trim

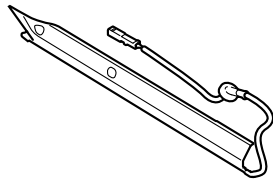

Left under cover

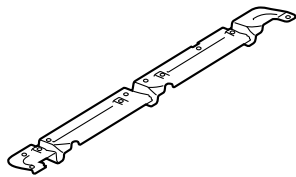

Right under cover

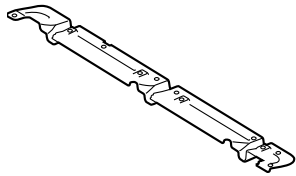

Left front end cap

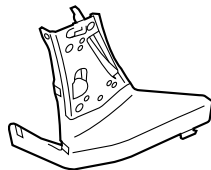

Right front end cap

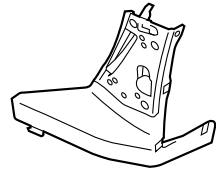

Left rear end cap

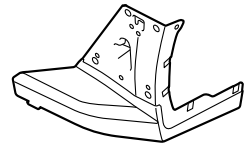

Right rear end cap

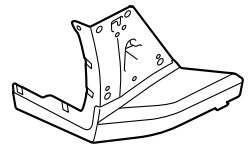

Left bracket A

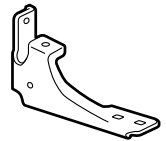

Right bracket A

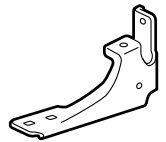

2 Left brackets B

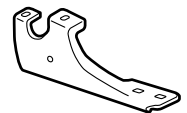

2 Right brackets B

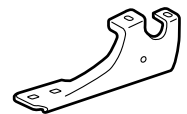

12 Flange bolts, 8 x 20 mm

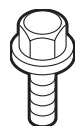

14 Square head bolts



14 Flange nuts



2 EPT sealers

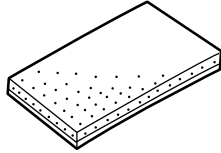

4 Wire ties

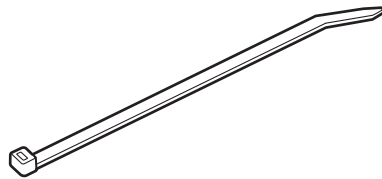

12 Push nuts



8 Self-tapping screws



8 Spring nuts



4 Clip nuts

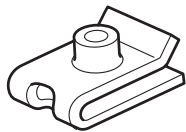

4 Bolts

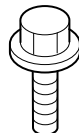

TOOLS AND SUPPLIES REQUIRED

Phillips screwdriver

Stubby phillips screwdriver

Torque wrench

8 mm, 10 mm, and 13 mm Sockets

10 mm Wrench

Plastic trim tool

T/N SILTRIMTL10

Isopropyl alcohol

Shop towel

Needle-nose pliers

Ratchet

Scissors

Diagonal cutters

Illustration of the Sport Running Boards on the Vehicle

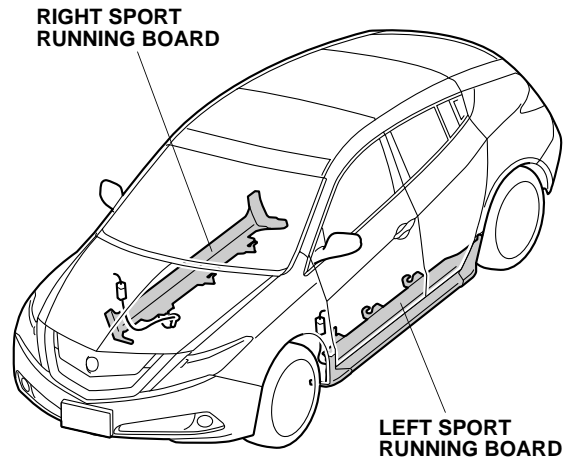

INSTALLATION

Client Information: The information in this installation instruction is intended for use only by skilled technicians who have the proper tools, equipment, and training to correctly and safely add equipment to your vehicle. These procedures should not be attempted by “do-it-yourselfers.”

NOTE:

- Do not damage the body paint finish.
- Clean and wax the area to be covered with a high quality paste wax.
- Before removing parts from the vehicle, note their locations and how they are installed so they can be reinstalled in the original positions.

1. Make sure you have the anti-theft code for the audio unit and the navigation system if equipped, then write down the radio station presets.
2. Disconnect the negative cable from the battery.

Removing the Vehicle Parts

3. Remove five self-tapping screws that secure the left rear inner fender.

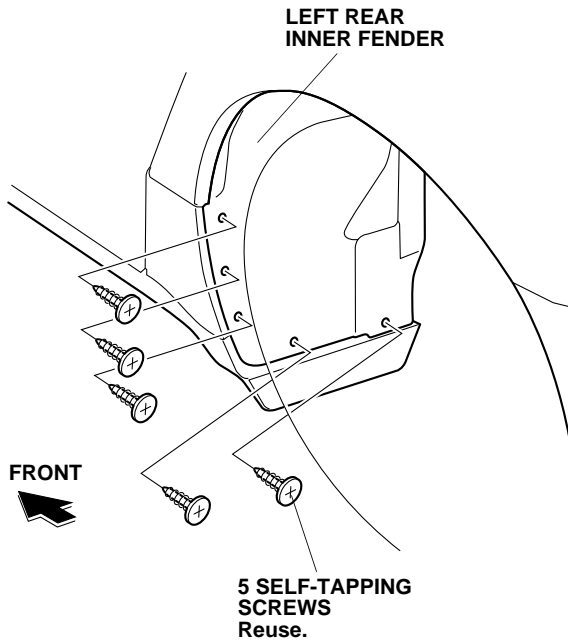

4. Remove the four spring nuts shown.

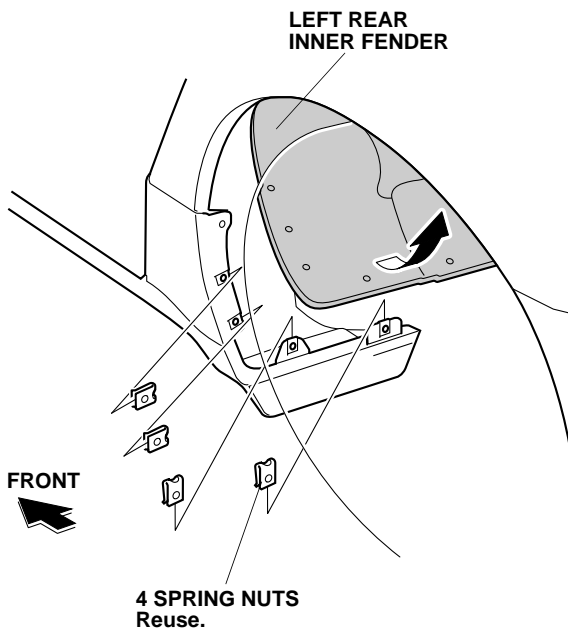

5. Under the vehicle, remove three bolts shown.

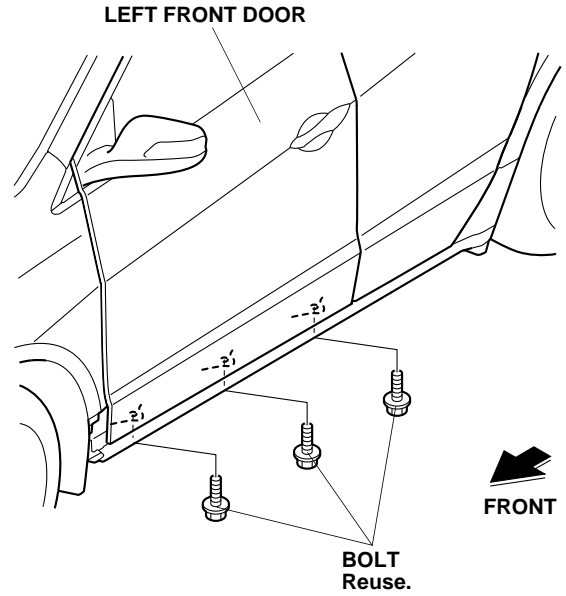

6. Open the left front door and left rear door.
7. Remove the left front side sill trim (four self-tapping screws and three clips).

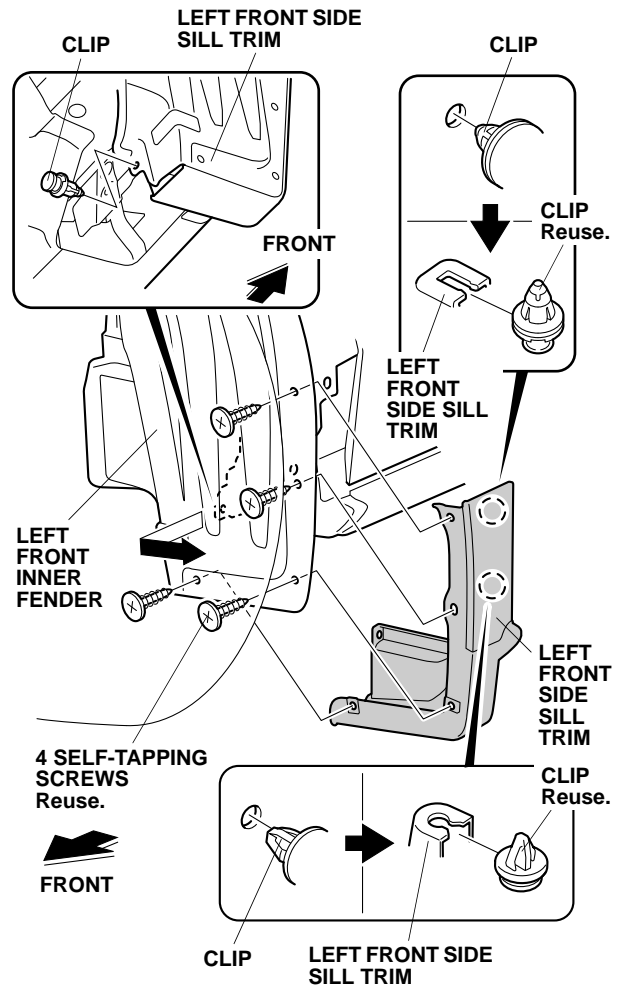

- Remove the two spring nuts from the front side sill trim.

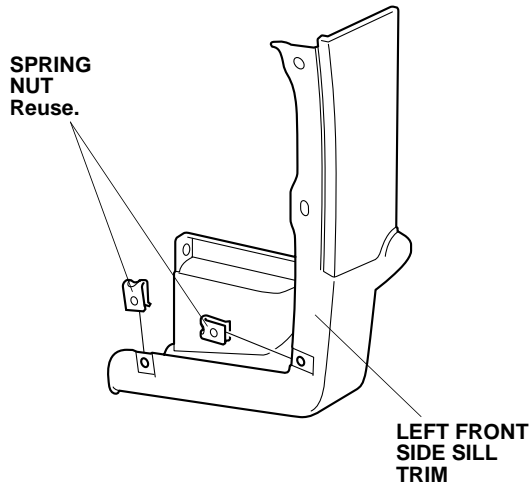

- Cut off four pins on the left front side sill trim cover as shown and remove the left front side sill trim cover (one self-tapping screw).

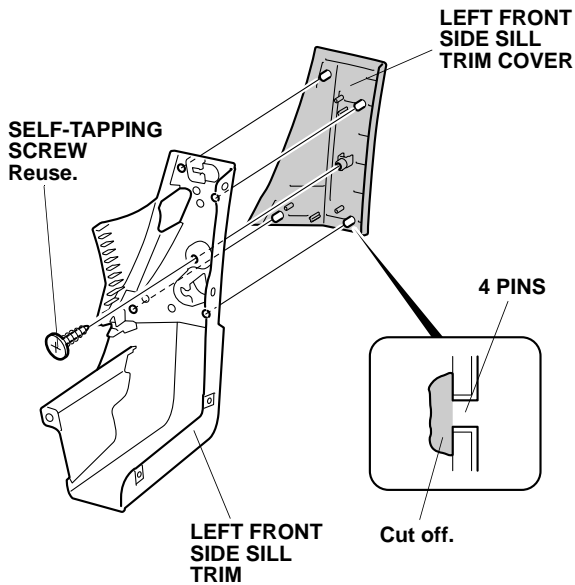

- Using a plastic trim tool, release the rear of the left rear side sill trim (one clip) and remove the clip from the left rear side sill trim.

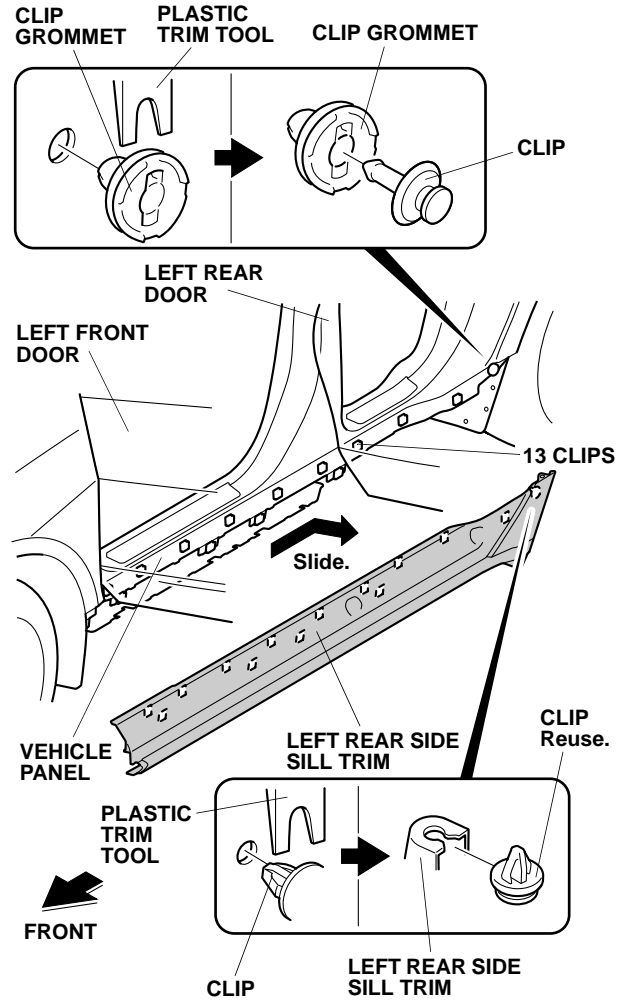

- Remove the left rear side sill trim (thirteen clips).
- Using a plastic trim tool, remove one clip grommet. Install the clip removed in step 10 to the clip grommet.

13. Using diagonal cutters, cut off the four pins from the left rear side sill trim cover. Remove the left rear side sill trim cover (one self-tapping screw).

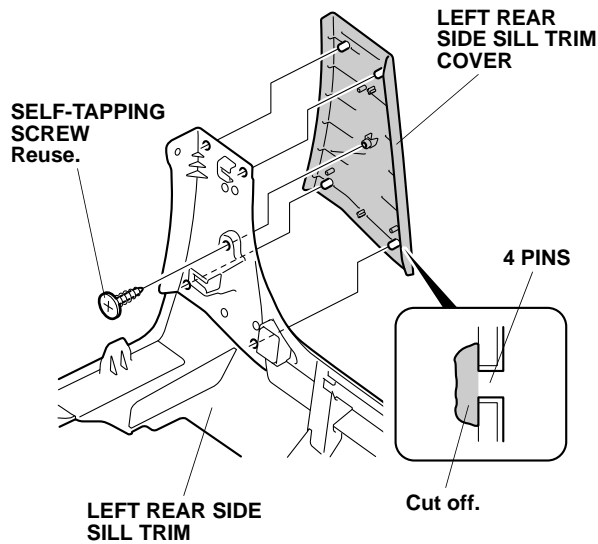

14. Remove the two stops from the left rear side sill trim.

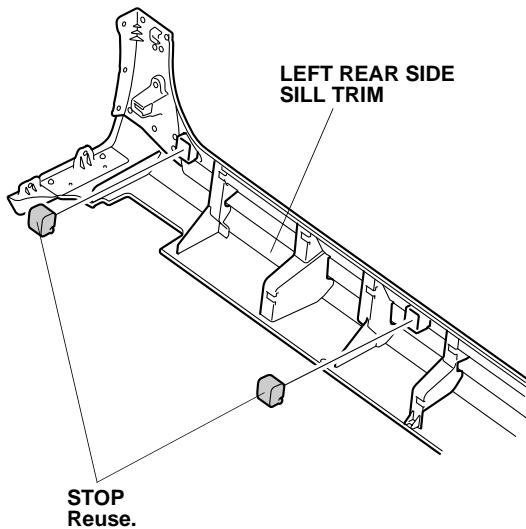

15. Remove the thirteen clips from the vehicle panel. Turn the clips 45° to remove them.

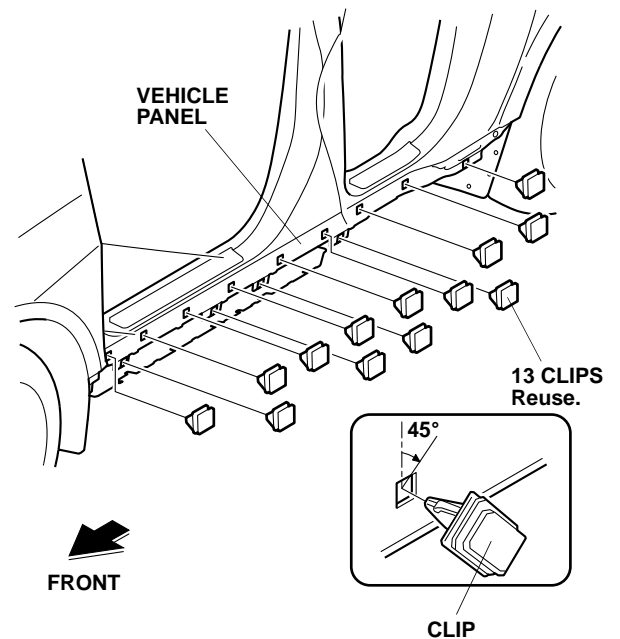

16. Remove the left front side step trim (two retaining tabs and four clips).

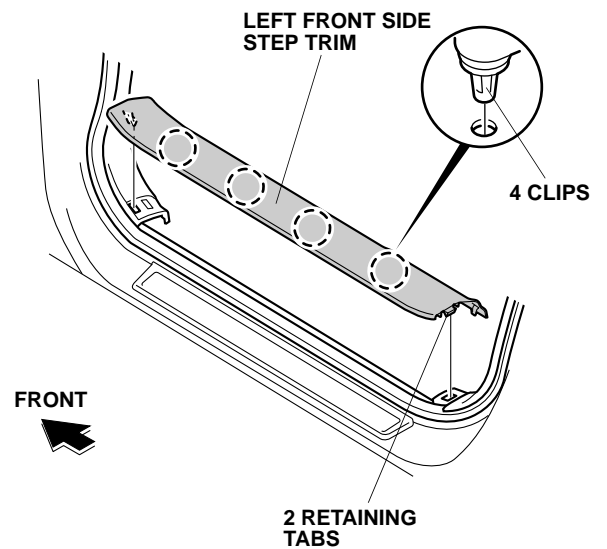

- Pull away the weatherstrip and remove the left kick panel (one cap, three hooks, one clip, and unplug the vehicle connector if equipped).

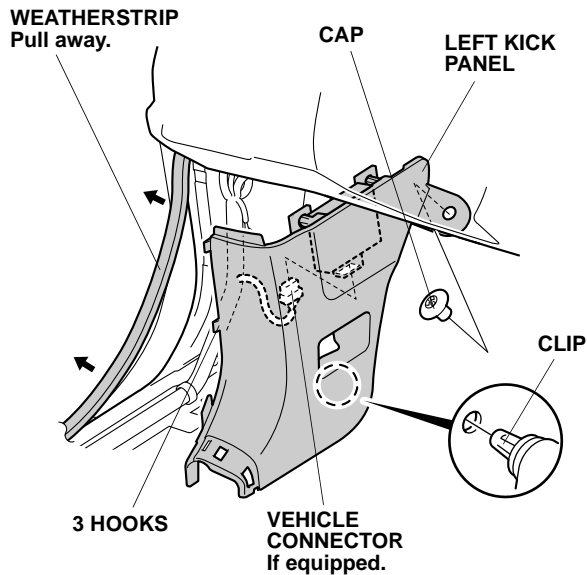

- Install two clip nuts to the vehicle under cover.

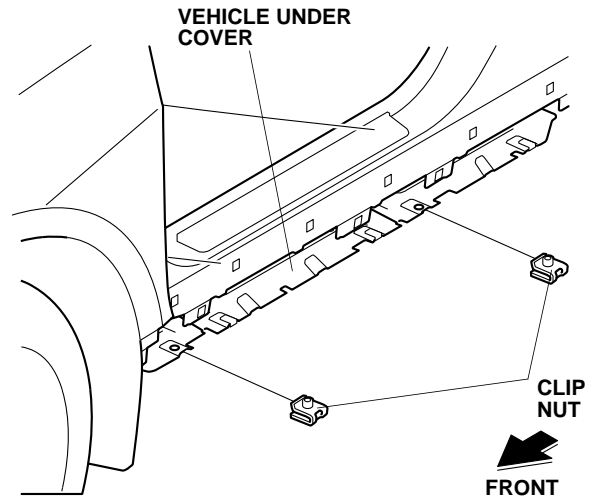

- Install twelve of the thirteen clips (removed in step 15) to the left center trim.

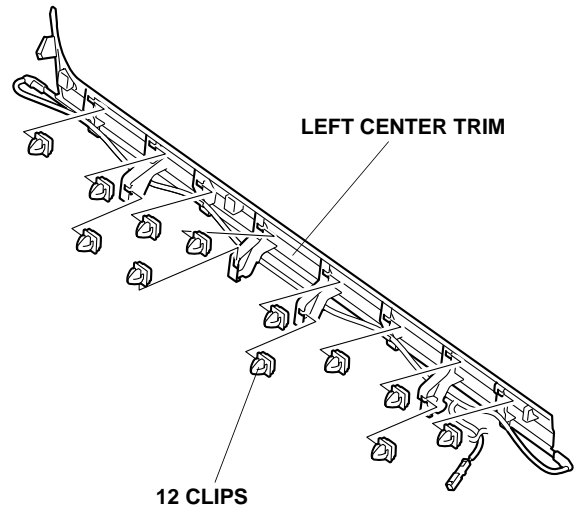

Installing the Center Trim

- Locate the two holes in the vehicle under cover. Use scissors to cut slits in the vehicle under cover in the area shown.

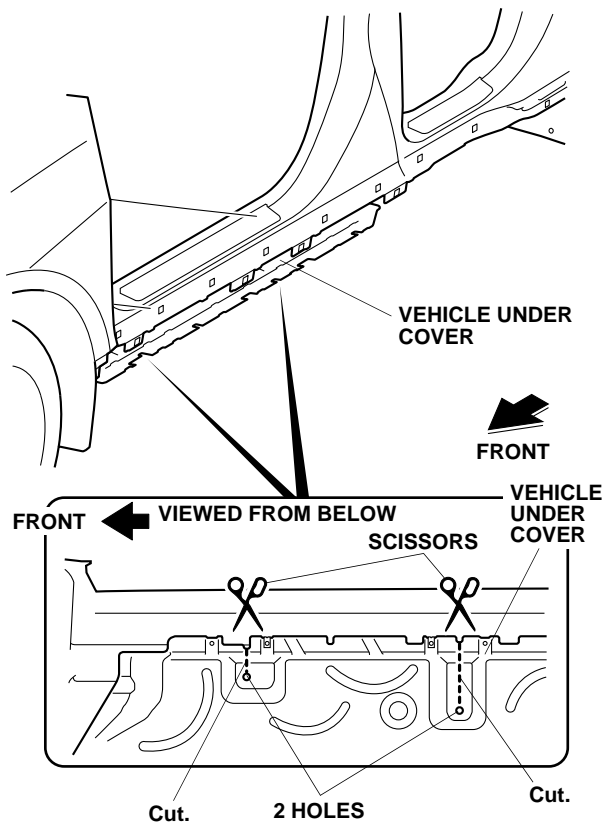

21. Install the two stops (removed in step 14) to the left center trim.

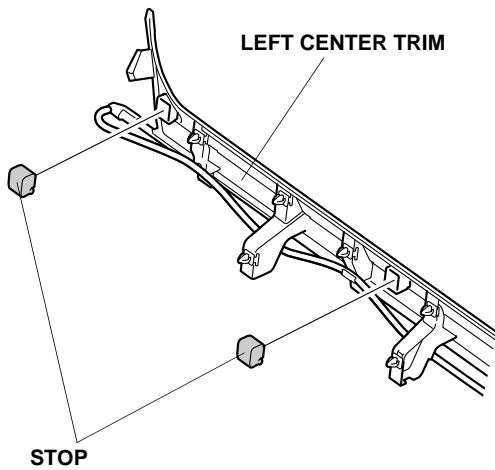

22. Install the left center trim to the vehicle panel with twelve clips.

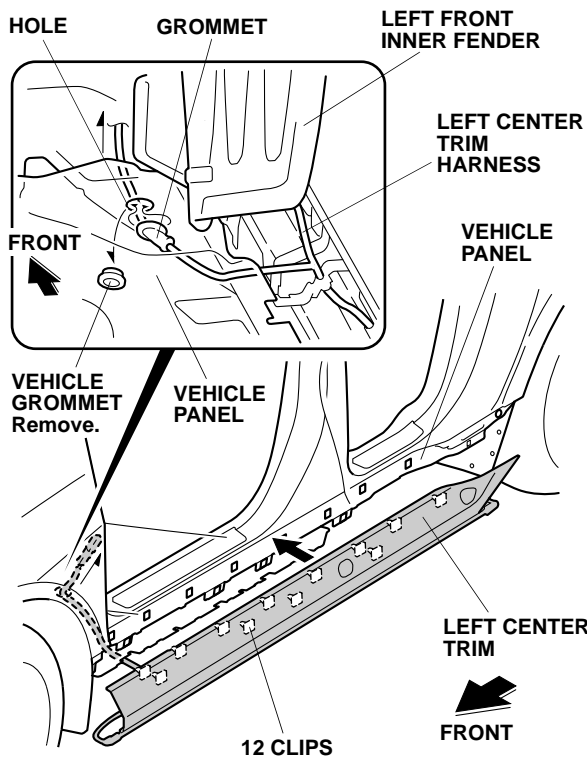

23. Remove the vehicle grommet from the vehicle panel.
24. Route the left center trim harness through the hole in the vehicle panel, and seat the grommet in the hole.

25. In the kick panel area on each side of the vehicle, locate the vehicle 2-pin connector blue-taped to the vehicle harness. Remove the blue tape to free each connector.

NOTE: On the passenger's side, there are two vehicle 2-pin connectors. Locate the one blue-taped to the vehicle harness under the dashboard (it is difficult to see). Check the wire colors (pink and blue) of the 2-pin connector to verify that you have the correct connector.

Driver's Side:

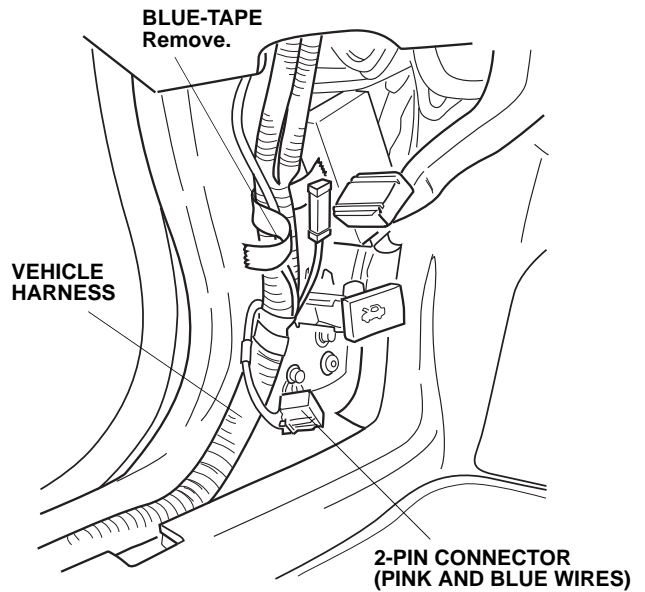

Passenger's Side:

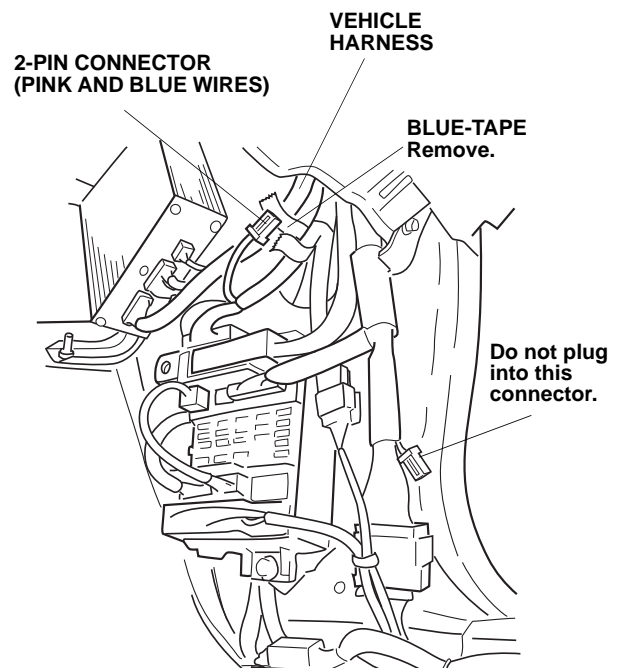

26. Remove one clip and lift the floor carpet. Route the center trim harness forward along the vehicle harness. Remove the dummy connector from the vehicle 2-pin connector (pink and blue wire) you located in step 25, and plug the center trim harness 2-pin connector to the vehicle 2-pin connector.

Driver's Side:

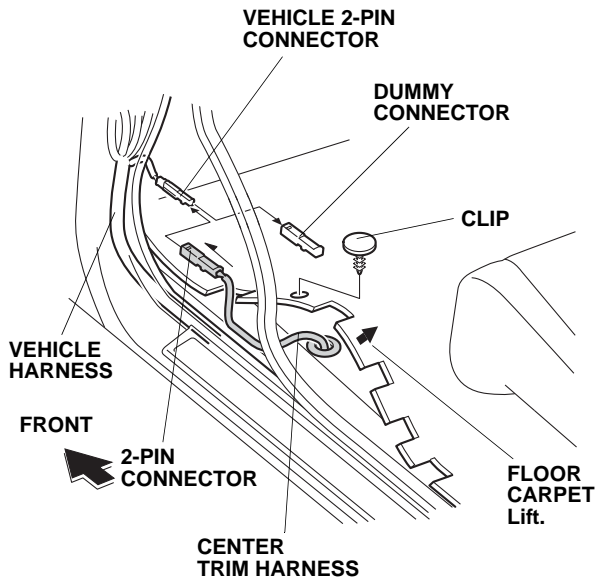

Passenger's Side:

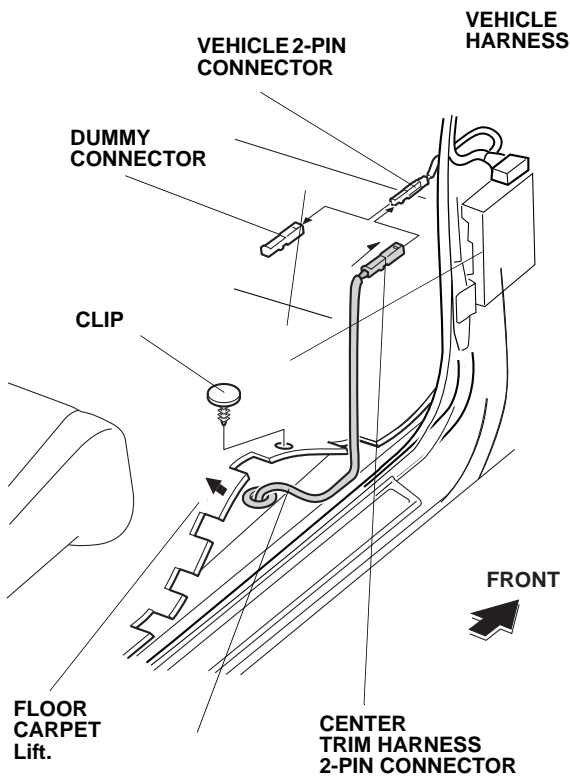

27. Secure the 2-pin connector and left center trim harness to the vehicle harness with two wire ties.

Driver's Side:

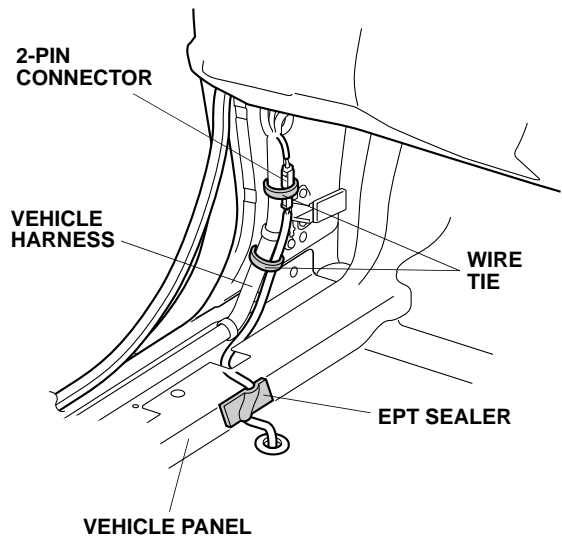

Passenger's Side:

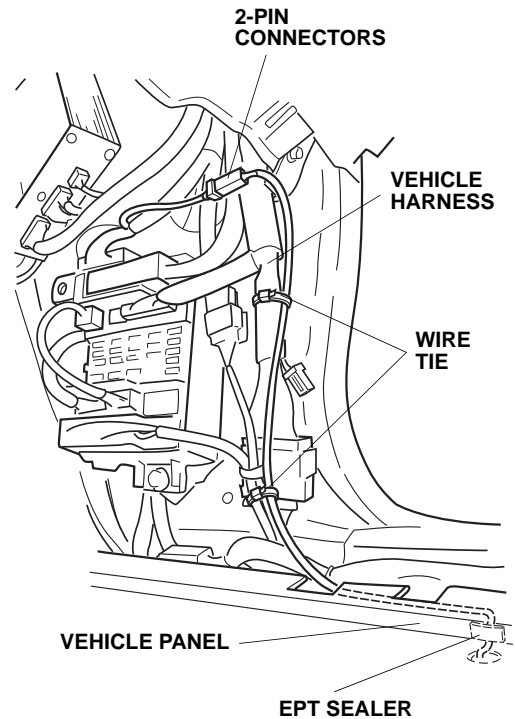

28. Using isopropyl alcohol on a shop towel, thoroughly clean the area where the EPT sealer will attach.
29. Secure the center trim harness to the vehicle panel with one EPT sealer as shown.

Installing the Sport Running Board

30. Install four spring nuts to four brackets on the left center trim.

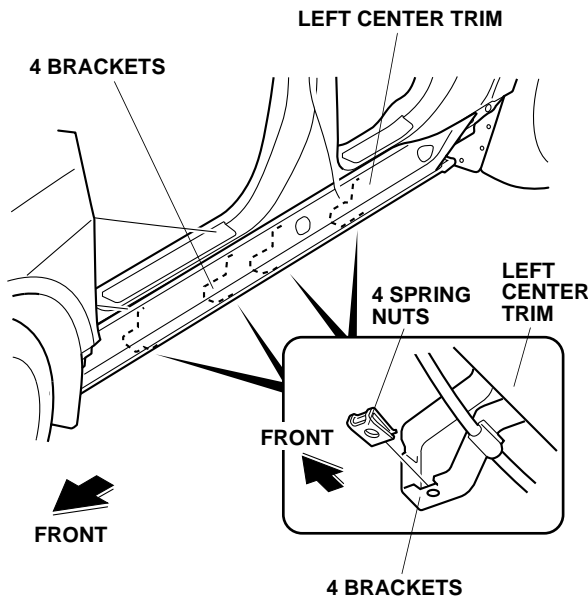

31. Loosely secure the left bracket A to the vehicle frame with two 8 x 20 mm flange bolts. The bracket is marked "left." Make sure to install the flange bolts in the correct position and orientation.

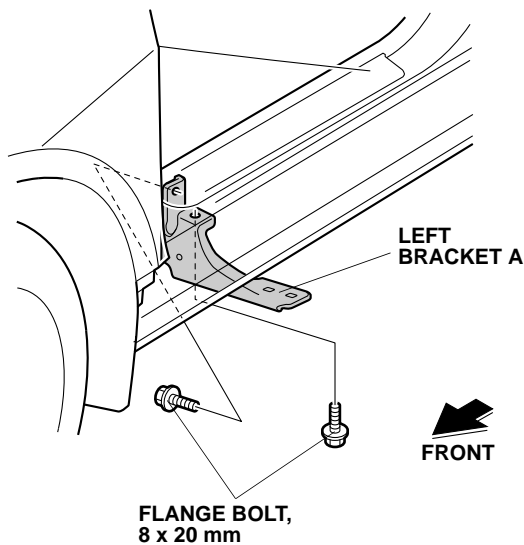

32. Loosely secure two left brackets B to the vehicle frame with four 8 x 20 mm flange bolts. The brackets are marked "left." Make sure to install the flange bolts in the correct position and orientation.

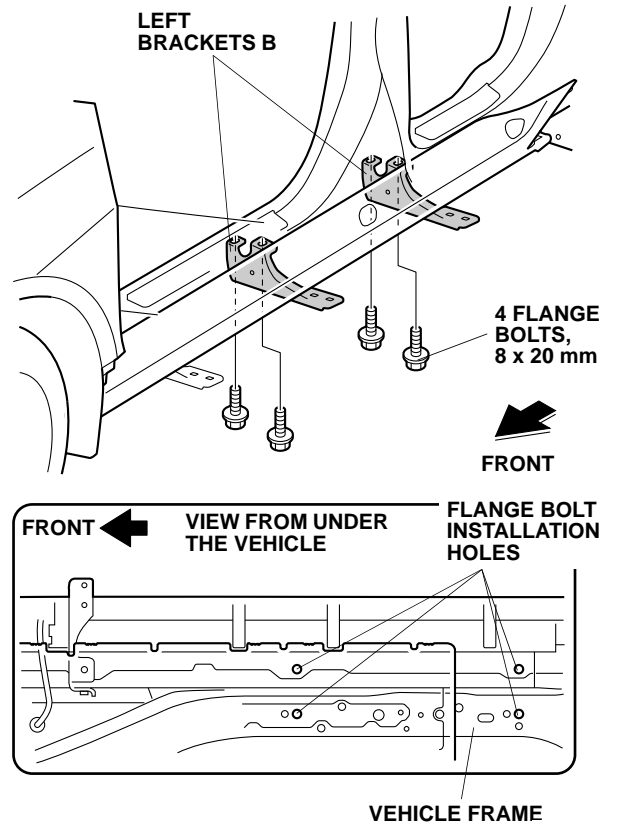

33. Install the left front side sill trim cover (removed in step 9) to the left front end cap with one self-tapping screw and three push nuts. Use an 8 mm socket to install the push nuts. Make sure to install the push nuts in the correct direction.

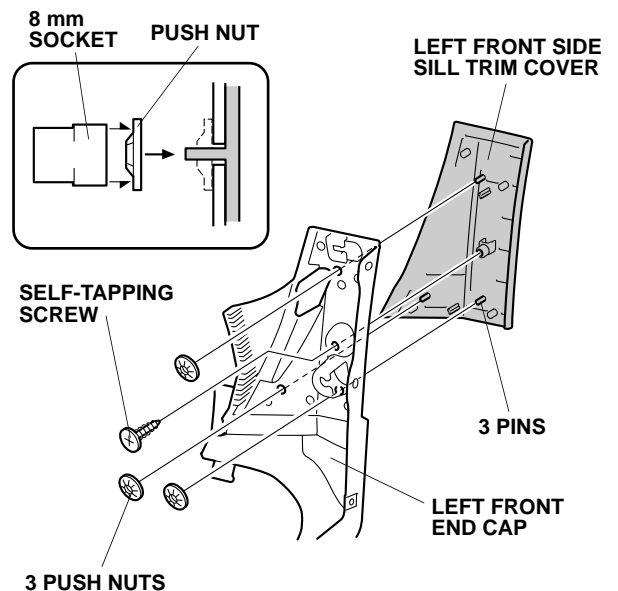

34. Install the two clips (removed in step 7) to the left front end cap.

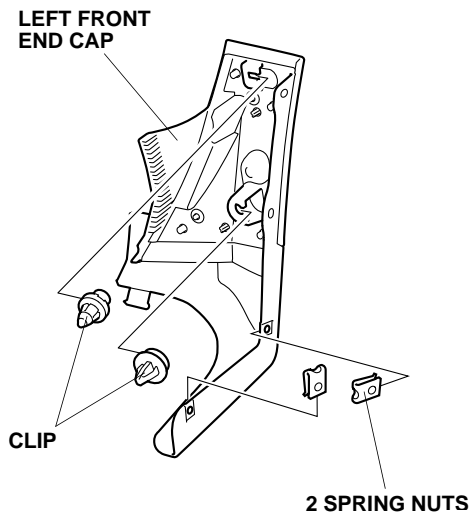

35. Install the two spring nuts (removed in step 8) to the left front end cap.
36. Install the left rear side sill trim cover (removed in step 13) to the left rear end cap with one self-tapping screw and three push nuts. Use an 8 mm socket to install three push nuts. Make sure to install the push nuts in the correct direction.

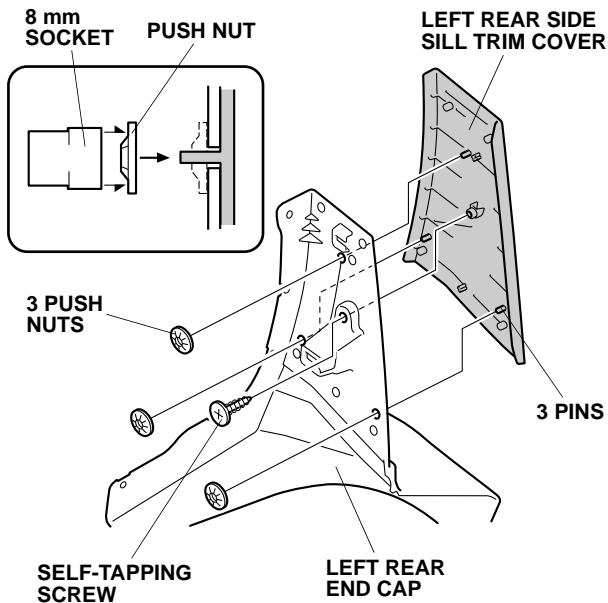

37. Install two clips (removed in step 10 and 15) to the left rear end cap.

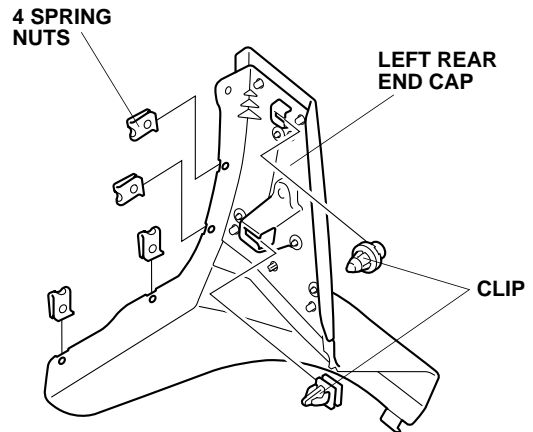

38. Install four spring nuts (removed in step 4) to the left rear end cap.
39. Insert three square head bolts into each channel of the sport running board.

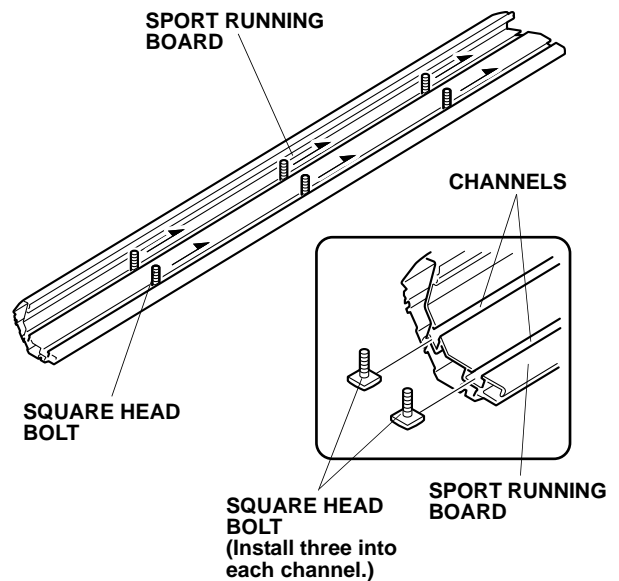

40. Insert one bullet tab on the left front end cap into the sport running board, and rotate the left front end cap as shown.

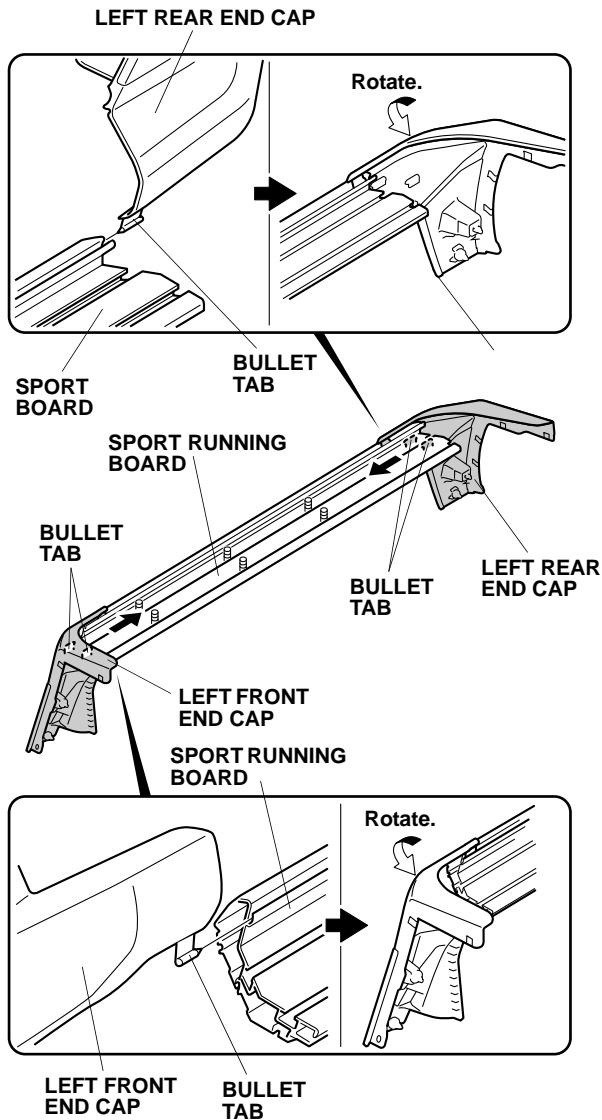

41. Secure the left front end cap to the sport running board with two bullet tabs.
42. Insert one bullet tab on the left rear end cap into the sport running board, and rotate the left rear end cap as shown.
43. Secure the left rear end cap to the sport running board with two bullet tabs.

44. Install the sport running board to the left bracket A and the two left brackets B by inserting the six square head bolts into the holes in the brackets. Install one flange nut to each square head bolt, and torque the flange nuts to 27 N·m (20 lbf·ft).

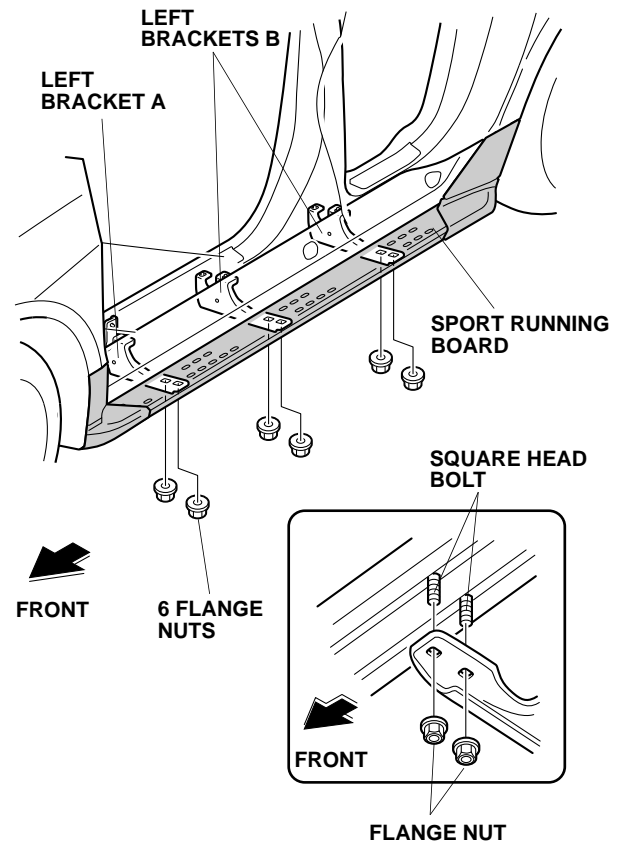

45. Torque the flange bolts (installed in step 31 and 32) to 27 N·m (20 lbf·ft).
46. Secure the front of the sport running board to the vehicle with the two clips installed in step 34, and four self-tapping screws removed in step 7.

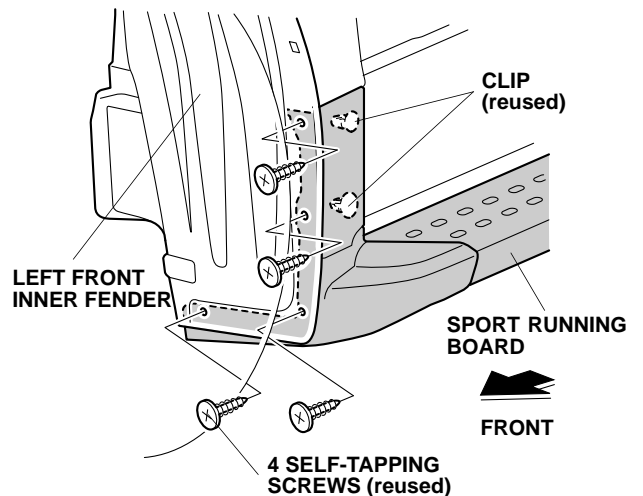

- Secure the rear of sport running board to the vehicle with the two clips installed in step 37, and the five self-tapping screws removed in step 3.

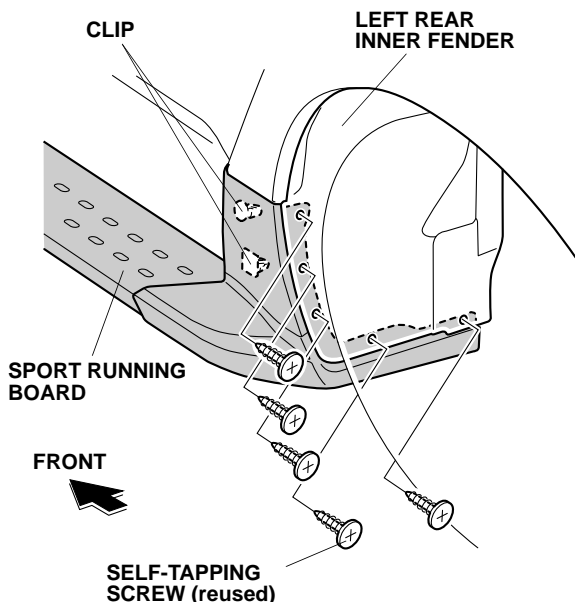

- Install the left under cover to the sport running board.

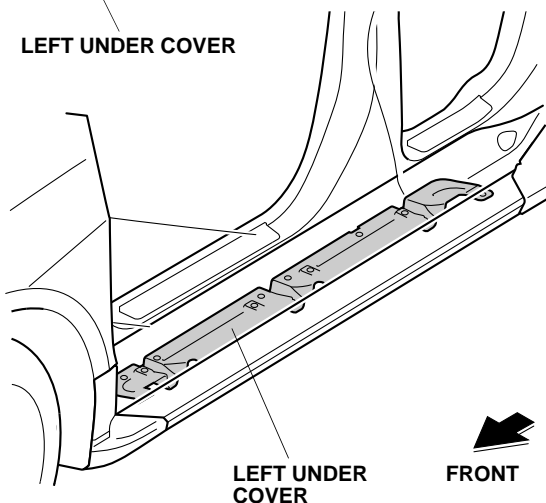
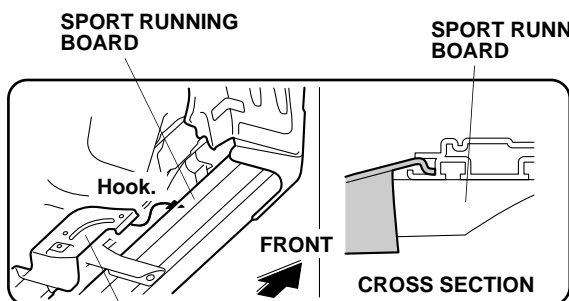

- Insert one square head bolt into the rear channel of the sport running board.

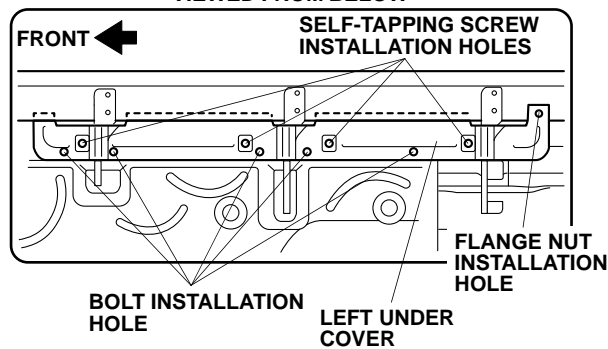
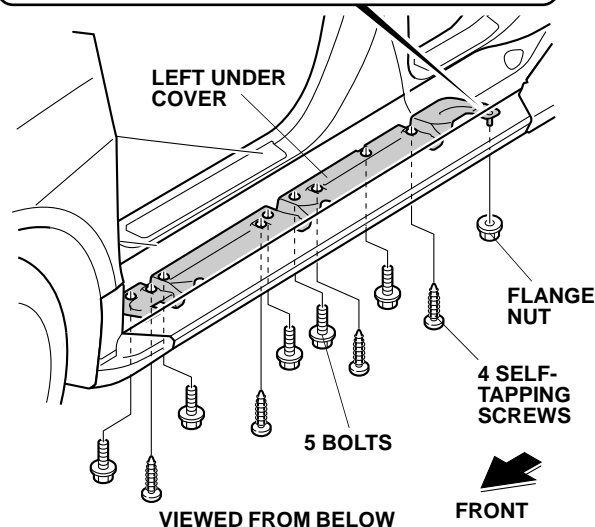
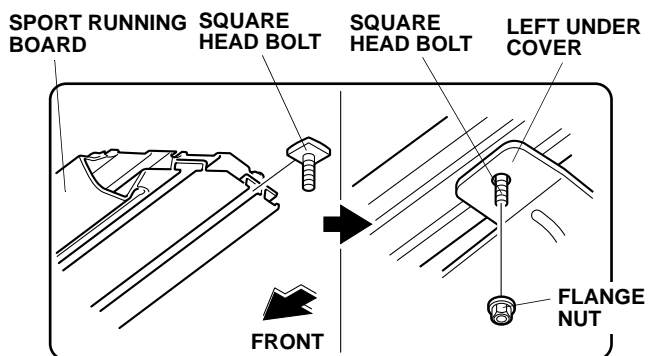

- Secure the left under cover to the vehicle with four self-tapping screws, five bolts, and one flange nut.
- Repeat steps 3 through 50 to install the right sport running board to the passenger's side of the vehicle.
- Check that all wire harnesses are routed properly and all connectors are plugged in.
- Reinstall all removed parts.
- Reconnect the negative cable to the battery.
- Enter the anti-theft code for the audio and navigation system if equipped, and reset the radio station presets.
- Reset the clock.