



INSTALLATION INSTRUCTIONS

Accessory
REMOTE CONTROL ENGINE STARTER

Application
2011 RDX

Publications No.
BII 43535
Issue Date
JULY 2010

PARTS LIST

**Remote Engine Starter Unit Kit
P/N 08E91-E22-200B**

Transmitter

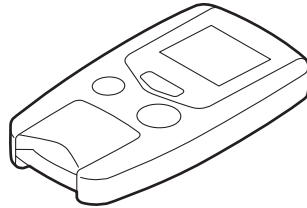

Control unit

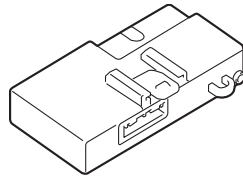

Antenna

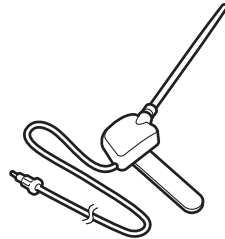

Key ring



Protective tape



Fuse label

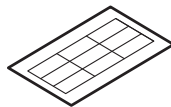

Caution label

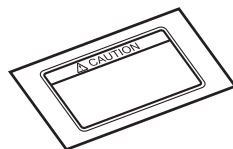

Accessory User's Information Manual

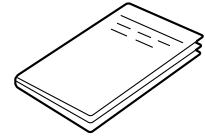

Quick Start Guide

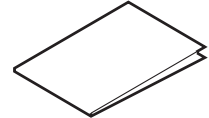

**Remote Control Engine Starter Attachment Kit
P/N 08E92-STK-200B**

Engine starter harness

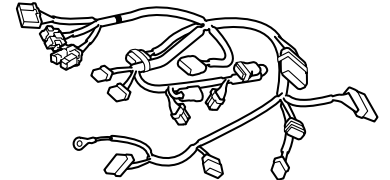

Control unit bracket

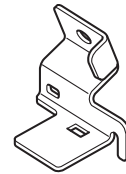

Template

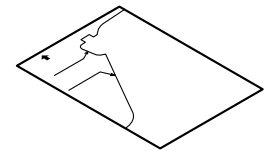

2 Relays

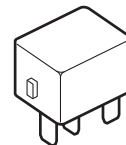

18 Wire ties

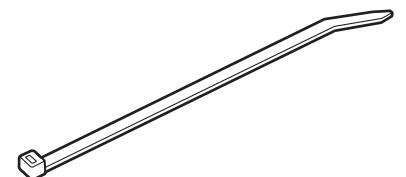

Pillar clip

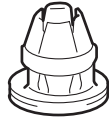

8 Urethane tapes

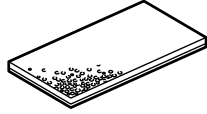

Ground bolt

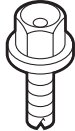

Harness clip

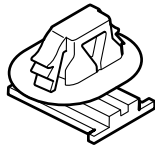

TOOLS AND SUPPLIES REQUIRED

Phillips screwdriver
Flat-tip screwdriver
Small flat-tip screwdriver
4 mm Hex wrench
Ratchet
8 mm and 10 mm Sockets
12 mm Socket (Deep)
Combination wrench
Plastic trim tool
T/N SILTRIMTL 10
Isopropyl alcohol
Shop towel
Tape measure
Needle nose pliers
Felt-tip pen
Diagonal cutters
Scissors
Rubber mallet
HDS (Honda Diagnostic System)
Masking tape
10 mm Wrench

Illustration of the Engine Starter Installed on the Vehicle

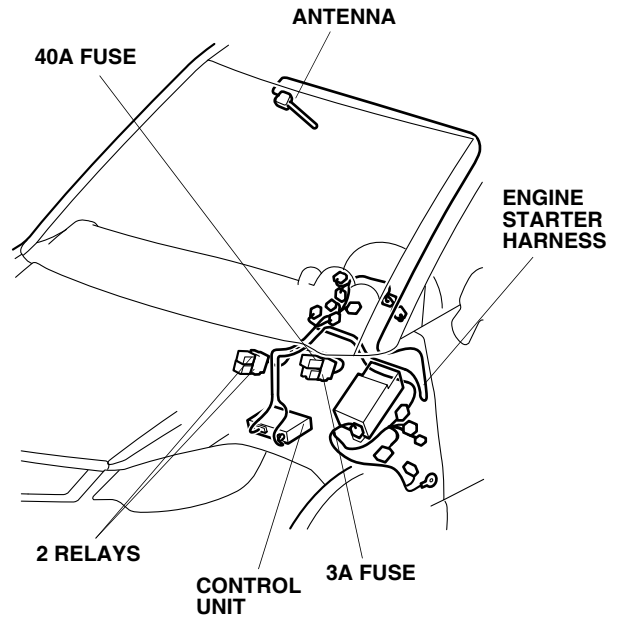

INSTALLATION

Client Information: The information in this installation instruction is intended for use only by skilled technicians who have the proper tools, equipment, and training to correctly and safely add equipment to your vehicle. These procedures should not be attempted by “do-it-yourselfers.”

NOTE: This antenna should be installed only if the ambient air temperature is 15°C (60°F) or above.

1. Make sure you have the anti-theft code for the audio unit and the navigation system (if equipped), then write down the radio presets.
2. Disconnect the negative cable from the battery.

Setting the Control Unit

3. Touch the metal part of the screwdriver to any metal part of the vehicle to discharge any static electricity.

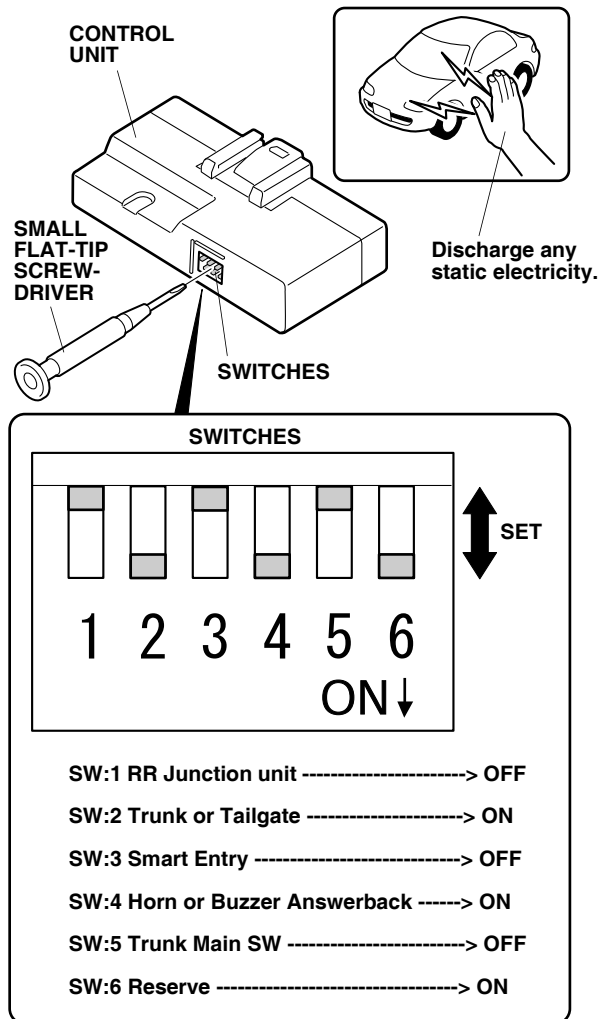

4. Check the position of the switches on the control unit.

NOTE:

- The switches must be selected before the control unit is plugged in.
 - If the switch settings are not correct, the remote engine starter will not operate correctly.
 - If you change the switch settings with the unit connected, you must disconnect the unit, then reconnect it before the new settings are recognized.
5. Using a small flat-tip screwdriver, set the switches on the control unit as shown.

6. Using isopropyl alcohol on a shop towel, clean the area where the protective tape will attach. Remove the adhesive backing from the protective tape, and attach the protective tape to the control unit over the switches.

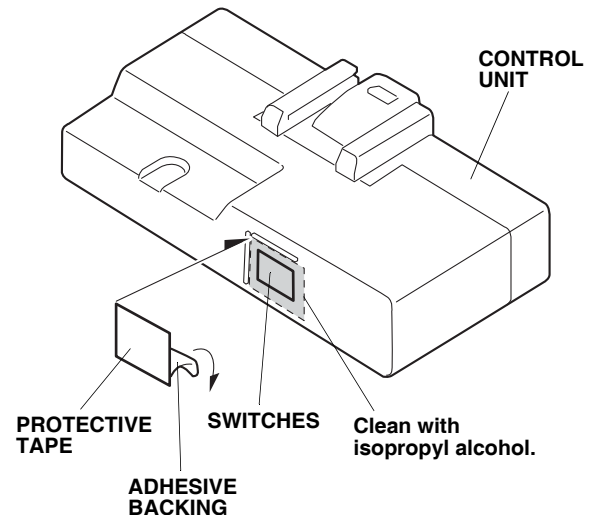

- Using a plastic trim tool, remove the map light (two retaining tabs and one clip, and unplug the vehicle connectors).

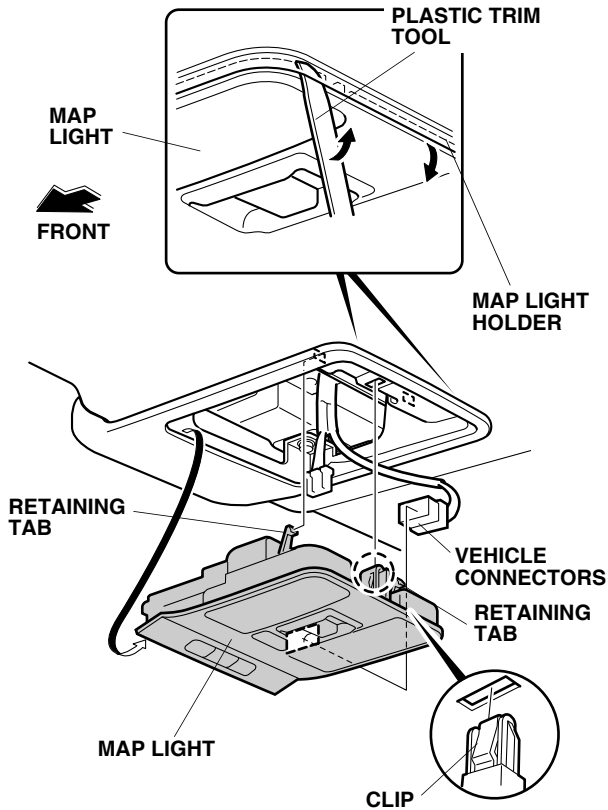

- Remove the map light holder (four bolts).

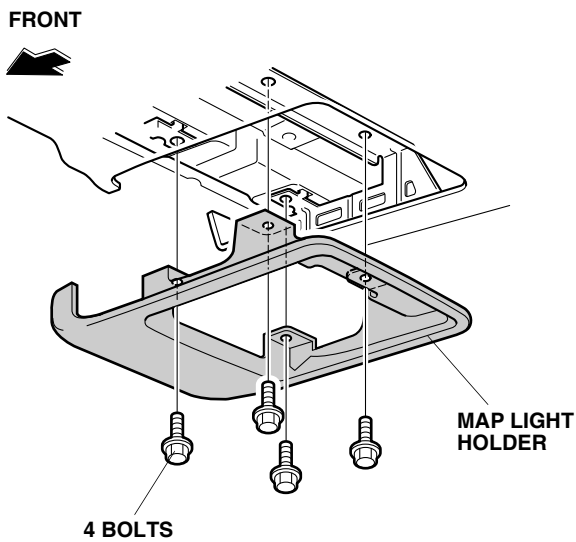

- Using a flat-tip screwdriver, remove the right and left sunvisor holders.

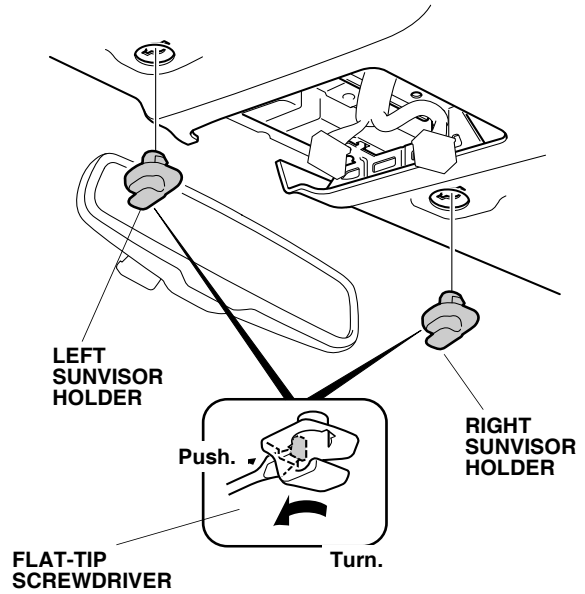

- Pull away the weatherstrip from the left A-pillar trim.

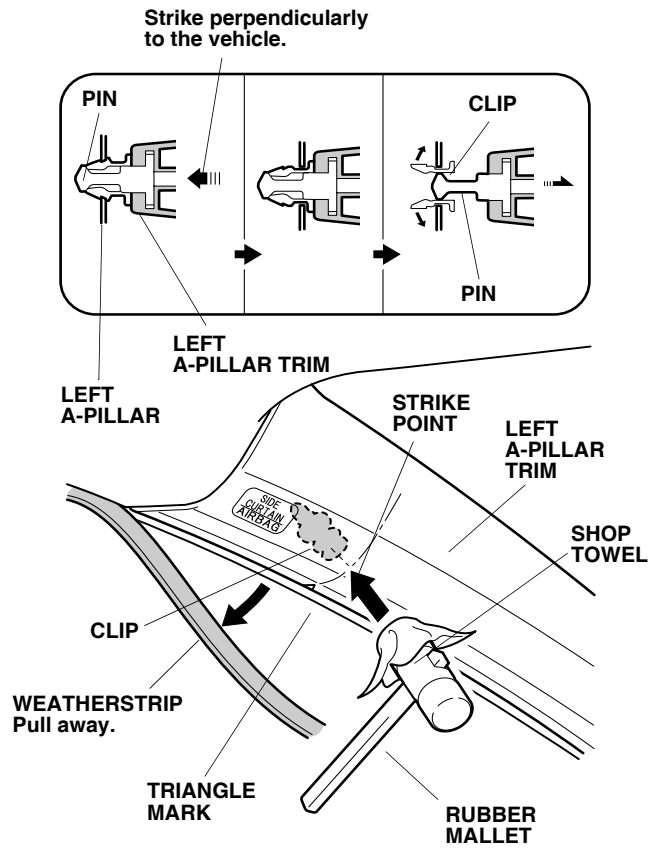

- Using a rubber mallet and a shop towel, gently strike the area shown on the left A-pillar trim to release the clip.

12. Remove the left A-pillar trim (two clips).

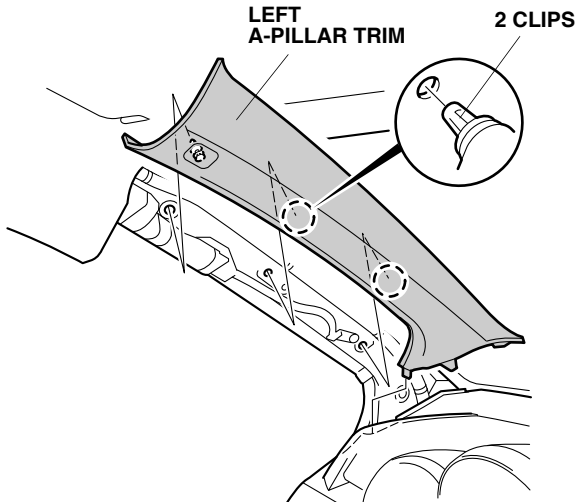

13. Remove and discard the pillar clip from the left A-pillar, and install a new pillar clip (supplied) on the left A-pillar trim.

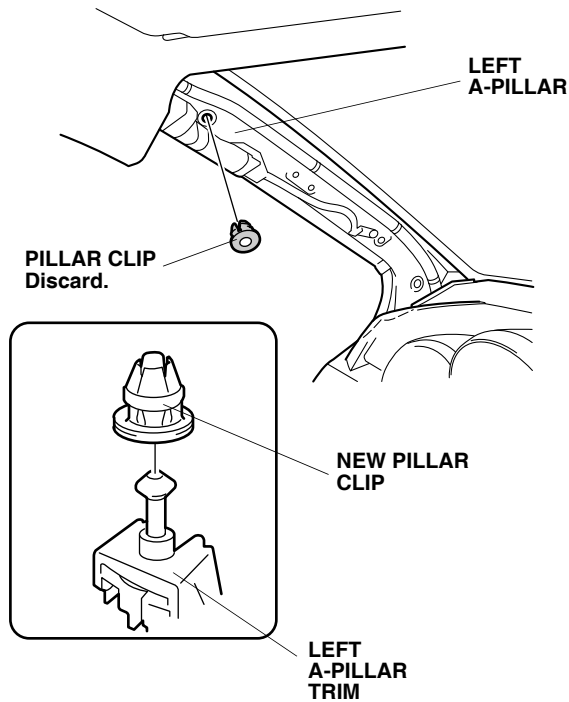

14. Remove the left front side step trim (five clips and two tabs).

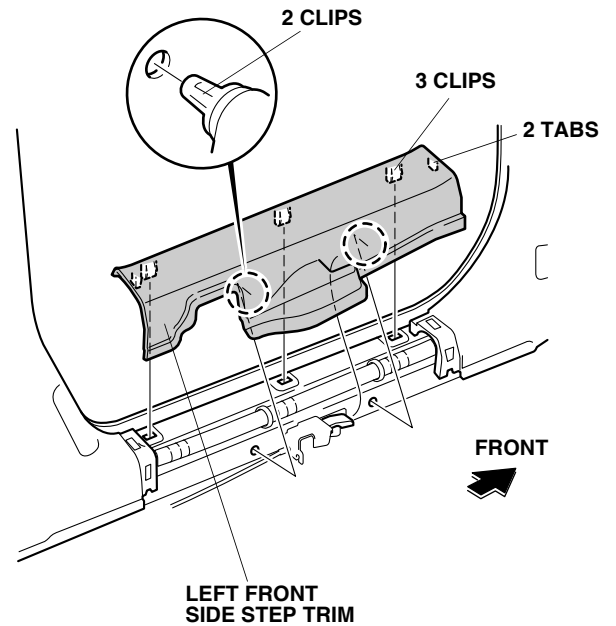

15. Pull away the weatherstrip and remove the driver's kick panel (two clips).

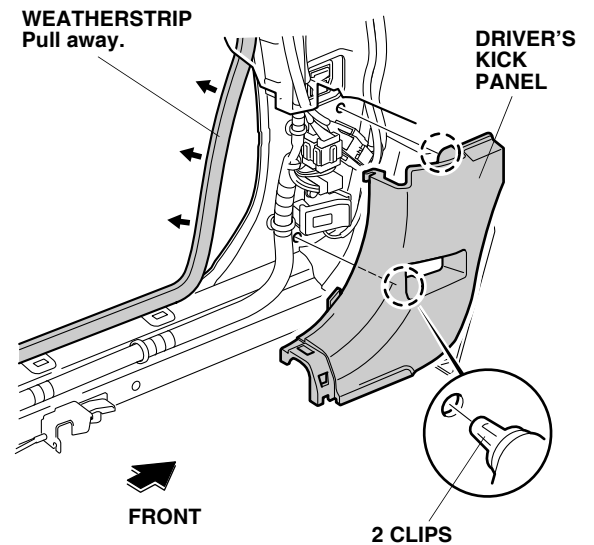

16. Remove the instrument side panel (two clips, two retaining tabs, and unplug the vehicle connectors).

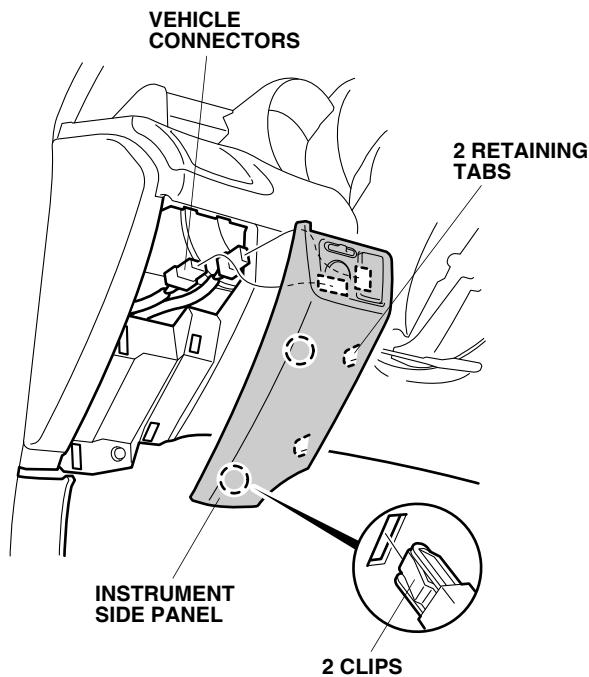

17. Release the driver's under cover (turn the knob counterclockwise, and disconnect two clips).

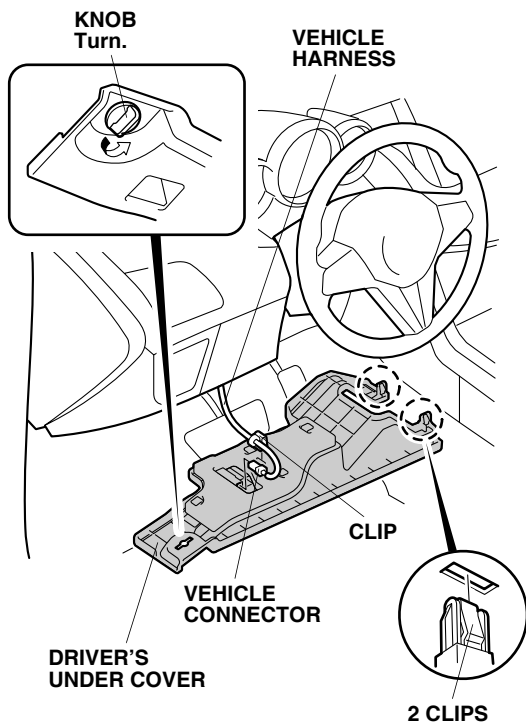

18. Release the vehicle harness (one clip) and remove the driver's under cover (unplug the vehicle connector).

19. Remove the upper and lower steering column covers:

- Lower the tilt lever and pull the steering wheel out.
- Remove the two lower self-tapping screws and the lower screw.
- Turn the steering wheel as necessary to access each self-tapping screw, and remove the two self-tapping screws.
- Using a Phillips screwdriver, push in on the two tabs to release the upper steering column cover from the lower steering column cover.
- Release the hooks, and remove the covers.

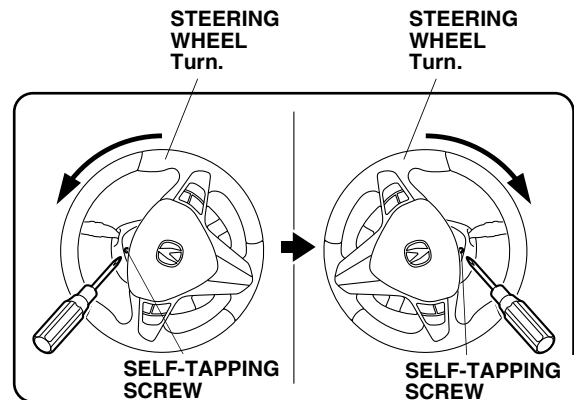

Push in on the tabs through the screw holes to release the steering column upper cover lock tabs.

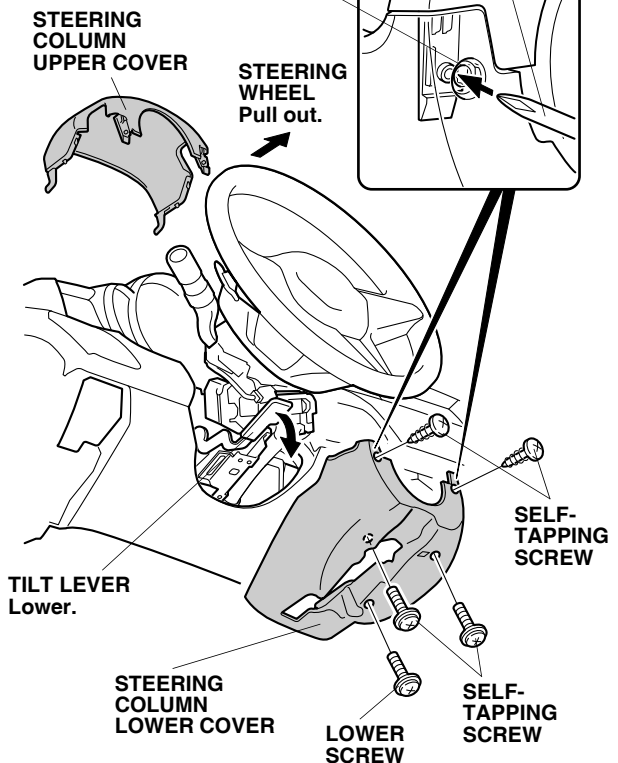

Routing the Engine Starter Harness

20. Remove the bracket from the steering column lower cover (two retaining tabs).

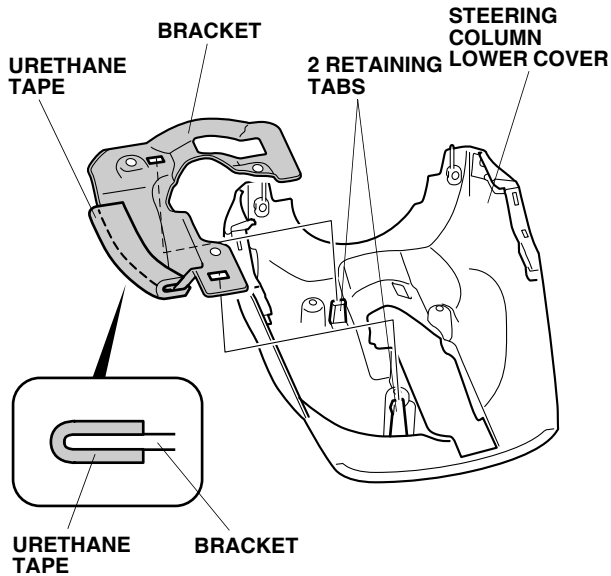

21. Using isopropyl alcohol on a shop towel, clean the bracket surface where the urethane tape will attach. Attach one urethane tape as shown.
22. Reinstall the bracket to the steering column lower cover.
23. Install the two relays to the engine starter harness relay block.

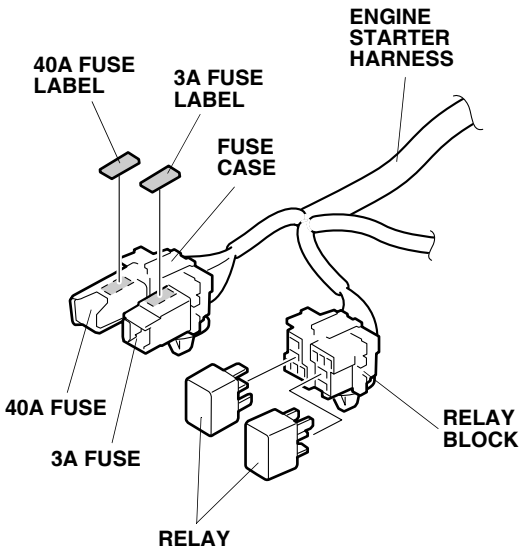

24. Attach the 3A fuse label and the 40A fuse label to the engine starter harness fuse case.

25. Unplug the vehicle 7-pin connector (green) and the vehicle 6-pin connector (green).

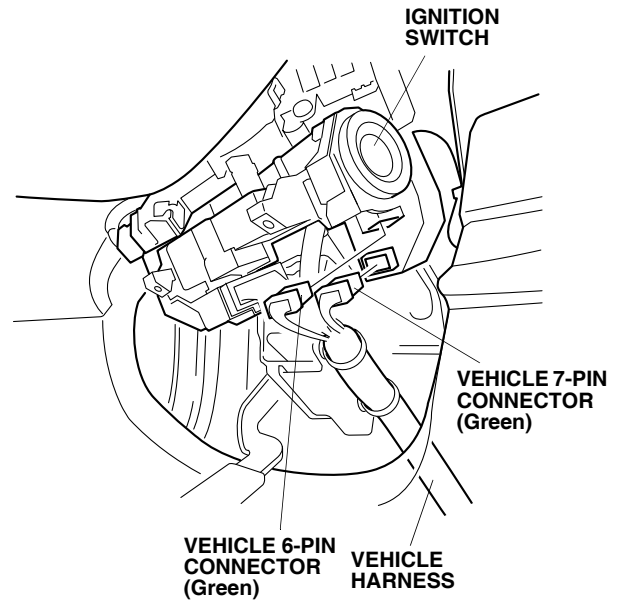

26. Unplug the vehicle 7-pin connector (brown).

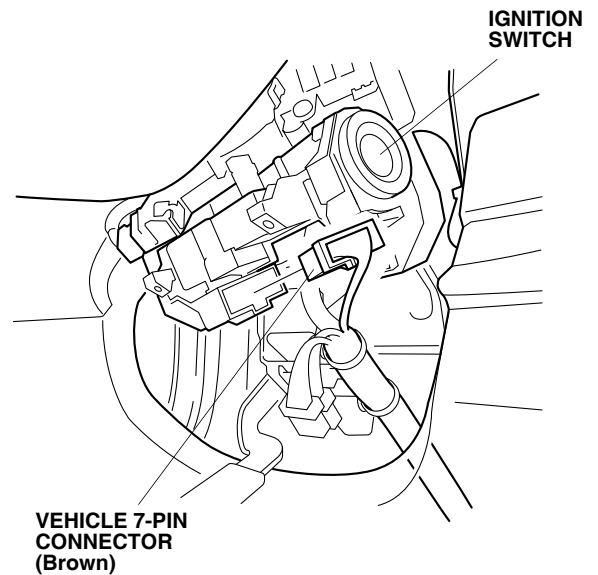

27. Route the engine starter harness to the ignition switch.

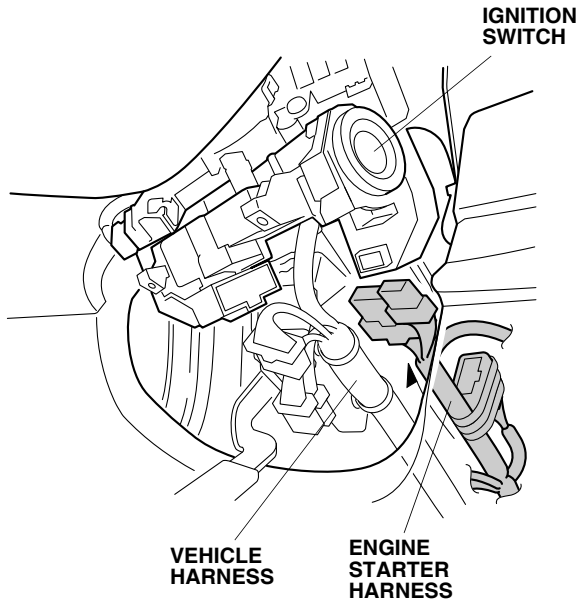

28. Plug the vehicle 7-pin connector (brown) into the engine starter harness 7-pin connector (brown) and route the engine starter harness as shown.

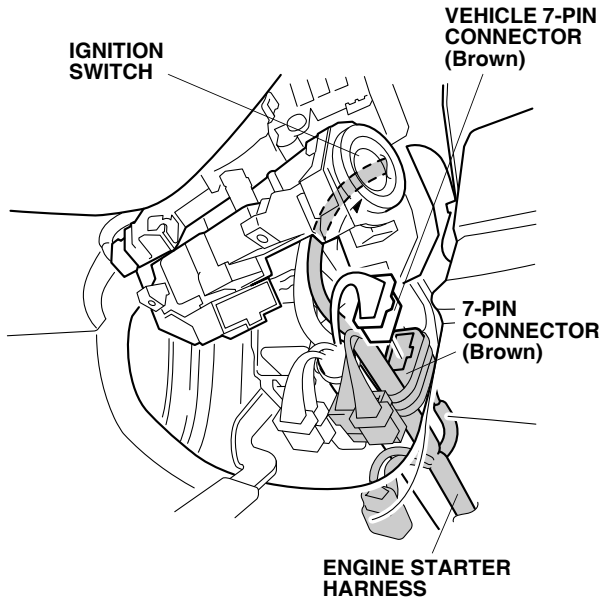

29. Plug the engine starter harness 7-pin connector (green) into the vehicle 7-pin connector.

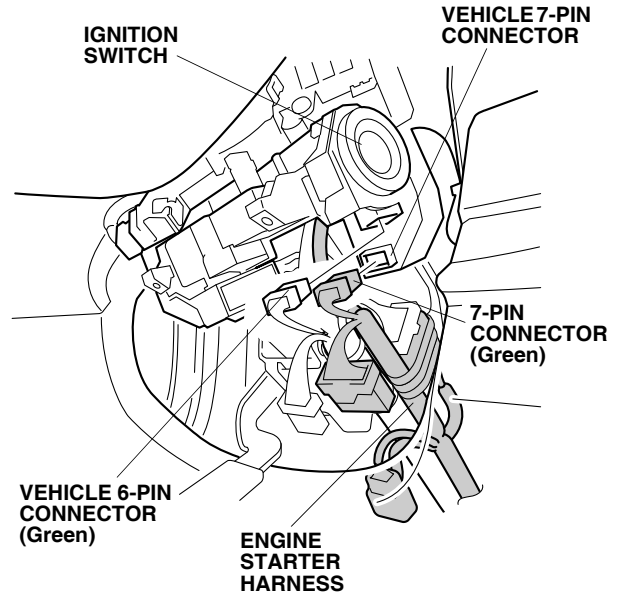

30. Reconnect the vehicle 6-pin connector (green) unplugged step in 25.
31. Plug the vehicle 7-pin connector (green) into the engine starter harness 7-pin connector (green).

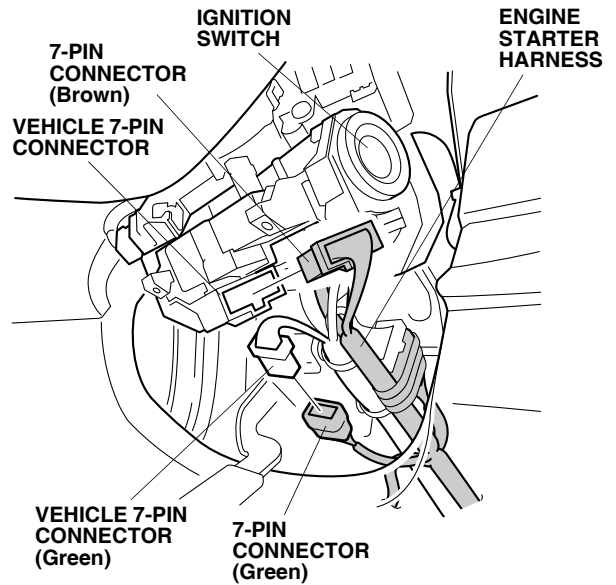

32. Plug the engine starter harness 7-pin connector (brown) into the vehicle 7-pin connector.

NOTICE

Check that the engine starter harness 7-pin connector (brown) is securely plugged into the vehicle connector. If the connector is loose, the engine can stall.

33. Route the engine starter harness as shown.

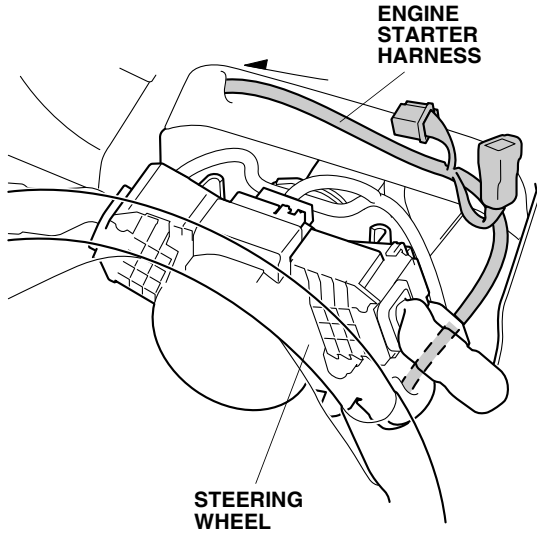

34. Unplug the vehicle 12-pin headlight switch connector. Plug the engine starter harness 12-pin connector into the headlight switch connector. Plug the vehicle 12-pin headlight switch connector you just unplugged into the engine starter harness 12-pin connector.

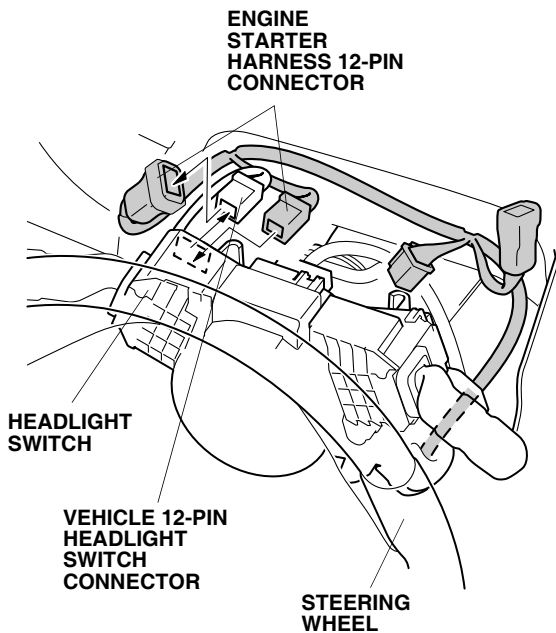

35. Unplug the vehicle 8-pin wiper switch connector, and plug in the engine starter harness 8-pin connector into the wiper switch. Plug the vehicle 8-pin wiper switch connector you just unplugged into the engine starter harness 8-pin connector.

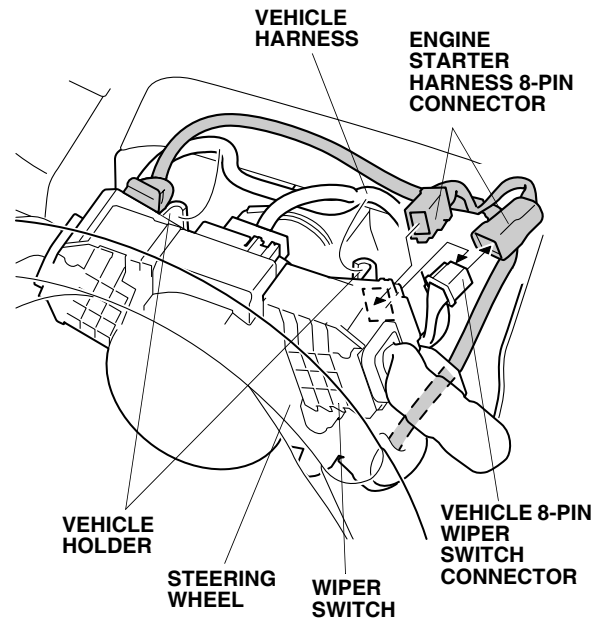

36. Secure the engine starter harness 12-pin connector to the engine starter harness with one wire tie as shown.

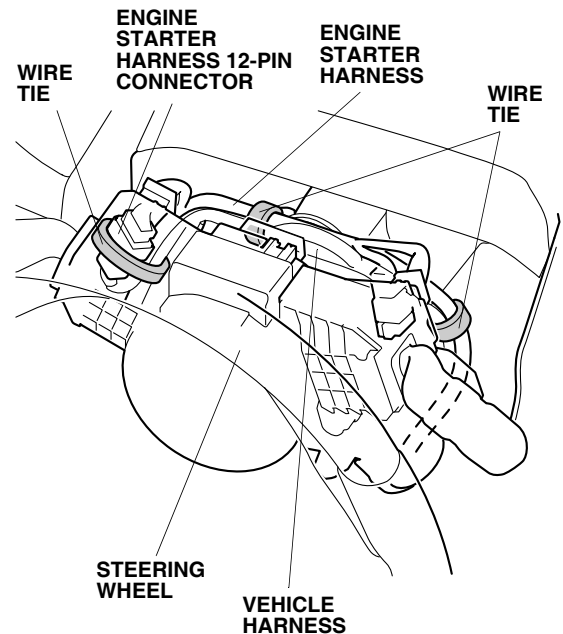

37. Secure the engine starter harness to the vehicle harness with two wire ties.

38. Secure the engine starter harness to the vehicle harness with two wire ties.

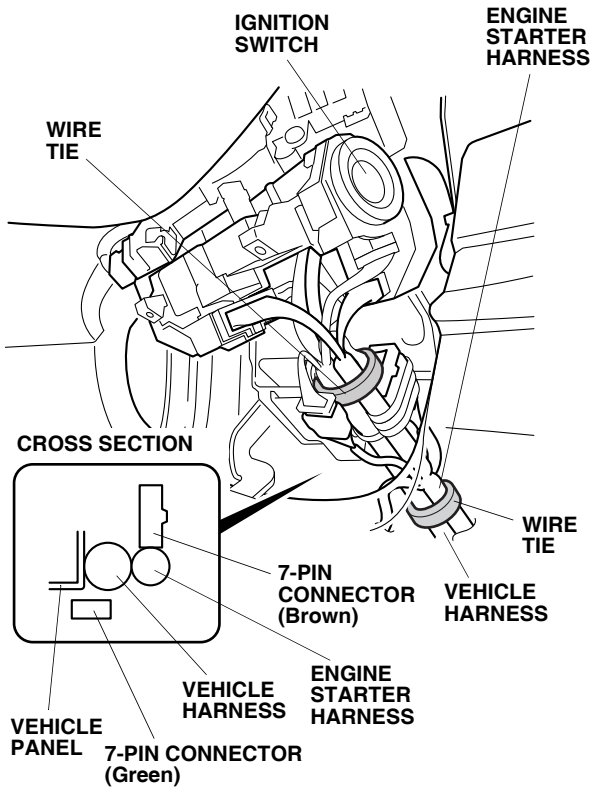

39. Attach the engine starter harness relay block and engine starter harness fuse case to the vehicle bracket.

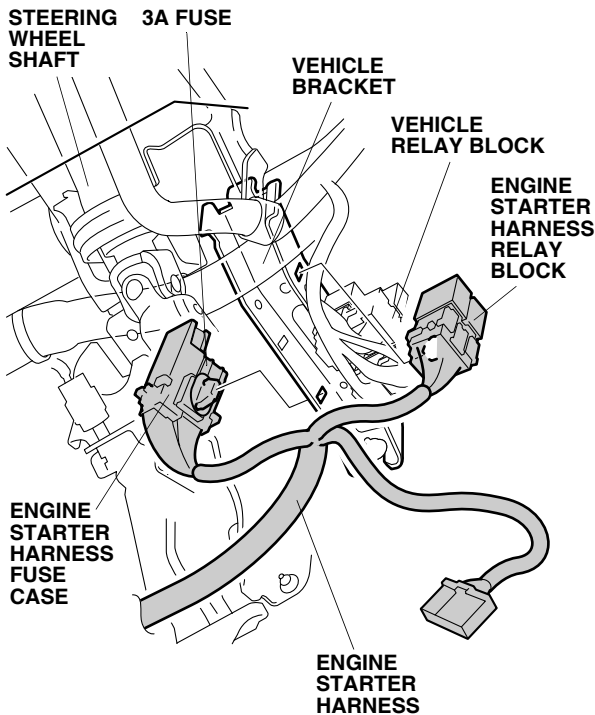

40. Route the engine starter harness as shown.

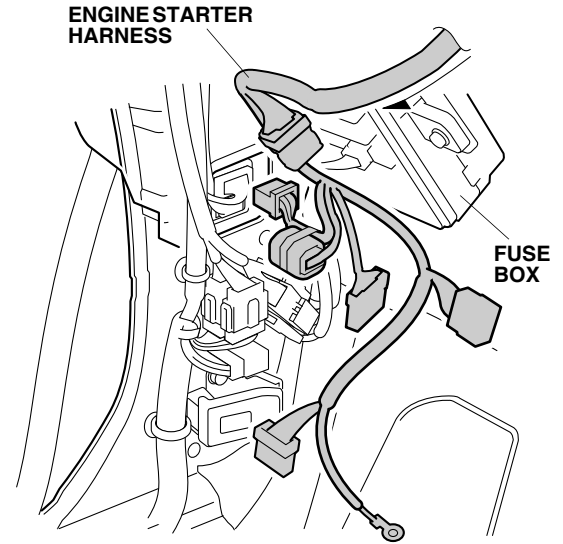

41. Unplug the vehicle 18-pin connector (white) located inside the vehicle frame, and plug the engine starter harness 18-pin connector into the vehicle 18-pin connector. Plug the vehicle 18-pin connector you just unplugged into the engine starter harness 18-pin connector.

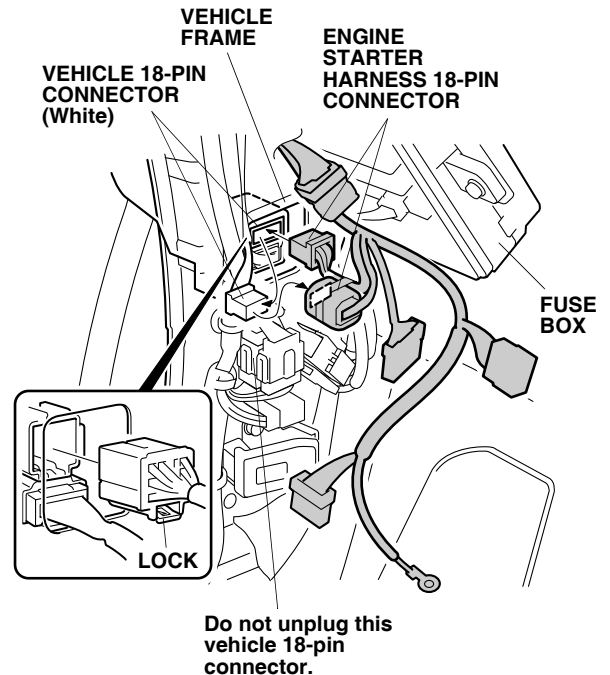

42. Unplug the vehicle 20-pin connector (white). Plug the engine starter harness 20-pin connector (white) into the vehicle 20-pin connector (white) you just unplugged into the engine starter harness 20-pin connector (white).

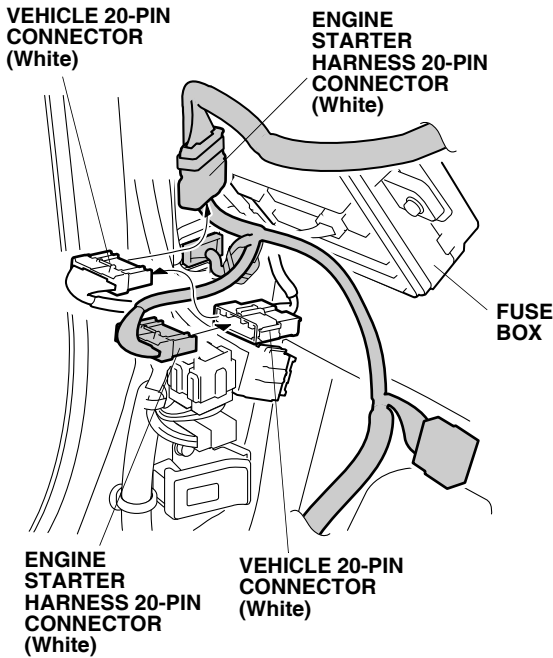

43. Remove the green and yellow connectors that are attached together from the vehicle body. Replace the clip.

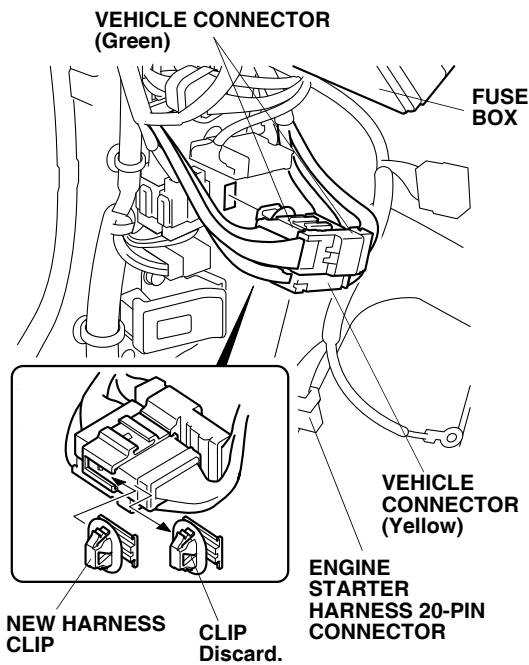

44. Route the engine starter harness 20-pin connector to the position under the fuse box.

45. Unplug the vehicle 20-pin connector (green). Plug the engine starter harness 20-pin connector into the vehicle 20-pin connector (green). Plug the vehicle 20-pin connector (green) you just unplugged into the engine starter harness 20-pin connector.

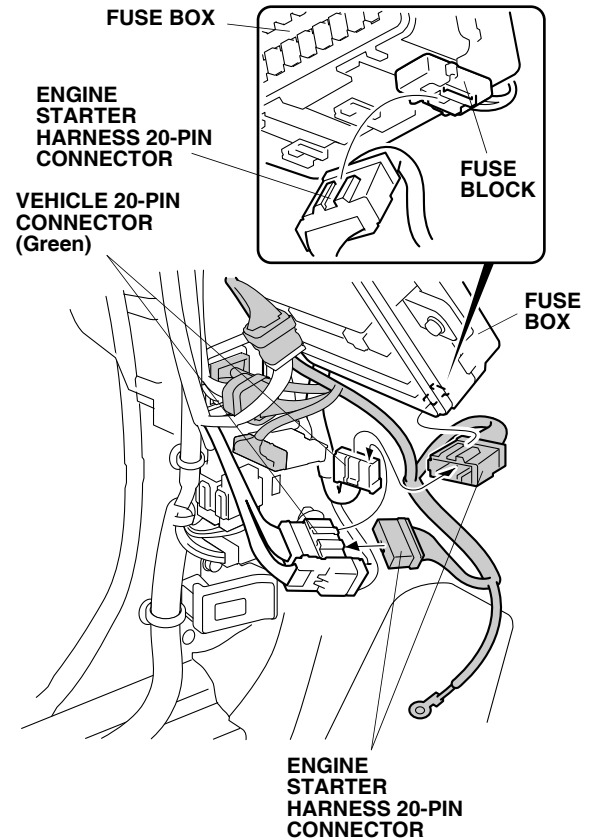

46. Install the engine starter harness 20-pin connector to the fuse block as shown.
47. Reinstall the two green and yellow connectors removed in step 43.

48. Remove and discard the lower hood opener bolt.

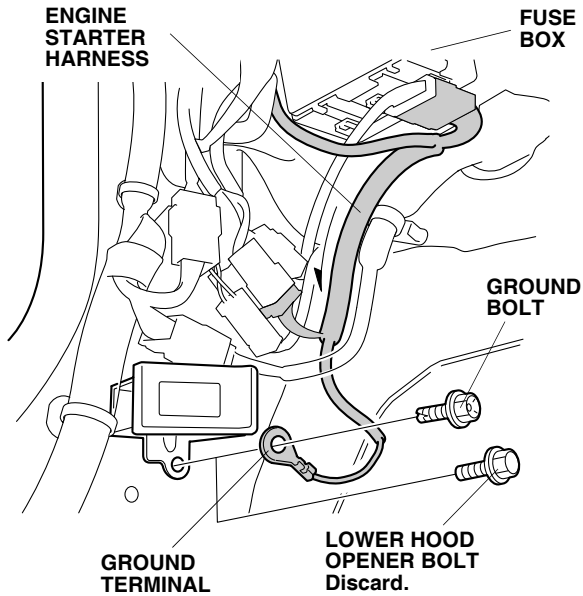

49. Secure the engine starter harness ground terminal to the lower hood opener, and install the ground bolt.
50. Secure the engine starter harness to the vehicle harness using three wire ties. Do not secure the engine starter harness to any yellow SRS harness.

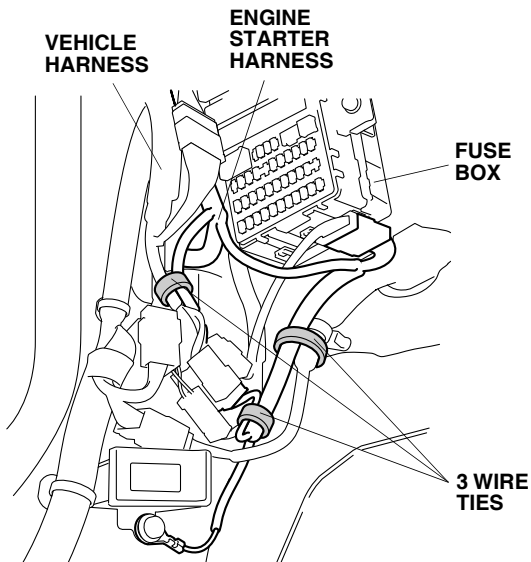

Installing the Antenna

51. Cut out the template.

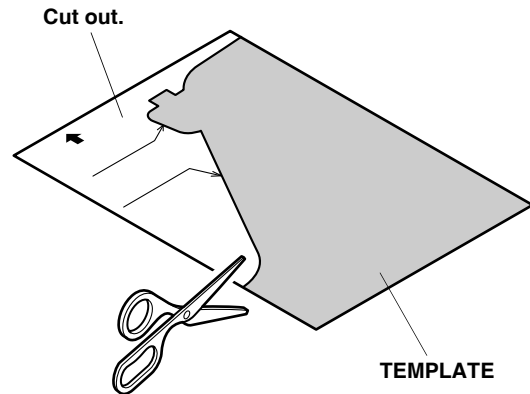

52. Using isopropyl alcohol on a shop towel, clean the windshield surface where the template will attach. Position the template on the black painted surface of the front windshield by aligning its edges with the contour of the black painted area. Secure the template to the windshield using masking tape.

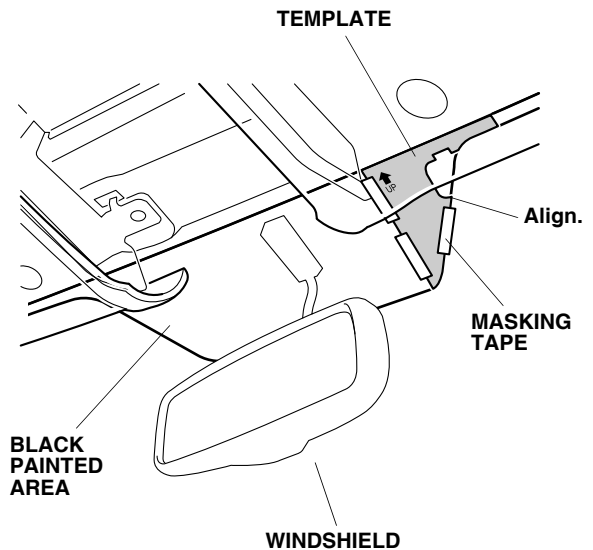

53. Starting near the antenna end of the cable, wrap two urethane tapes around the antenna cable at the measurements shown.

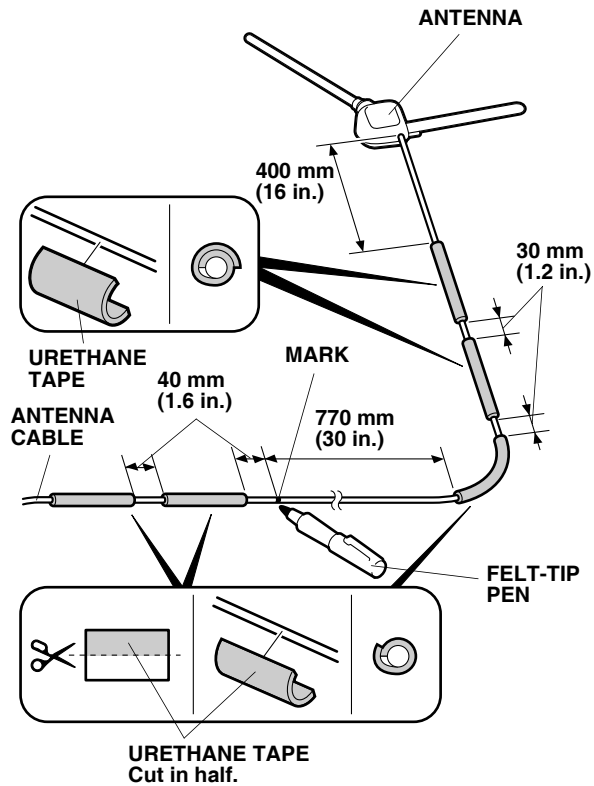

54. Using scissors, cut two urethane tapes in half. Wrap three halves of the urethane tape around the antenna cable at the measurements shown.
55. Using a felt-tip pen, make a mark on the antenna cable at the measurement shown.

56. Measure and mark the antenna plate. Using two pairs of needle nose pliers, bend the antenna plate to the angle shown.

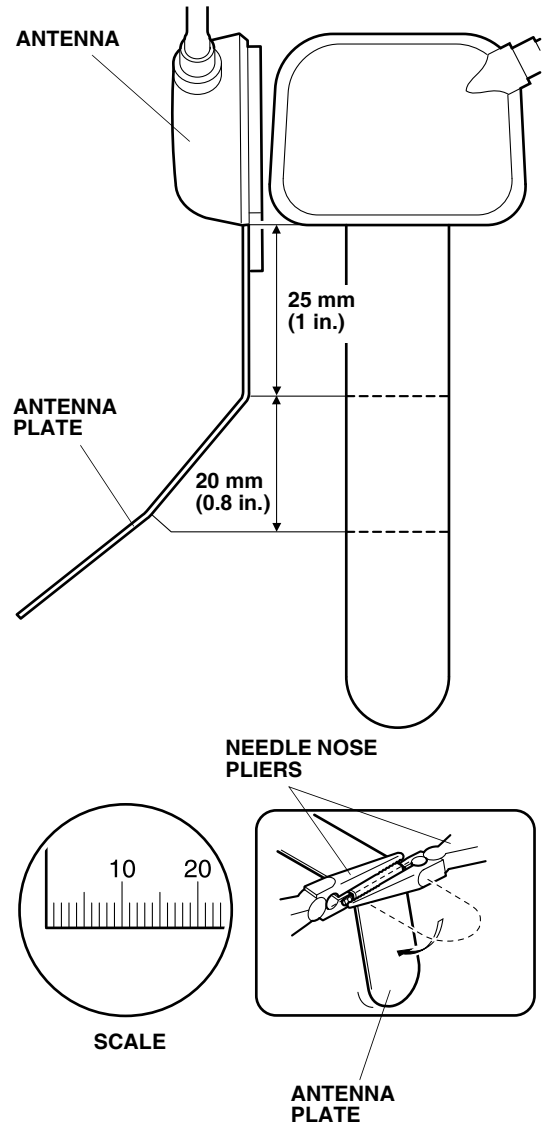

57. Attach one piece of urethane tape (cut in step 54) to the antenna plate as shown. Trim to fit.

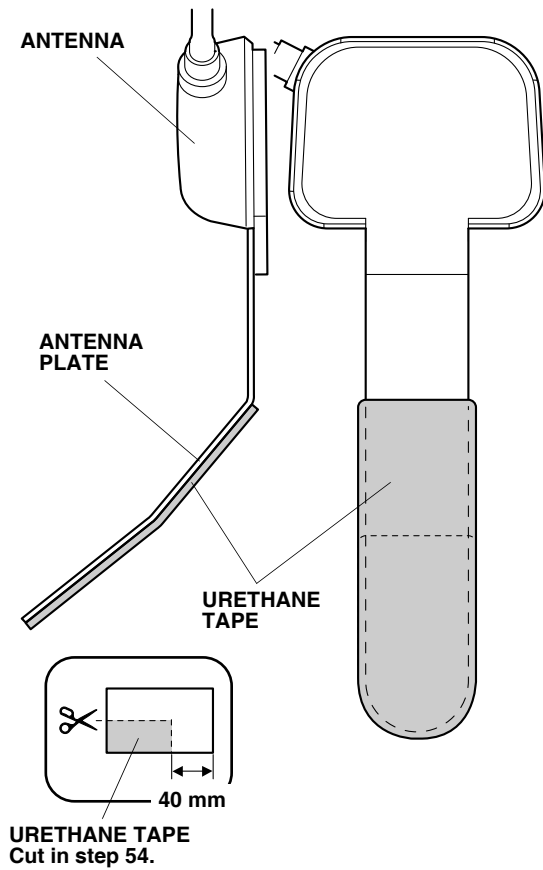

58. Using isopropyl alcohol on a shop towel, clean the windshield where the antenna will attach.

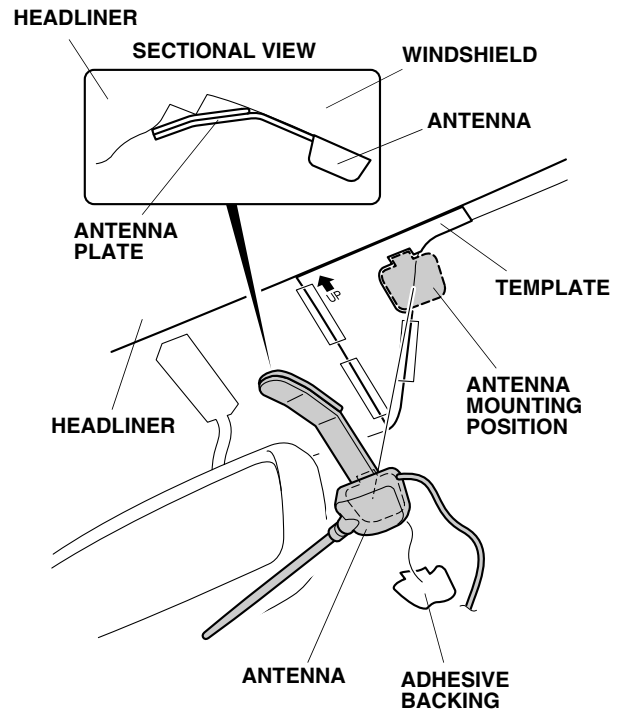

59. Remove the adhesive backing from the antenna. Insert the antenna plate under the headliner, and then attach the antenna to the windshield at the location shown.
60. Remove the template.

61. Using isopropyl alcohol on a shop towel, clean the roof panel where the urethane tape will attach.

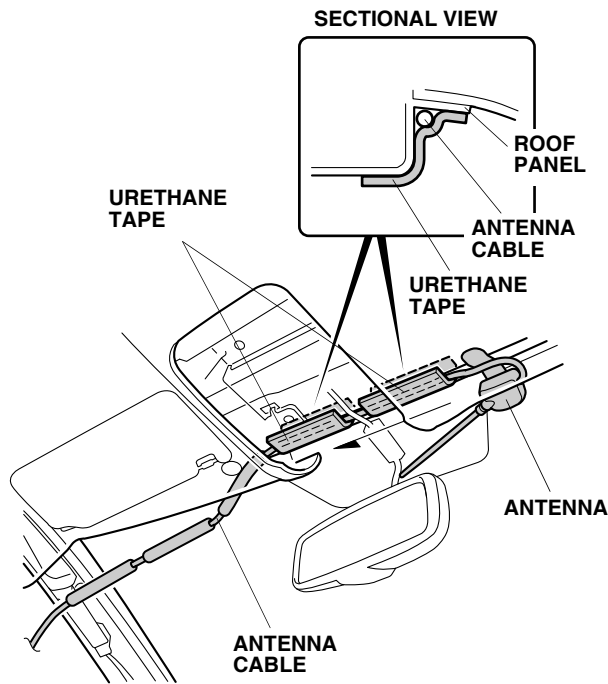

62. Route the antenna cable towards the driver's side of the vehicle, and secure the antenna cable to the roof panel with two urethane tapes.
63. Gently pull down the headliner, and tuck the antenna cable under the headliner. Be careful not to crease the headliner.

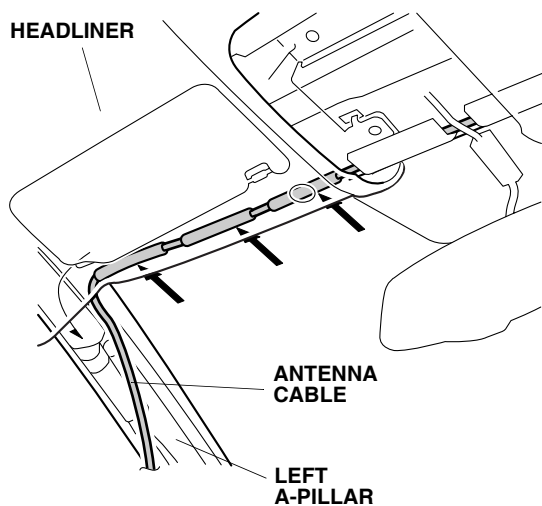

64. At the left A-pillar, route the antenna cable down along the vehicle harness. Align the mark you made on the antenna cable with the lower vehicle clip, and secure the antenna cable to the vehicle harness with one wire tie.

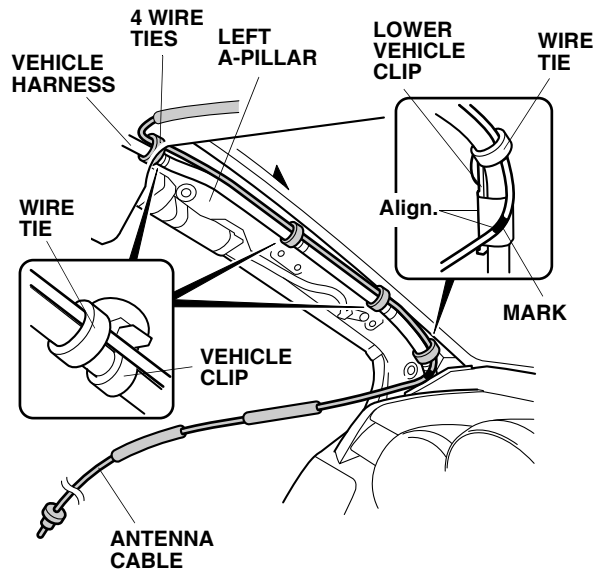

65. Secure the antenna cable to the vehicle harness with three wire ties at the locations shown.
66. Pull away the weatherstrip, and route the antenna cable down under the instrument panel. Tuck the antenna cable between the left A-pillar and the instrument panel, and reinstall the weatherstrip.

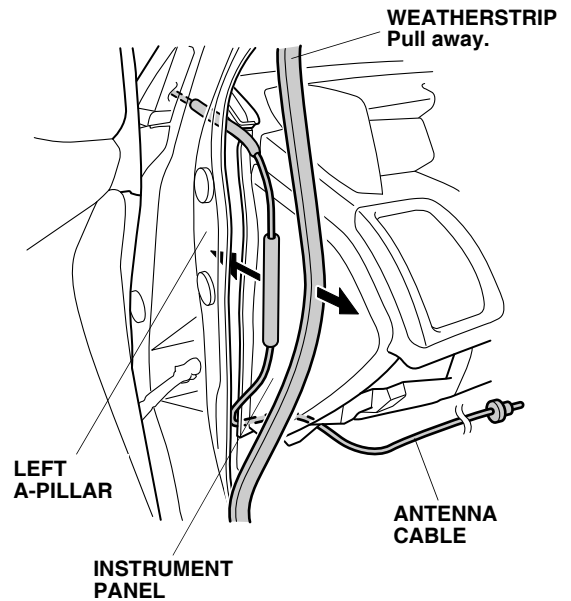

67. Under the instrument panel, secure the antenna cable to the vehicle harness with two wire ties.

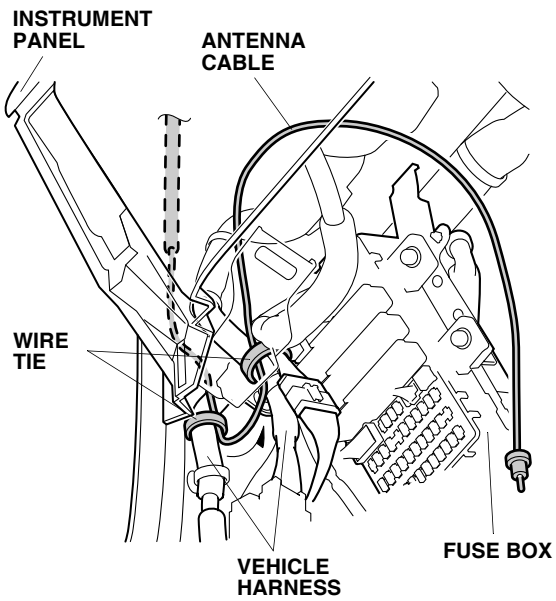

68. Continue routing the antenna cable to the engine starter harness relay block along the engine starter harness.

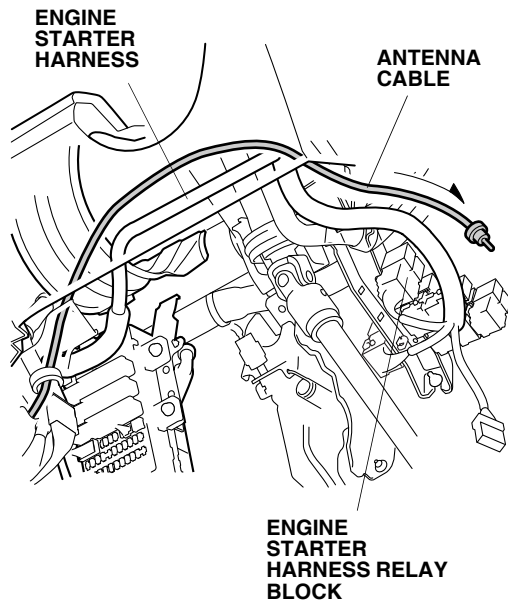

69. Plug the antenna cable terminal into the control unit.

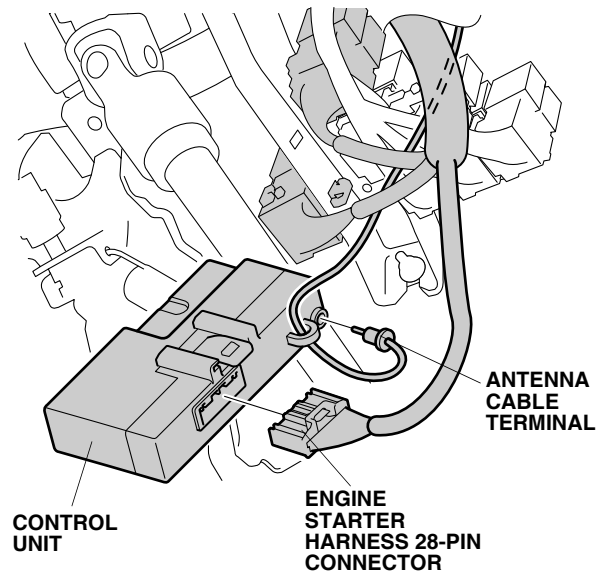

70. Plug the engine starter harness 28-pin connector into the control unit.
71. Slide the control unit bracket onto the control unit until it locks in place.

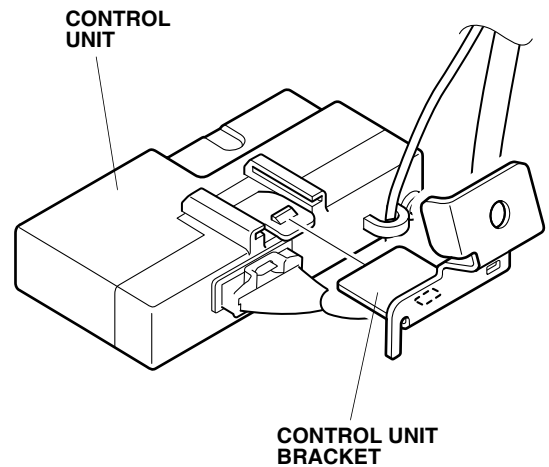

72. Remove the nut from the vehicle bracket, and install the control unit bracket onto the vehicle bracket.

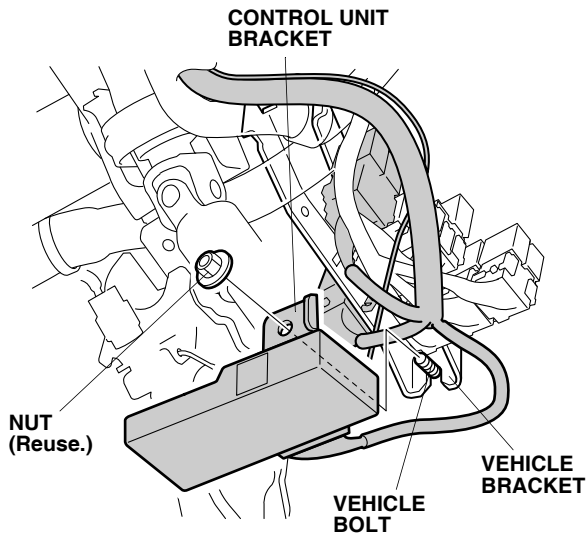

73. Starting at the control unit and working toward the fuse box, secure the engine starter harness and the antenna cable to the vehicle harness at the green tape with one wire tie.

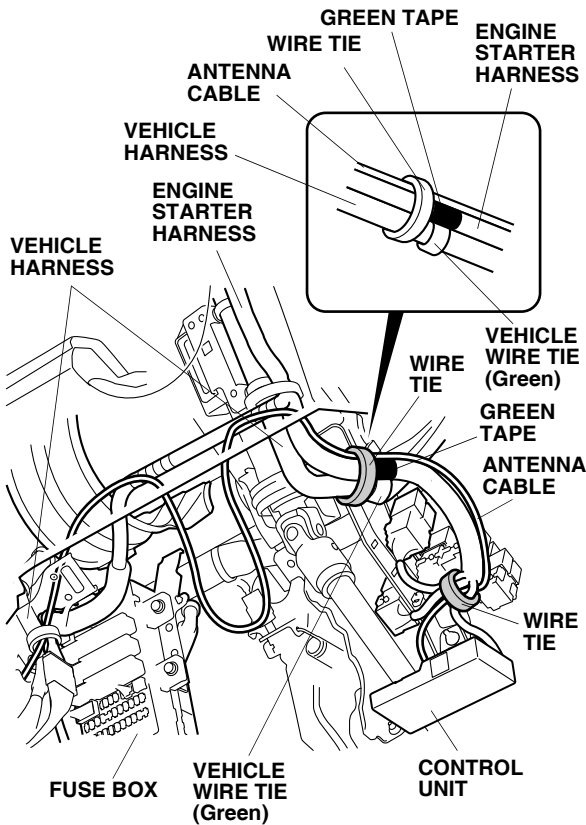

74. Continue routing the antenna cable toward the fuse box, and secure the antenna cable to the vehicle harness with one wire tie near the fuse box. Allow the excess harness to hang between the two wire ties.

75. Bundle the excess antenna cable and secure it to the engine starter harness with two additional wire ties in the areas shown.

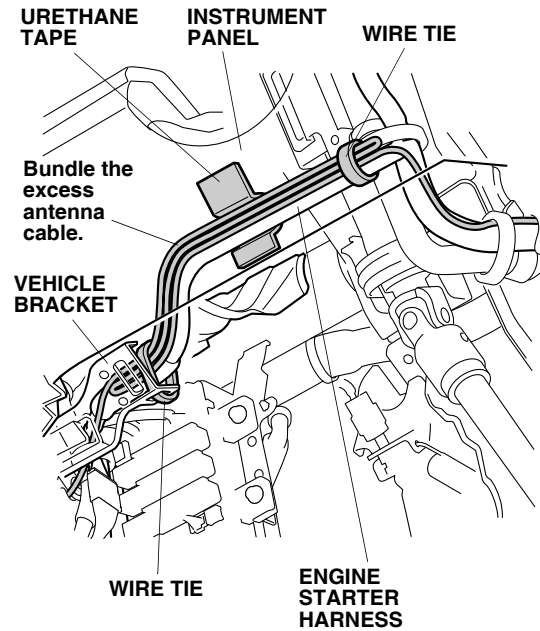

76. Using isopropyl alcohol on a shop towel, clean the instrument panel where the urethane tape will attach.
77. Using one urethane tape, secure the engine starter harness and antenna cable to the back of the instrument panel.

78. Under the hood, locate the area where the caution label will attach. Using isopropyl alcohol on a shop towel, clean the hood where the caution label will attach.

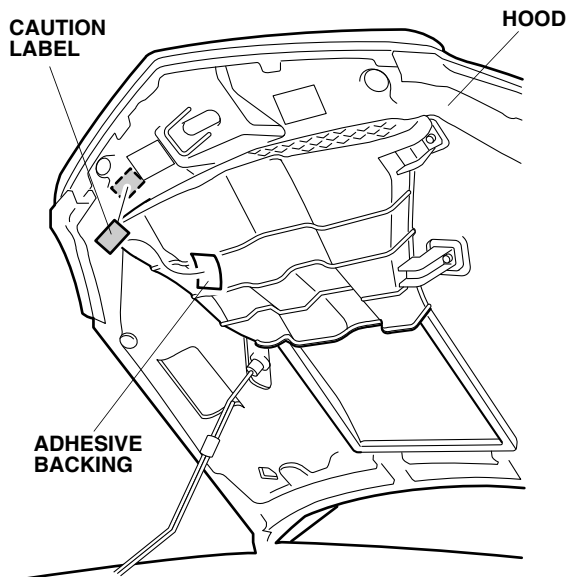

79. Attach the caution label to the hood in the area shown.
80. Reinstall all removed parts. Check that all clips and other fasteners are installed securely. Take care not to pinch the airbag with the clip during reinstallation of the A-pillar trim. Do not push excessively on the A-pillar trim.
81. Reconnect the negative cable to the battery.
82. Enter the client's audio unit anti-theft code, and reset the radio station presets.
83. Reset the clock.
84. Do the Remote Engine Starter Registration (page 20) and the Function Check (page 23).

Setting the Automatic Defrost Function (If Equipped with Automatic Climate Control)

- Turn the air conditioner OFF with the ignition switch in the ON (II) position, then turn the ignition switch to the LOCK (0) position.
- Press and hold both the REAR DEFOGGER switch and the RECIRCULATION switch, then turn the ignition switch to the ON (II) position for at least 10 seconds. The set temperature and a number (01 or 02) on the air conditioner display will blink after 5 seconds, and stay on after 10 seconds. The number 01 indicates that the automatic defrost function is OFF, and the number 02 indicates that the automatic defrost function is ON.

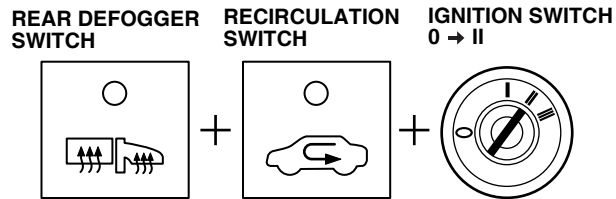

Appears in the A/C display

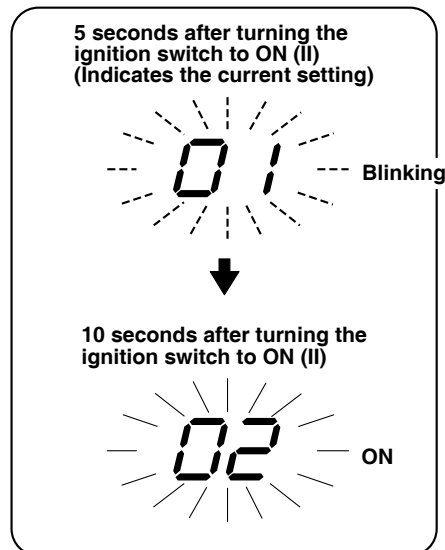

REMOTE ENGINE STARTER REGISTRATION

1. Acquire a PCM code from ISIS.

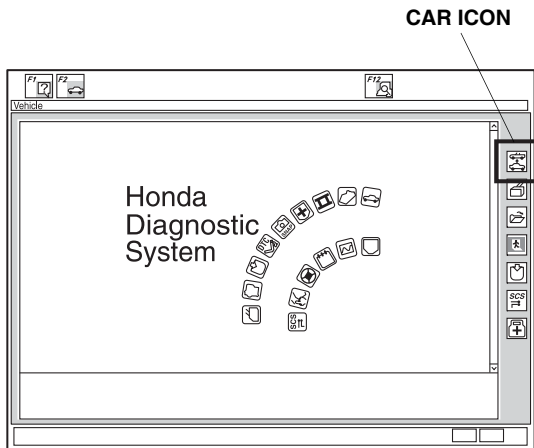

2. Connect the HDS tester to the OBD II data link connector, then turn the ignition switch to ON (II).
3. Start the HDS, and click the car icon.
4. Input the VIN and other required information into the HDS, then click the check button.

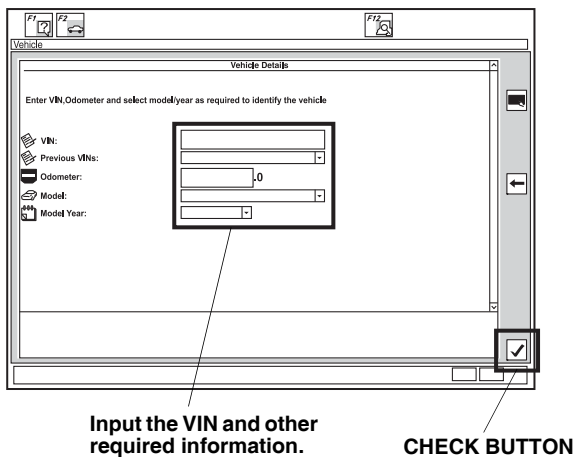

5. Select **Honda Systems**, then click the check button.

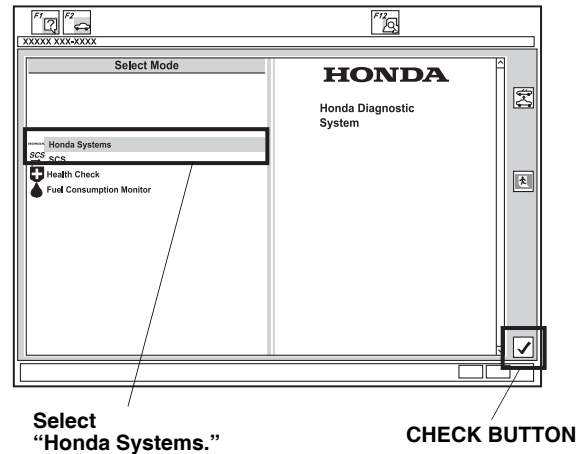

6. Select **R/C ENG STARTER** and click the check button.

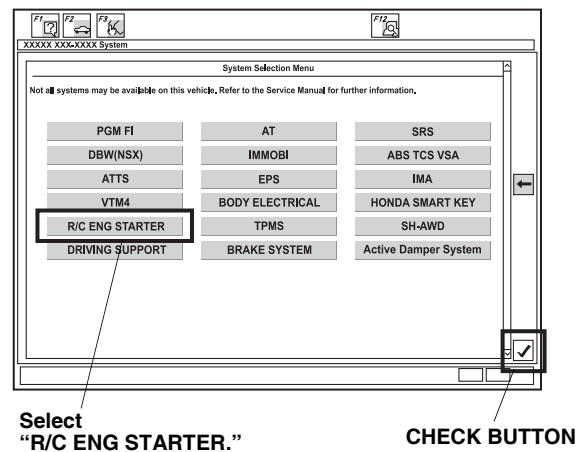

7. A **REMARKS** message will display. Click the check button.

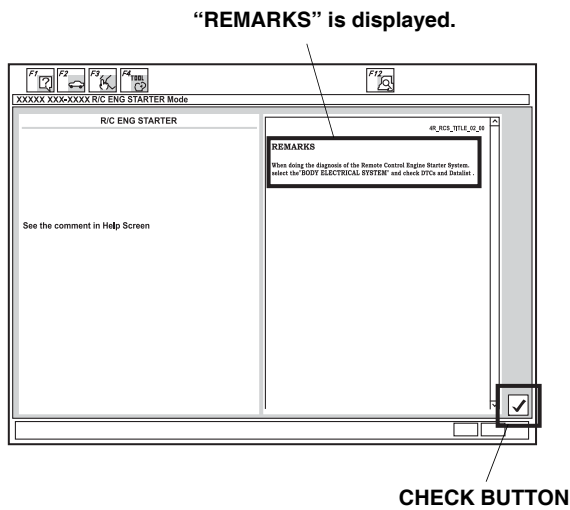

8. Select **REGISTER REMOTE CONTROL ENGINE STARTER UNIT**, then click the check button.

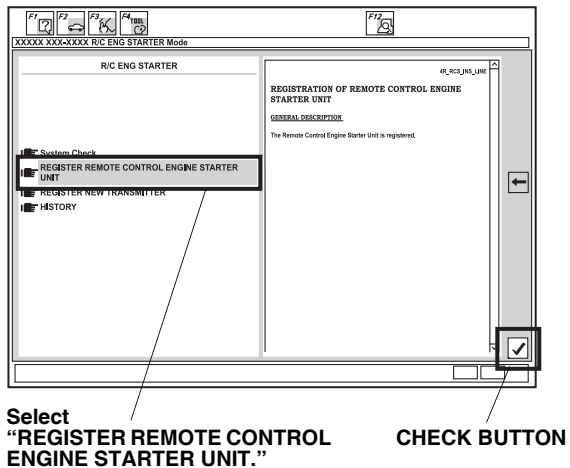

9. The following message will display: **Obtain PCM-code (IMMOBILIZER PCM CODE) from iN. This vehicle's VIN will be required to obtain the password. (USA).** Click on the check button.

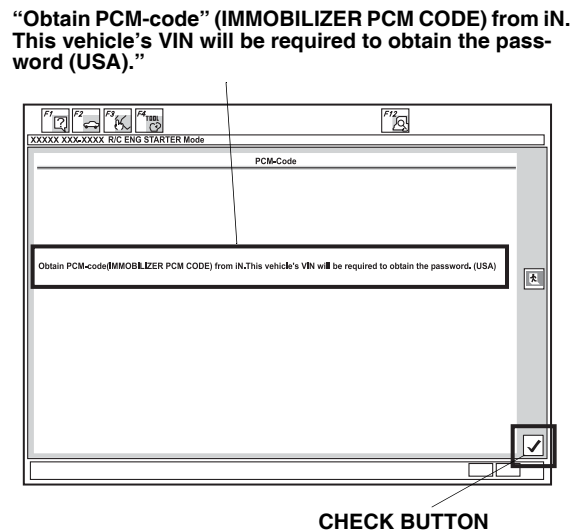

10. Input the PCM code, then click the check button. **NOTE:** To ensure security, the PCM code (password) is changed every day, so it is impossible to register the remote control engine starter if the dates of the PCM code acquisition and registration are different. The date of the HDS tester should also be the same.

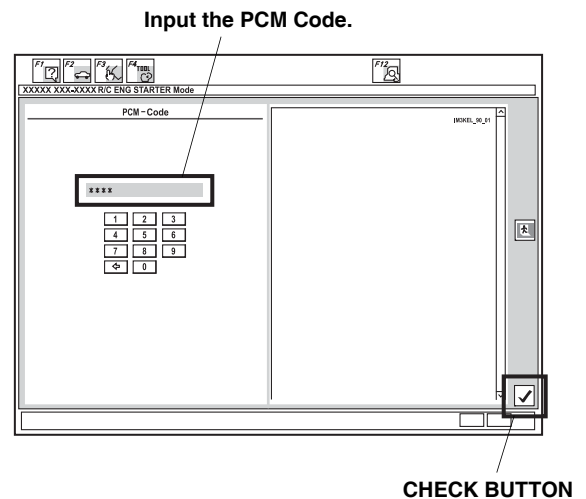

11. The following message will display: **The registration of the Remote Control Engine Starter Unit has been completed.** Click on the check button.

“The registration of the Remote Control Engine Starter Unit has been completed.”

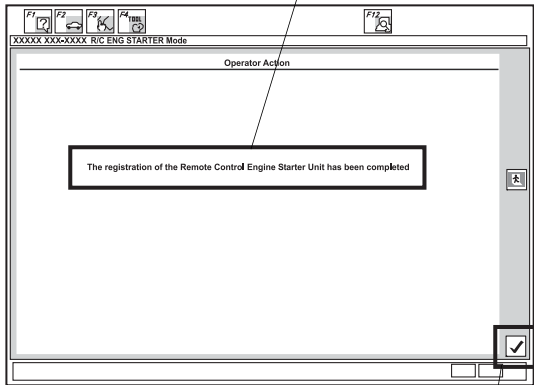

CHECK BUTTON

12. The following message will display: **Check that the engine can be started by the Transmitter.** Click on the check button.

“Check that the engine can be started by the Transmitter.”

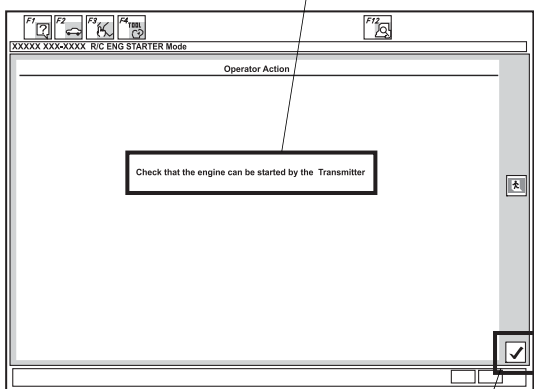

CHECK BUTTON

13. Perform the Function Check on the next page, then disconnect the HDS.

FUNCTION CHECK

Operating Conditions

- Hood is closed
- Shift lever is in park
- The key is out of the ignition switch
- All doors and tailgate are closed and locked

Inspection

1. Press the command button, and then, within 1 second, press the start button on the transmitter.
The engine should start if all operating conditions are met.

Does the engine start?

| |
|--|
| Yes - Operation is normal. |
| No: <ul style="list-style-type: none">• Check for DTCs.• Make sure all "Operating Conditions" are met.• Check the engine starter harness connections.• Connect the HDS and check for an indicated failure. (Refer to the appropriate service manual for details.) |

2. Press the command button on the transmitter, and within 1 second, press the stop button. The engine should stop.

Does the engine stop?

| |
|--|
| Yes - Operation is normal. |
| No - Check the engine starter harness connections. |

3. After the engine has stopped, start the engine again, and check that the engine stops after each of the following conditions:

NOTE: After each test, the ignition key must be cycled or the driver's door must be opened and closed.

- Move the shift lever out of the P position.
- Unlock or open the doors or the tailgate.
- Open the hood.
- Insert the key in the ignition switch.
- Press on the brake pedal.

Does the engine stop after each of these tests?

| |
|--|
| Yes - Operation is normal. |
| No - Check the engine starter harness connections. |

4. Verify that the power windows and the moonroof can not be opened when the engine is started with the transmitter.
5. Press the command button on the transmitter twice and check the vehicle condition on the display.
6. Check the operation of the transmitter when the vehicle is 60 m (200 ft.) away, and in direct sight.

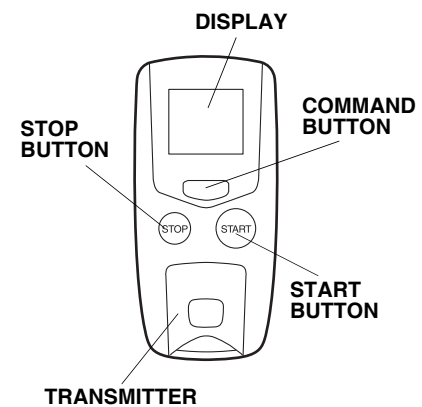

How to Program an Additional Transmitter

1. Connect the HDS to the data link connector.
2. Start the HDS and click on the car icon.
3. Input the vehicle's VIN and other required information.
4. Select **Honda Systems**.
5. Select **R/C Engine Starter**.
6. Select **REGISTER NEW TRANSMITTER**.
7. When "Ready to program the new transmitter" shows, select **ENTER**.
8. Press and release the Command button.
9. Press and release the Stop button.
10. Perform the function check on both transmitters.

NOTE: Only 2 remotes can be stored in the system's memory.