



INSTALLATION INSTRUCTIONS

Accessory

STEERING WHEEL

Application

2011 MDX

Publications No.

BII 43685

Issue Date

AUG 2010

PARTS LIST

Steering wheel

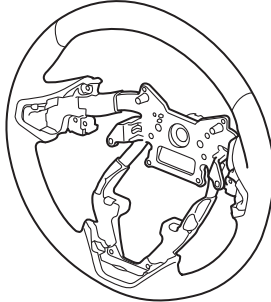

2 TORX bolts

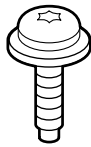

Important Information

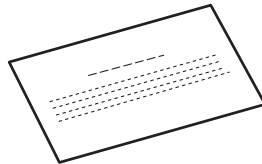

TOOLS AND SUPPLIES REQUIRED

Phillips screwdriver

19 mm T-handle wrench

10 mm Combination wrench

Ratchet

Torque wrench

T30 TORX bit

Steering wheel puller

Tape measure

Plastic Trim Tool (T/N SILTRIMTL10)

Duct tape

Service Manual

INSTALLATION

Client Information: The information in this installation instruction is intended for use only by skilled technicians who have the proper tools, equipment, and training to correctly and safely add equipment to your vehicle. These procedures should not be attempted by “do-it-yourselfers.”

NOTE:

- Observe all safety notes and precautions described in the service manual in addition to those described in this installation instruction.
- After installing the steering wheel, you must align the steering wheel spoke angle to the straight-ahead position by adjusting the front toe.
 1. Make sure you have the anti-theft codes for the radio and navigation system (if equipped), then write down the radio presets.
 2. Disconnect the negative cable from the battery, and wait for at least 3 minutes before beginning to install the steering wheel.

3. Pry on the four retaining tabs, and remove the access panel.

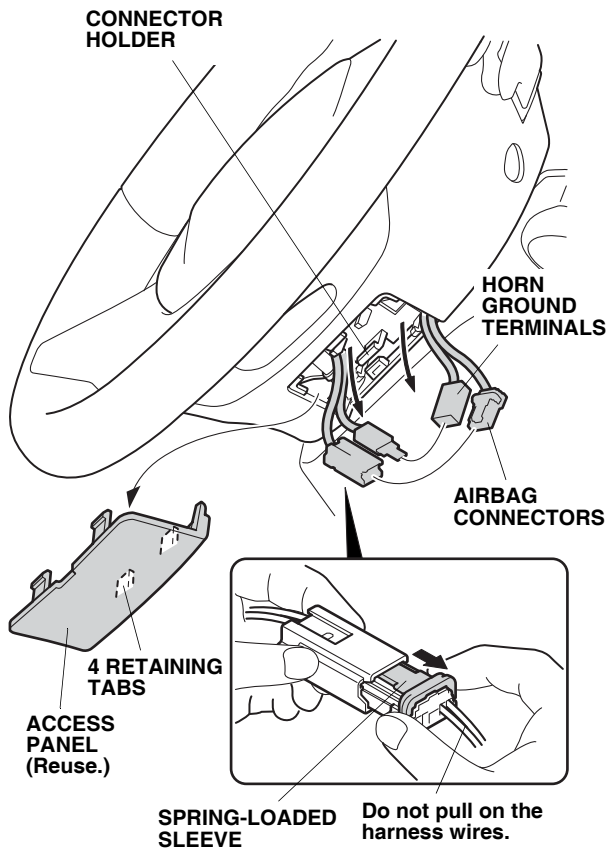

4. Remove the horn ground terminals and the airbag connectors from the connector holder. Unplug the horn ground terminals.
5. Unplug the airbag connectors. To release the lock, pull the spring-loaded sleeve towards the stop while holding the opposite half of the airbag connector. Then pull the airbag connector halves apart. Make sure to pull on the sleeve and not on the airbag connector.

6. Attach duct tape to the area shown.

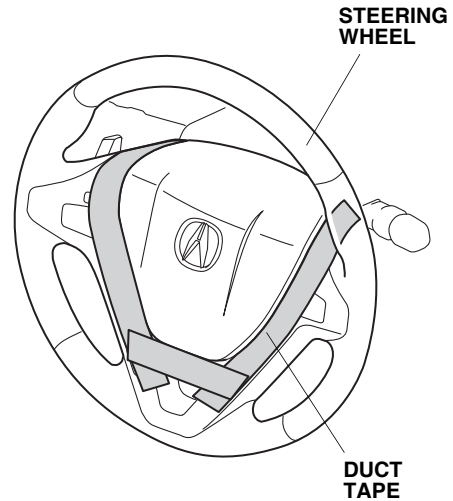

7. Remove and discard the two TORX bolts that secure the airbag, and remove the airbag. Carefully set the airbag in a secure location with the pad facing up. Do not drop or bump the airbag against anything.

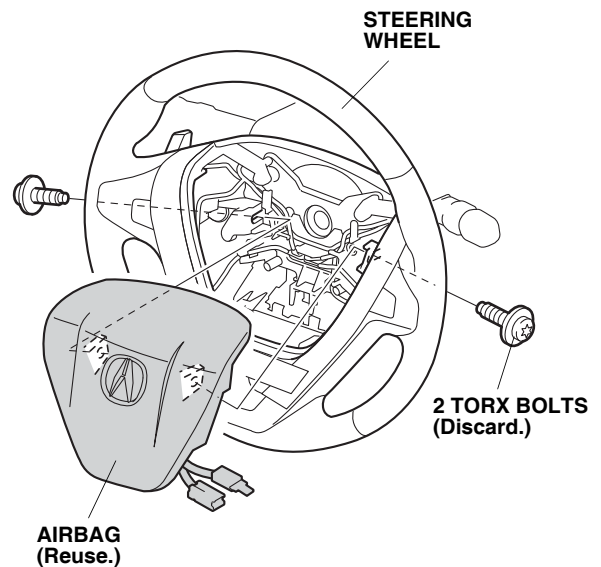

8. Turn the steering wheel so the front wheels are in the straight-ahead position.

- Remove the steering wheel bolt. Unplug the 20-pin connector from the cable reel. Using a steering wheel puller, remove the steering wheel. Do not thread the steering wheel puller bolts in more than 10 mm (0.4 in.). Be careful not to move the steering wheel during removal. Route the airbag connector through the steering wheel opening.

NOTE: Be careful not to damage the wiring with the steering wheel puller.

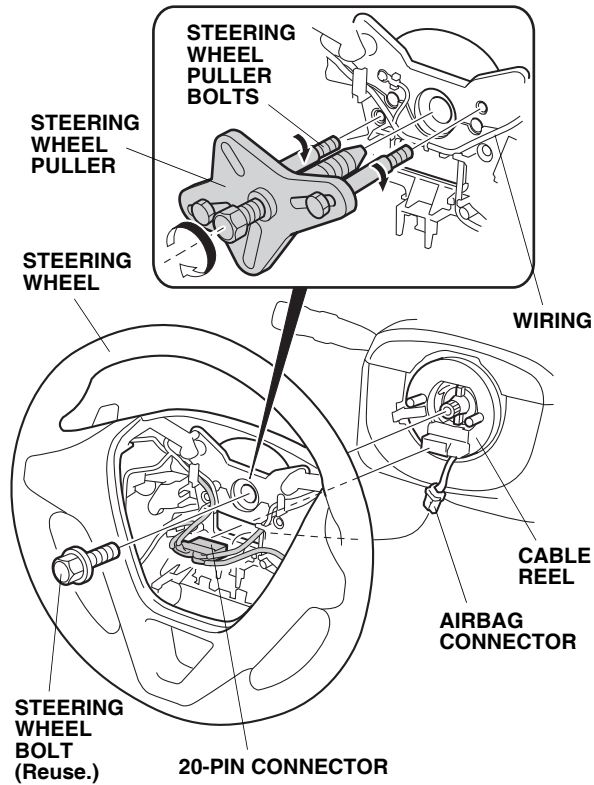

- Remove the six self-tapping screws that fasten the steering wheel rear cover and lower cover to the steering wheel, then remove the steering wheel rear cover and lower cover.

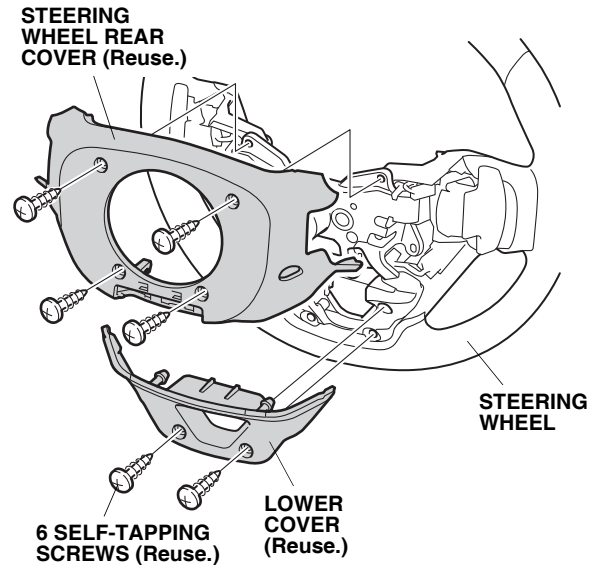

- Remove the four screws from the left and right paddle switches.

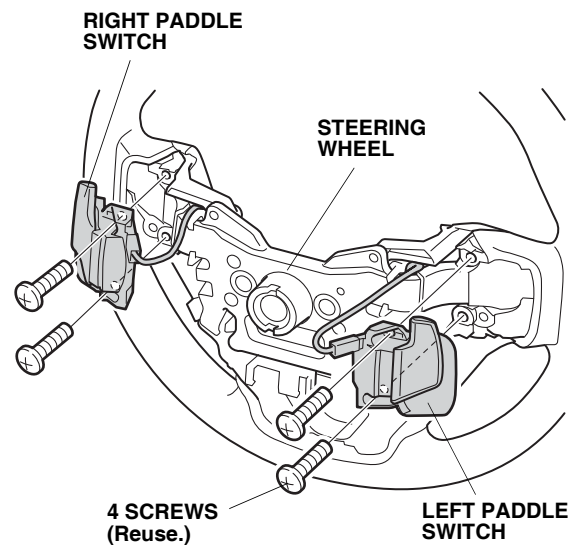

12. Remove the two self-tapping screws from the steering wheel.

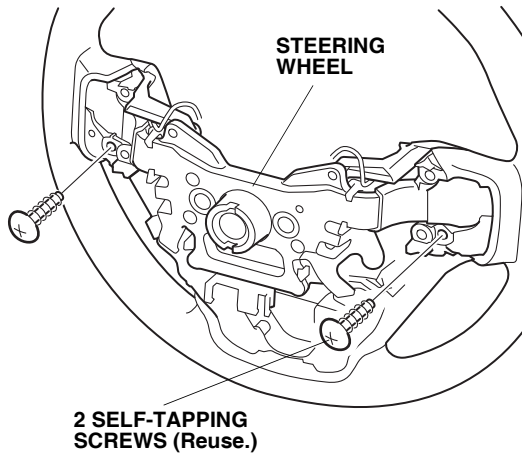

13. Release the wiring from the retaining tab, and remove the screw that secures the ground wire to the connector holder.

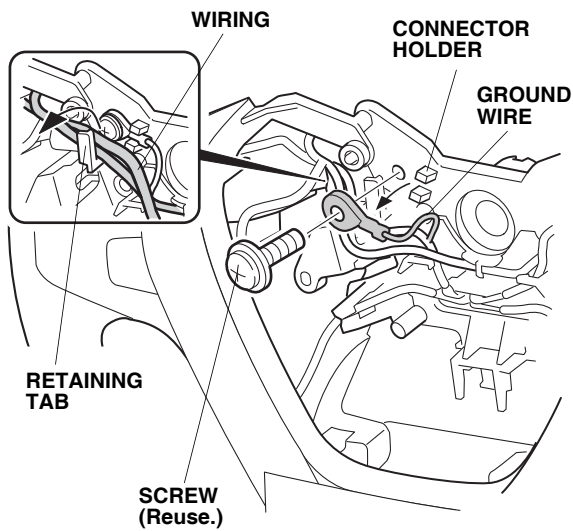

14. Remove the steering wheel trim by releasing the wiring from the seven retaining tabs.

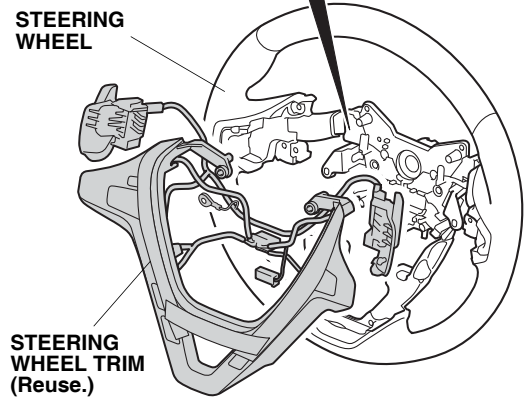
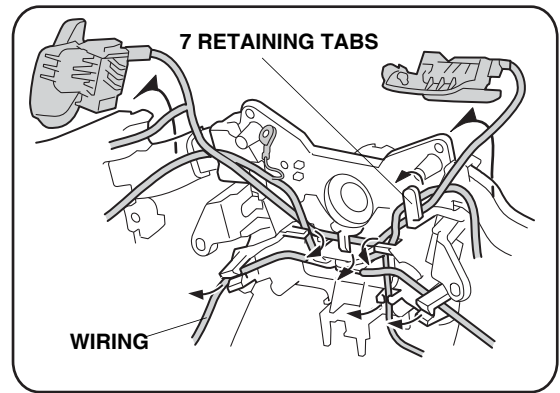

15. Pry up the six retaining tabs, and remove the connector holder from the steering wheel.

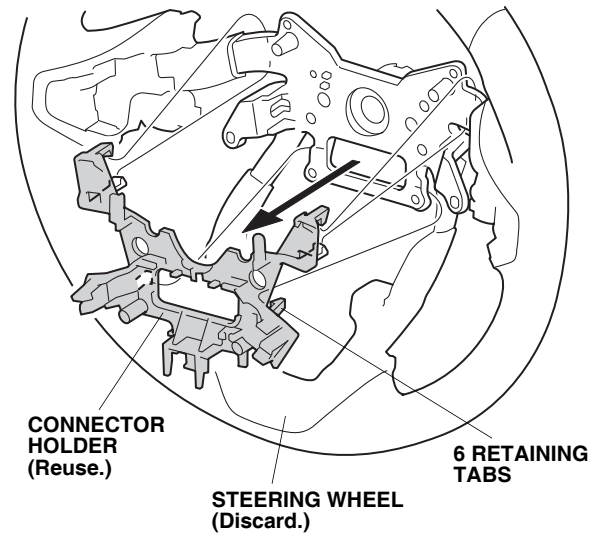

16. Install the connector holder on the new steering wheel.

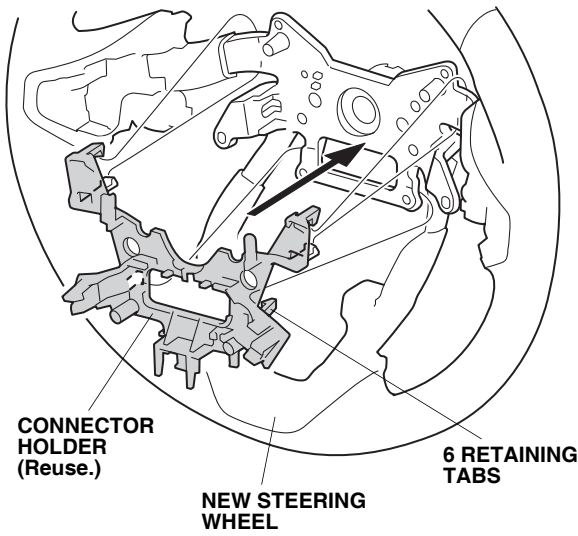

17. Position the steering wheel trim to the new steering wheel, and attach the wiring to the seven retaining tabs.

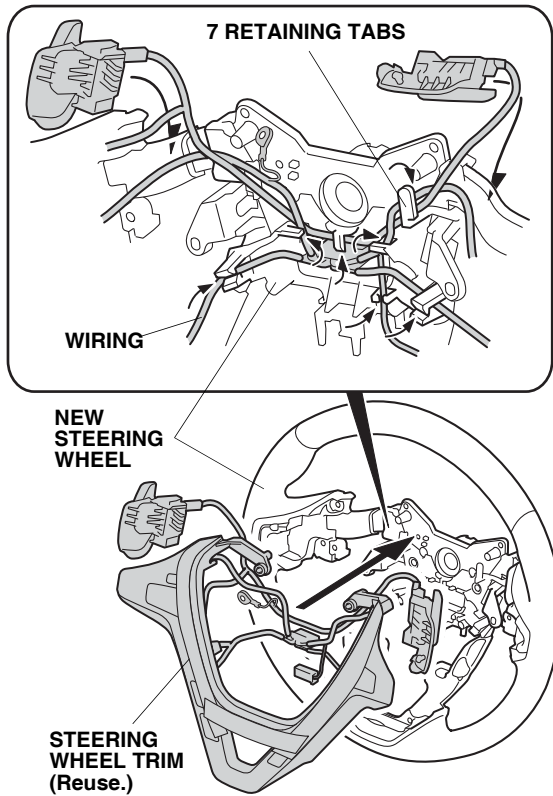

18. Secure the ground wire with the screw, and attach the wiring to the retaining tab.

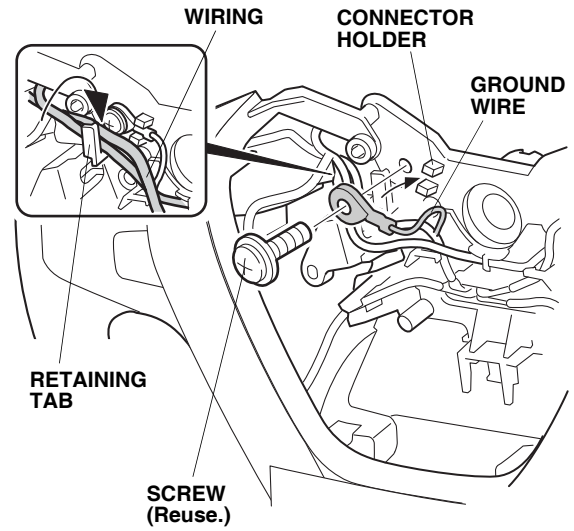

19. Make sure there is equal clearance on the right and left sides of the steering wheel trim, and that the leather is completely covered at the positions shown.

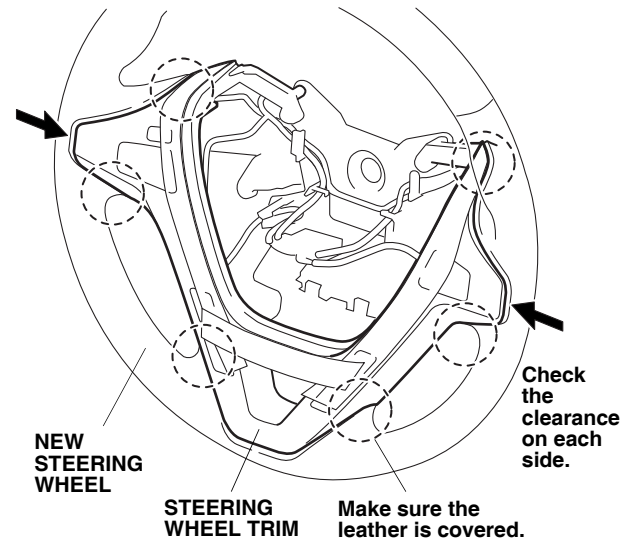

20. Install the two self-tapping screws into the new steering wheel.

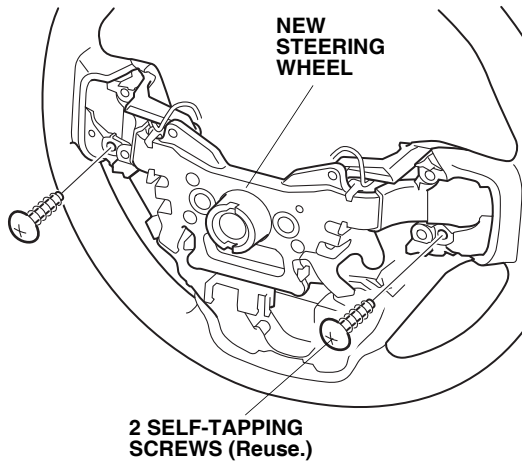

21. Install the left and right paddle switches to the new steering wheel using four screws.

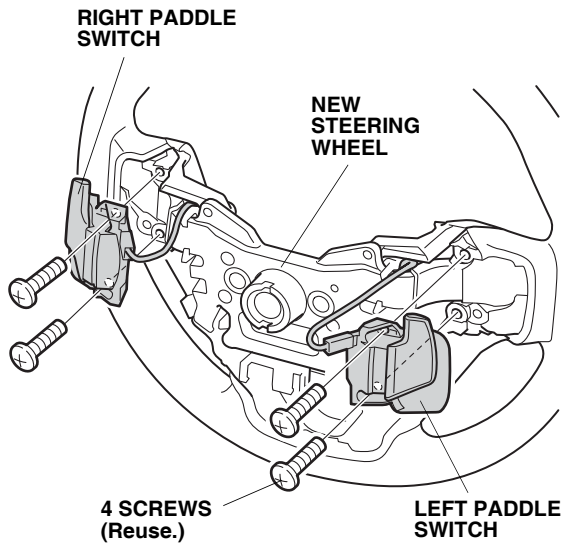

22. Install the steering wheel rear cover and lower cover to the new steering wheel with the six self-tapping screws.

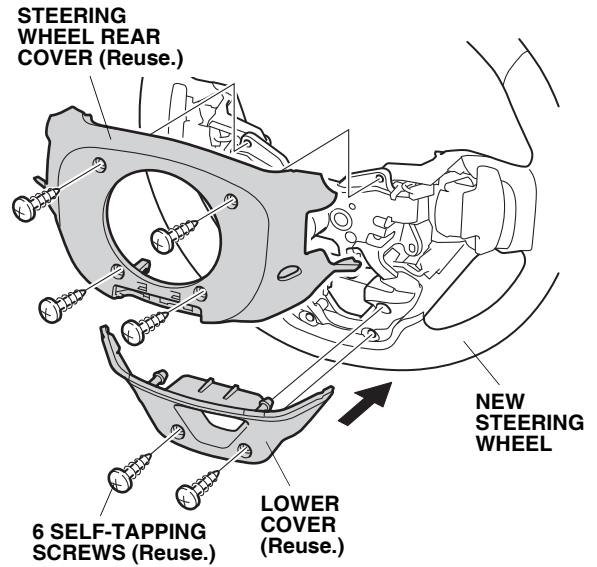

23. Install the new steering wheel on the steering column shaft in the straight-ahead position:
- Route the airbag connector through the opening in the new steering wheel.
 - Align the two tabs of the canceling sleeve with the two cutouts in the new steering wheel as shown.
 - Make sure the wire harness is not pinched.

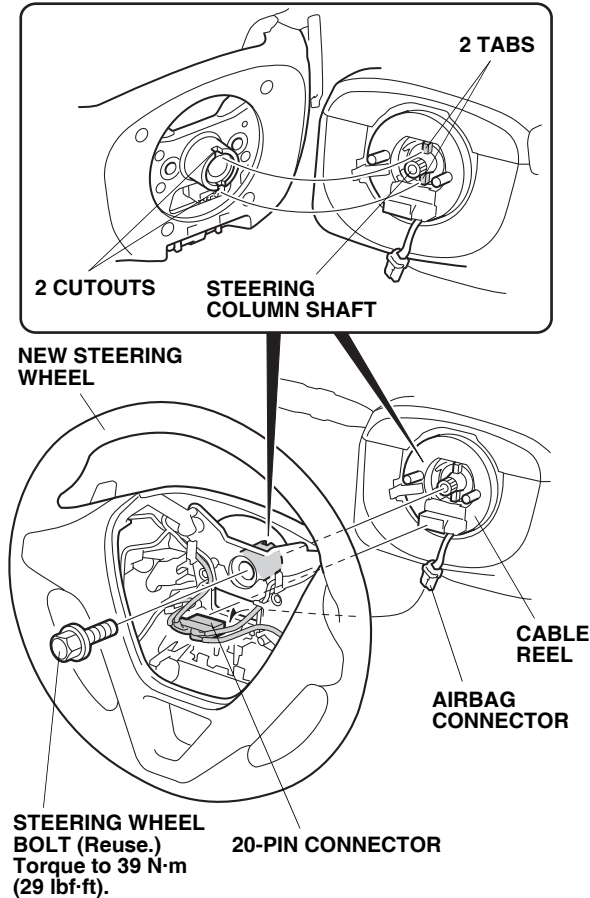

24. Install the steering wheel bolt. Torque the steering wheel bolt to 39 N·m (29 lbf·ft).
25. Plug the 20-pin connector into the cable reel.

26. Route the airbag connector and horn ground terminal down through the new steering wheel. Position the airbag on the new steering wheel, and install the two new TORX bolts. Torque the TORX bolts to 10 N·m (7.4 lbf·ft). Make sure the harnesses are not pinched.

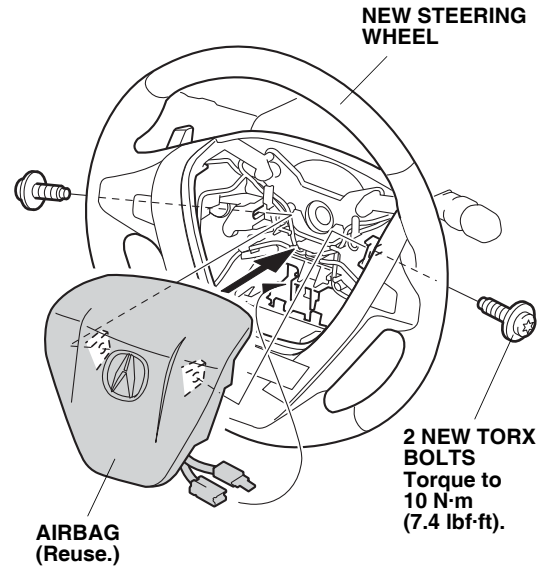

27. Connect the horn ground terminals, and reattach the horn ground terminals to the connector holder.

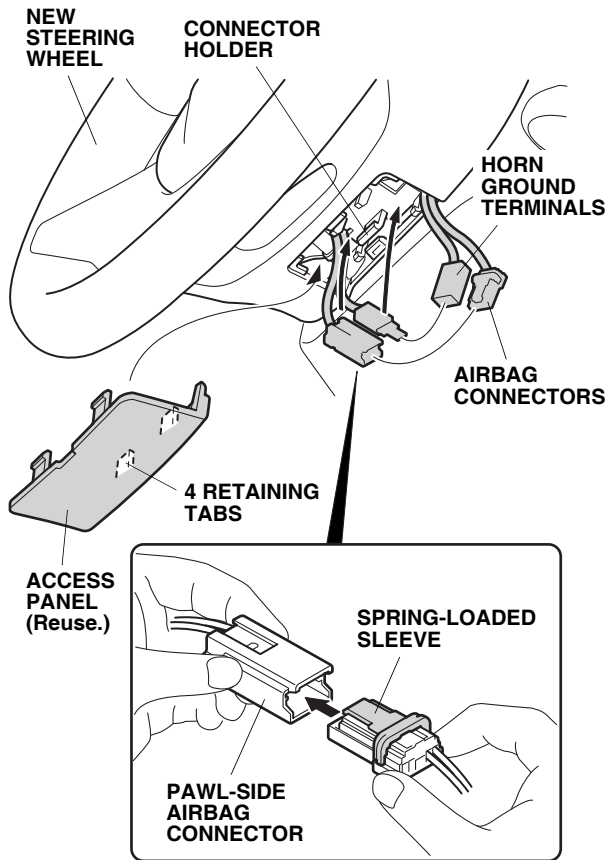

28. Reconnect the airbag connectors. To reconnect, hold the pawl-side of the airbag connector, and press on the back of the sleeve-side airbag connector as shown. As you push the two airbag connector halves together, the sleeve is pushed back by the pawl. Do not touch the sleeve.
29. Reattach the airbag connectors to the connector holder.
30. Reinstall the access panel, and remove the duct tape attached in step 6.

31. Reconnect the negative cable to the battery, and do these tasks:
- Turn the ignition switch to ON (II); the SRS indicator should come on for about 6 seconds and then go off.
 - Enter the anti-theft code for the audio system and the navigation system (if equipped), and enter the radio presets.
 - Make sure the horn and turn signal switches work properly.
 - Make sure the steering wheel switches work properly.
32. Reset the steering column position memorization:
- Insert the built-in key into the ignition switch, and remove it.
 - The steering wheel automatically moves fully in and up to let you know the system is reset.
33. Reset the clock (without navigation).
34. Make sure the steering wheel is in the straight-ahead position when the front wheels are straight ahead. If the spoke angle of the steering wheel is off, adjust the front toe as described in the service manual.