



INSTALLATION INSTRUCTIONS

Accessory
SIDE STEPS
P/N 08L33-STX-200E

Application
2011 MDX

Publications No.
BII 43681
Issue Date
AUG 2010

PARTS LIST

Right side step

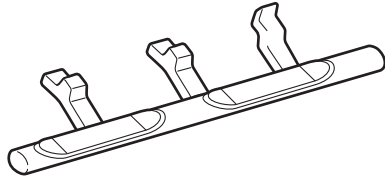

Left side step

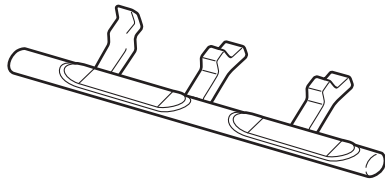

24 Flange bolts



TOOLS AND SUPPLIES REQUIRED

Ratchet
13 mm Socket
Torque wrench
Scraper

INSTALLATION

Client Information: The information in this installation instruction is intended for use only by skilled technicians who have the proper tools, equipment, and training to correctly and safely add equipment to your vehicle. These procedures should not be attempted by "do-it-yourselfers."

NOTE:

- Thoroughly clean the bottom of the body between the front and rear wheels.
- Be careful not to damage the body paint finish.
- These instructions show the left side step being installed; the same procedure applies to installing the right side step.

1. Position the three brackets on the vehicle frame. Install the brackets on the vehicle frame with 12 flange bolts. Do not tighten the flange bolts yet. Make sure the flange bolts are installed in the correct positions.

NOTE: If there is undercoat on the body surface where the brackets will attach, use a scraper to remove the undercoat before installing the brackets. If necessary, clean the threads using a tap. Take care not to damage the paint finish.

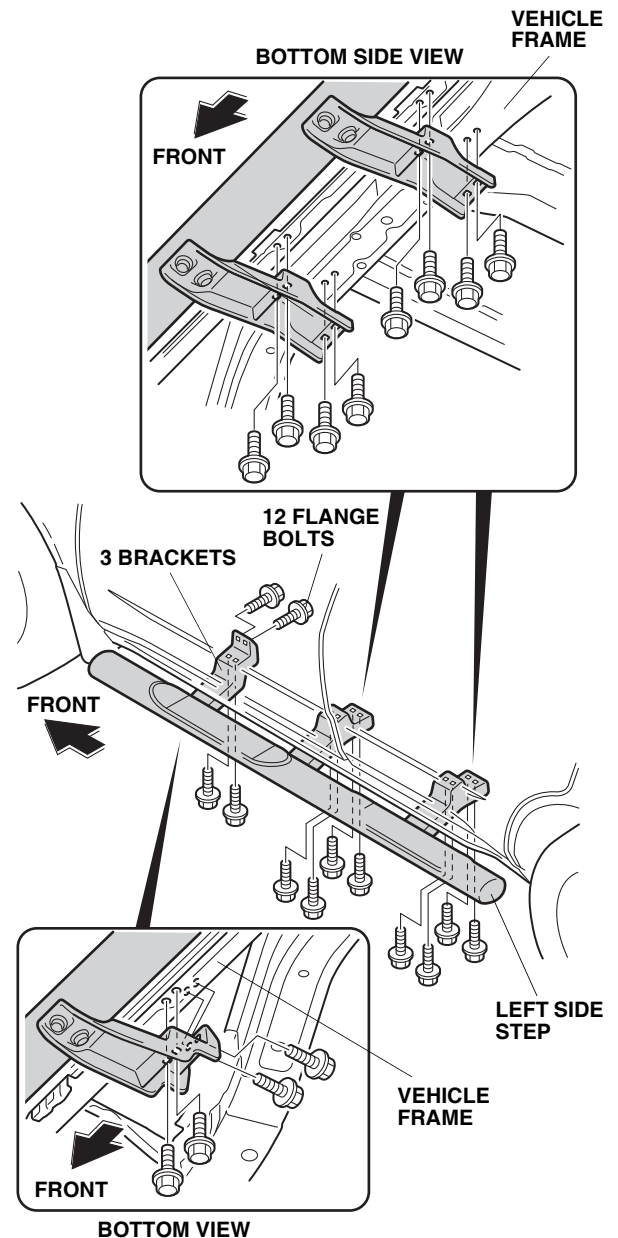

2. Torque the six flange bolts already attached to the left side step to 27 N·m (20 lbf·ft).

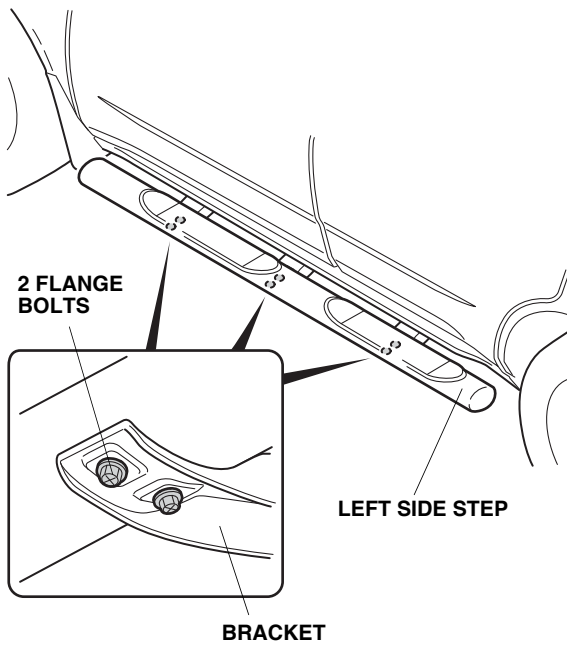

3. Torque all the flange bolts you installed in step 1 to 27 N·m (20 lbf·ft).
4. Repeat steps 1 through 3 to install the side step on the right side of the vehicle.