



INSTALLATION INSTRUCTIONS

Accessory
REAR LOWER TRIM
P/N 08P46-STX-200C

Application
2011 MDX

Publications No.
BII 43675
Issue Date
AUG 2010

PARTS LIST

Rear lower trim

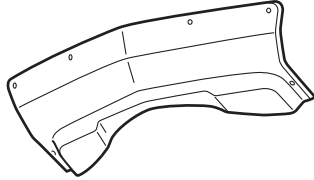

Rear lower molding

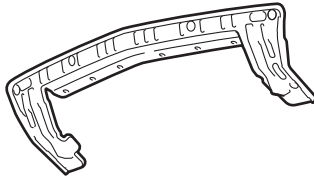

6 Special bolts



6 Washers



6 Rivet nuts



4 Self-tapping screws



TOOLS AND SUPPLIES REQUIRED

Phillips screwdriver

Clip remover

Ratchet

19 mm Socket

5 mm Hex bit

Torque wrench

19 mm Wrench

Drill

3 mm and 9 mm Drill bits

File

Gloves

Eye protection (face shield, safety goggles, etc.)

6 mm Rivet Nut Tool (T/N 07AAE-STX-A100)

Service Manual

INSTALLATION

Client Information: The information in this installation instruction is intended for use only by skilled technicians who have the proper tools, equipment, and training to correctly and safely add equipment to your vehicle. These procedures should not be attempted by "do-it-yourselfers."

NOTE:

- Be careful not to damage the rear bumper or other surfaces of the body.
 - The rear lower trim cannot be installed on a vehicle equipped with a trailer hitch.
1. Lift or jack up the vehicle as described in the service manual.

2. While wearing gloves, remove the 10 clips that fasten the rear bumper trim to the rear bumper, then remove the rear bumper trim from the rear bumper.

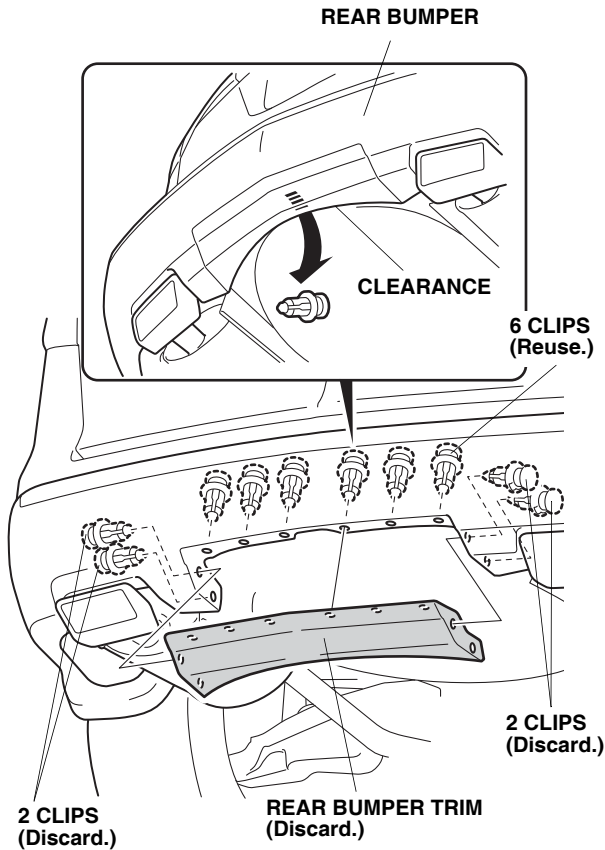

3. Install the rear lower molding to the rear bumper with six clips.

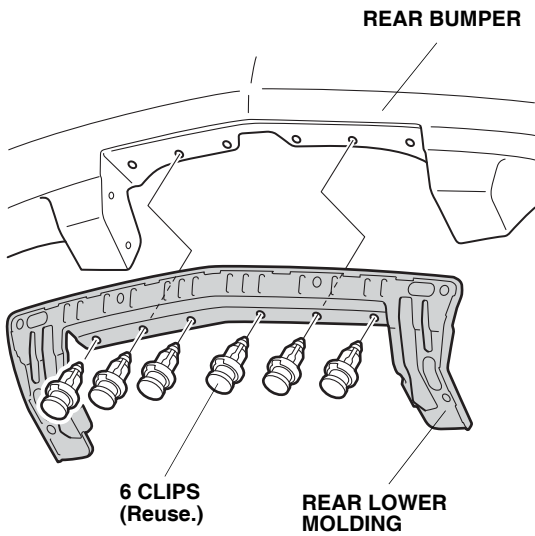

4. While wearing eye protection, hold the rear lower molding against the rear bumper and drill holes through the center of the four dimple marks with a 3 mm drill bit. Remove any burrs from the edges of the holes with a file.

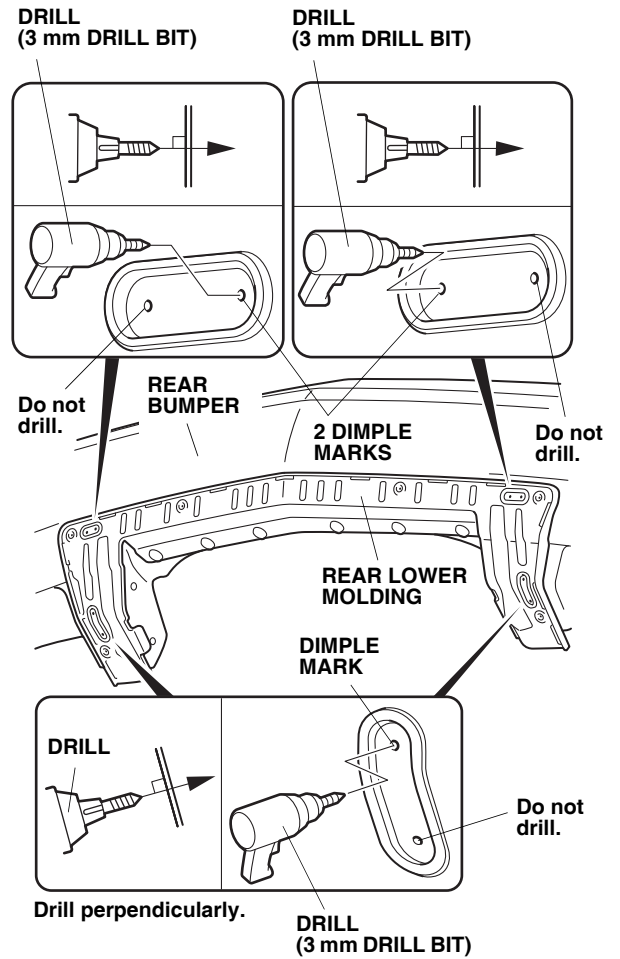

- While holding the rear lower molding against the rear bumper, install four self-tapping screws in the order shown.

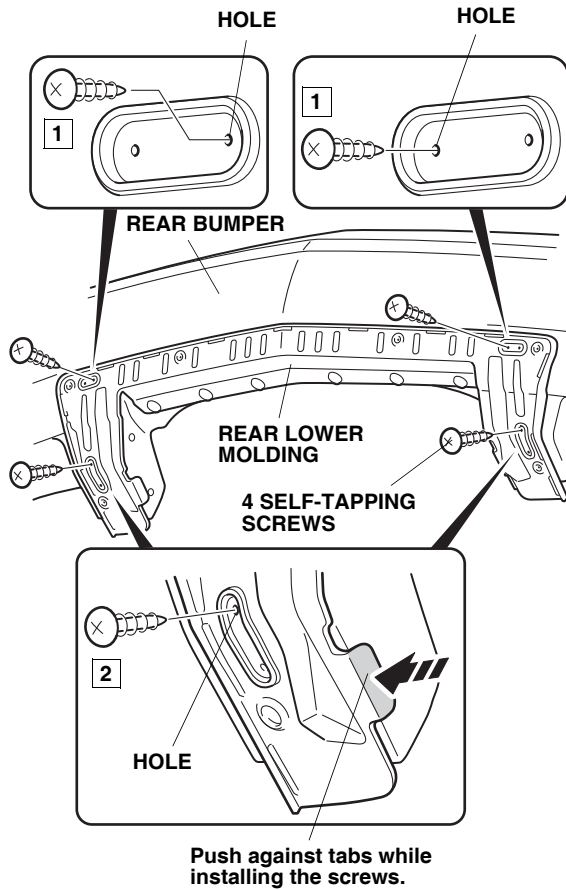

- Push the outside edge of the rear lower molding to make sure there is no gap.

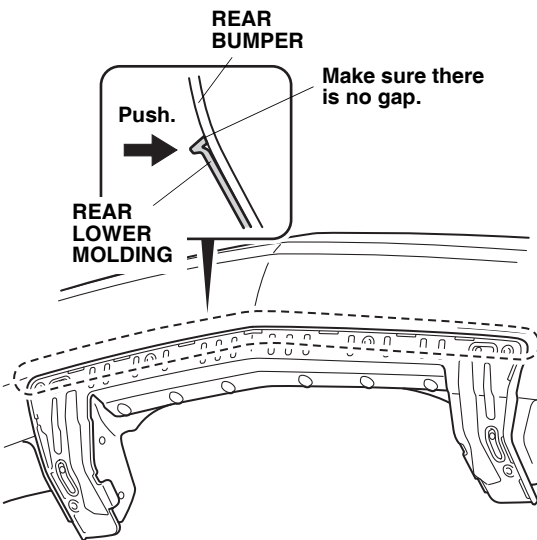

NOTE: If a gap is found at the outside edge of the rear lower molding, remove the self-tapping screws and realign the rear lower molding. Repeat step 4 to drill in the four alternate locations, and then reinstall the self-tapping screws in the alternate locations.

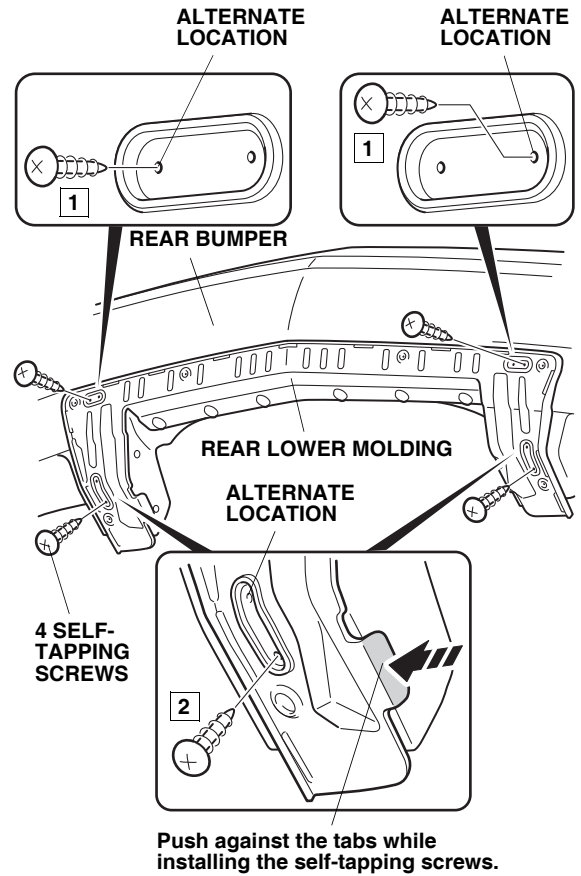

7. While wearing eye protection, drill holes through the centers of the six dimple marks. First drill with a 3 mm drill bit, then finish with a 9 mm drill bit. Remove any burrs from the edges of the holes with a file.

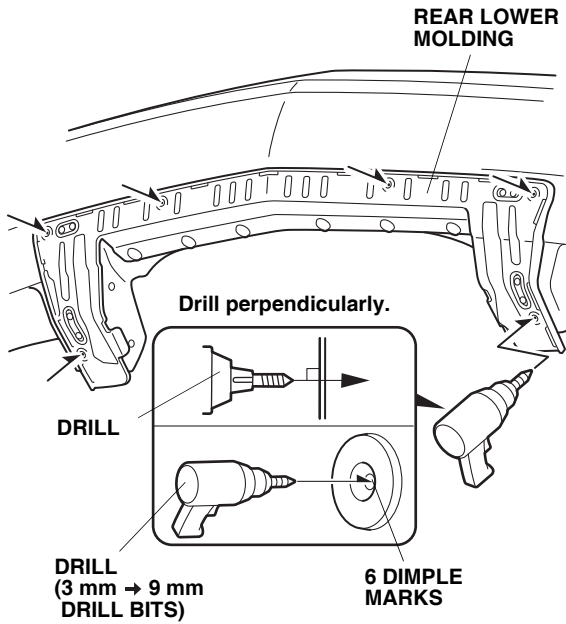

8. Install six rivet nuts in the holes in the positions shown. Follow steps 9 through 13.

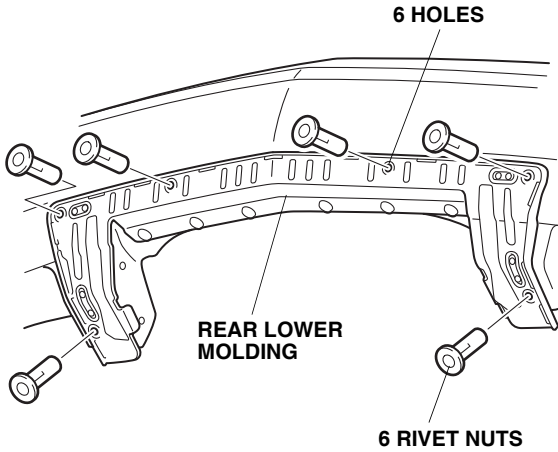

9. Turn the nut counterclockwise until the stud is fully extended.

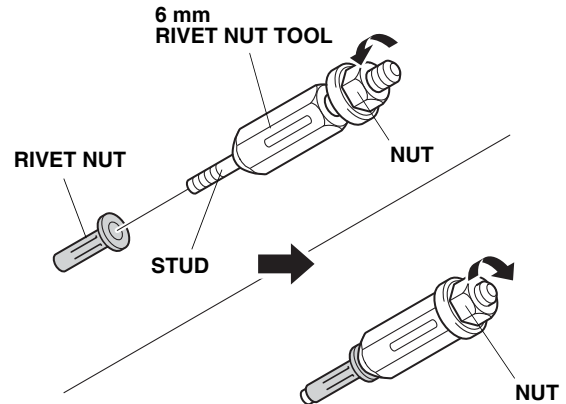

10. Thread the rivet nut fully onto the tool.
11. Insert the rivet nut into the hole. Place a 19 mm wrench on the tool body, and hold it stationary with a 19 mm ratchet wrench on the nut.

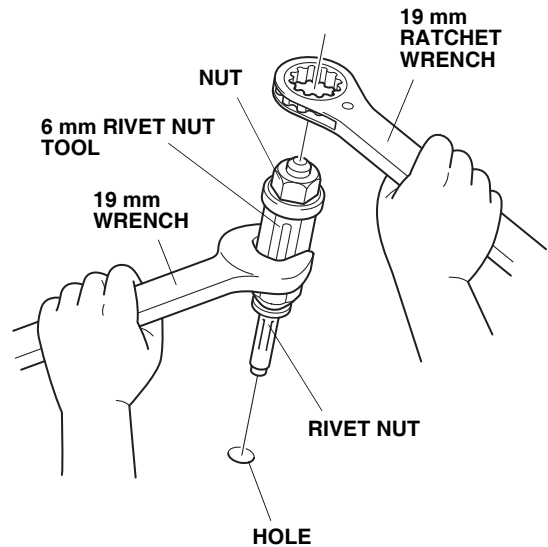

- Turn the 19 mm ratchet wrench clockwise while holding the tool perpendicular to the work. Turn the nut until firm resistance is felt. Several turns will be required.

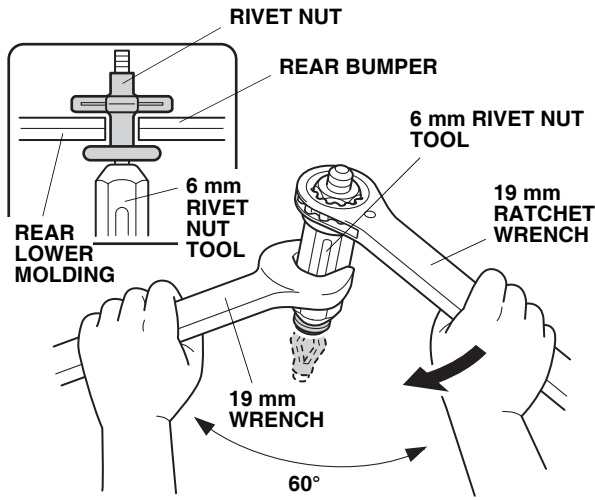

- Remove the rivet nut tool from the rivet nut by turning the tool body in a counterclockwise direction.

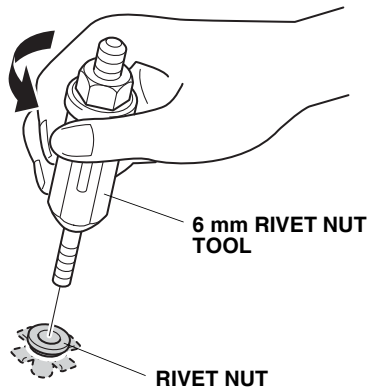

- Position the rear lower trim over the rear lower molding, and secure it with six washers and six special bolts. Torque the special bolts to 6 to 9 N·m (4.4 to 6.5 lbf·ft).

