



# INSTALLATION INSTRUCTIONS

Accessory  
**ENGINE BLOCK HEATER**  
P/N 08T44-SNA-101

Application  
**2011 MDX**

Publications No.  
**BII 43667**  
Issue Date  
**AUG 2010**

## PARTS LIST

Engine block heater

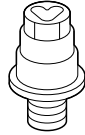

Aluminum washer



Heater harness

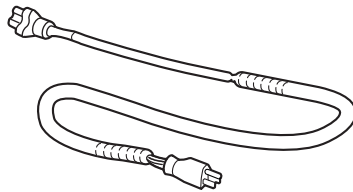

Protective cap

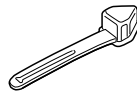

12 Black wire ties  
(1 Not used)

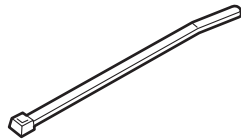

7 Wire ties with clip  
(7 Not used)

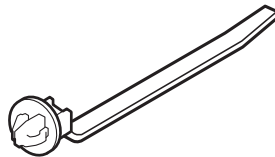

5 White wire ties  
(3 Not used)

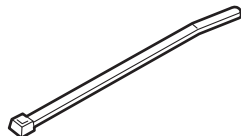

## TOOLS AND SUPPLIES REQUIRED

Phillips screwdriver

Flat-tip screwdriver

Ratchet

10 mm and 24 mm Sockets

Torque wrench

Diagonal cutters

Extension

Heavy gloves

Drain pan

Felt-tip pen

Tape measure

White marker

Coolant (Honda All Season Antifreeze/Coolant Type2)

Fender cover

Shop towel

Blanket

## INSTALLATION

### NOTE:

- Always use Honda All Season Antifreeze/Coolant Type2. Using a non-Honda coolant can result in corrosion, causing the cooling system to malfunction or fail.
- To avoid burning out the element, do not operate the engine block heater until it is installed in the vehicle and you have added coolant.

**Client Information:** The information in this installation instruction is intended for use only by skilled technicians who have the proper tools, equipment, and training to correctly and safely add equipment to your vehicle. These procedures should not be attempted by "do-it-yourselfers."

1. Make sure you have the anti-theft codes for the audio and navigation system (if equipped), then write down the audio presets.
2. Allow the engine and all cooling system components to cool down.
3. Place a clean drain pan under the radiator drain plug, then remove the drain plug from the bottom of the radiator to drain the coolant. Remove the cover and the radiator cap to increase the flow.

**NOTICE:** Radiator coolant will damage paint. Quickly rinse any spilled coolant from painted surfaces.

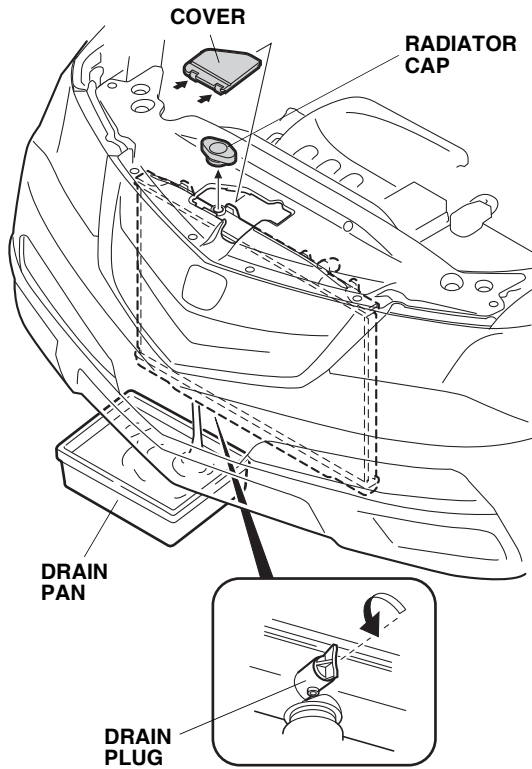

4. Remove the bulkhead cover (eight clips).

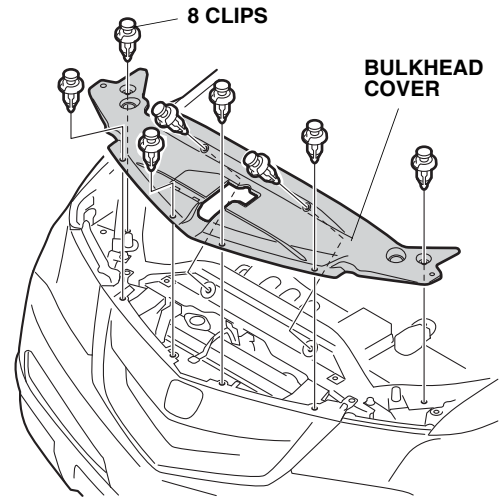

5. Remove the eleven clips, four bolts, and two self-tapping screws that secure the front bumper.

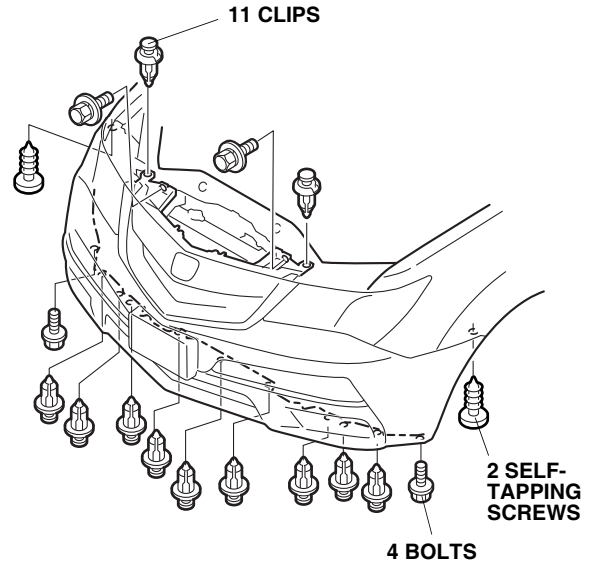

6. With the help of an assistant, unplug the four connectors and remove the front bumper. Set the front bumper on a blanket to prevent damage.

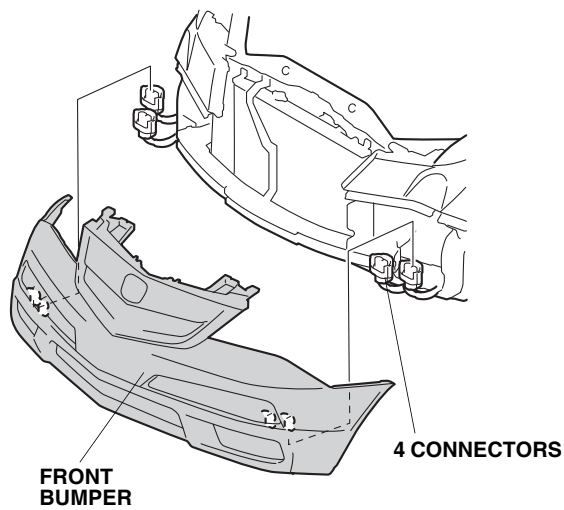

7. Remove the engine cover (two turn clips).

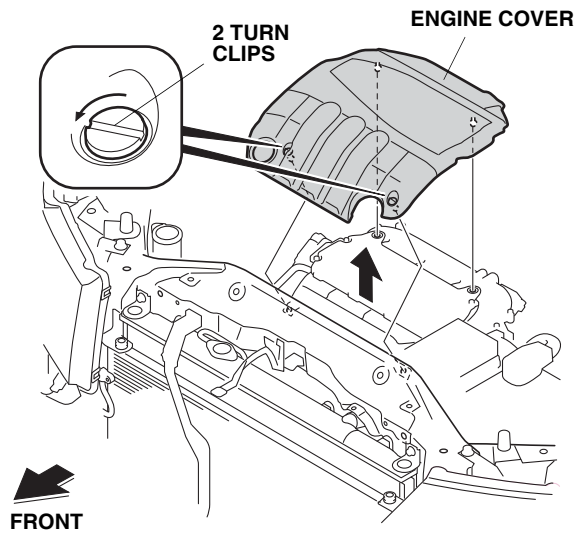

8. Disconnect the negative (-) cable from the battery. Open the positive cable cover, and disconnect the positive (+) cable from the battery. Loosen the two battery holder nuts, and remove the battery holder.

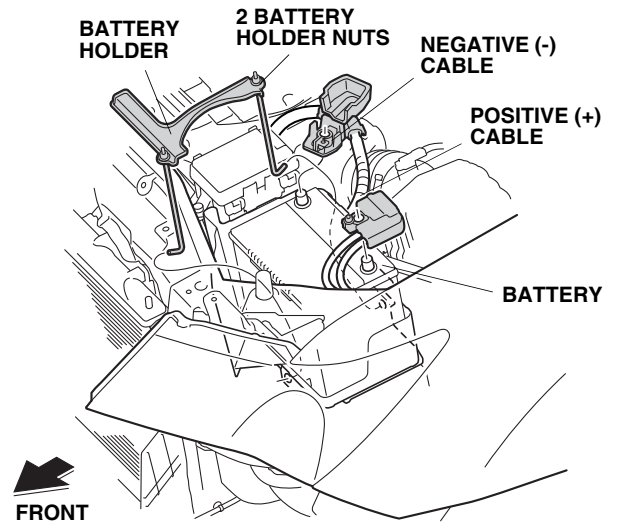

9. Remove the battery and the battery box.

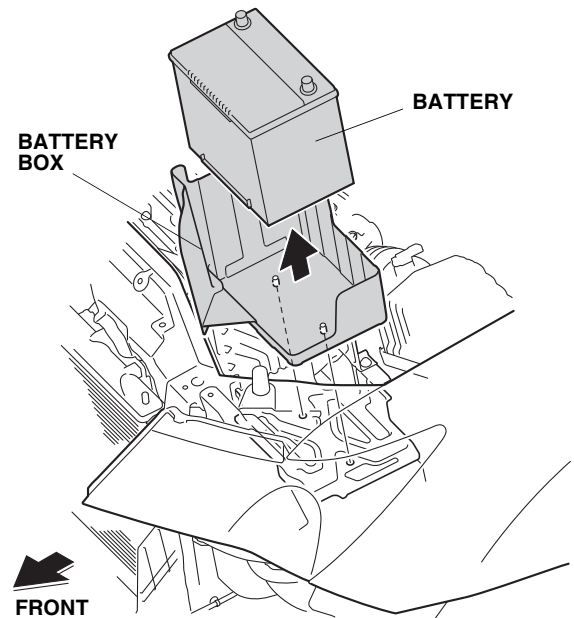

- Unplug the hood latch switch connector, then remove the connector clip from the body.

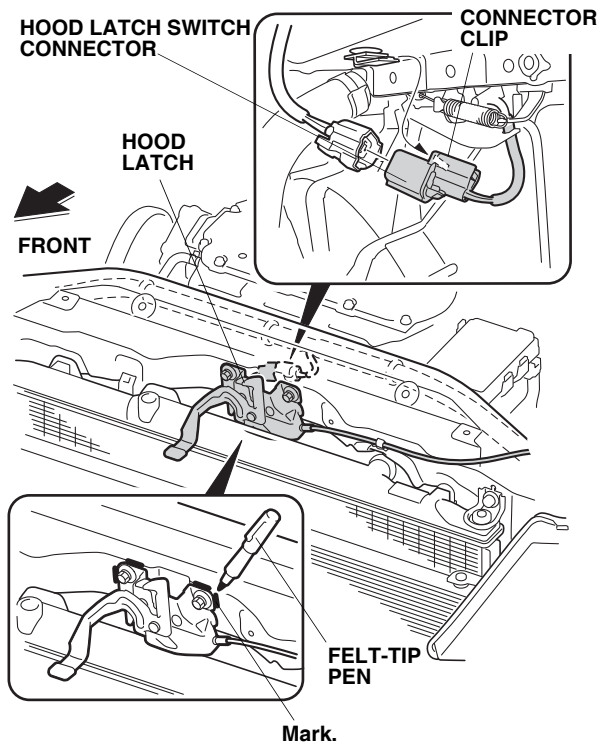

- Using a felt-tip pen, mark around the hood latch for reinstallation.
- Remove the hood latch (three bolts).

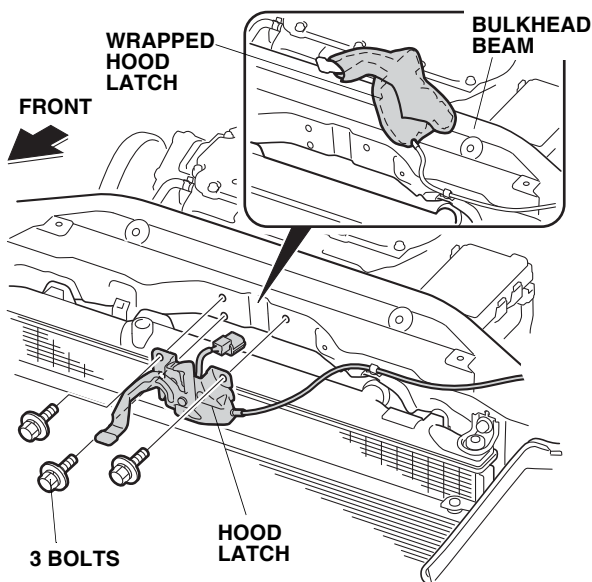

- Wrap the hood latch in a shop towel, then place the hood latch on the bulkhead beam.

- Remove the two upper washer bolts from the radiator.

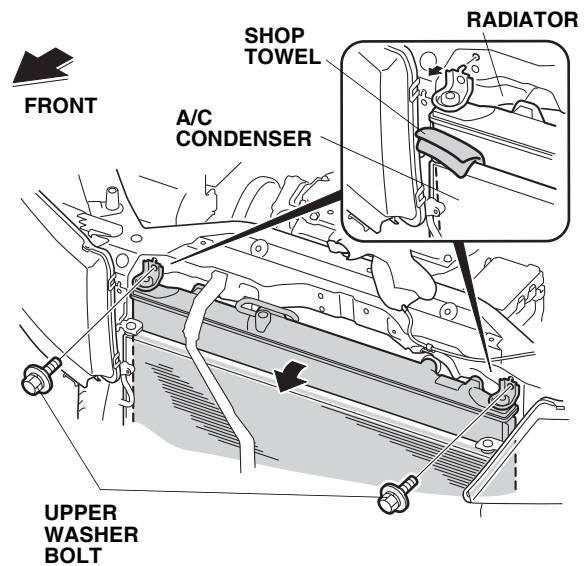

- Place a shop towel between the radiator and the A/C condenser.
- Remove the two A/C condenser washer bolts. Carefully pull the radiator/condenser forward.

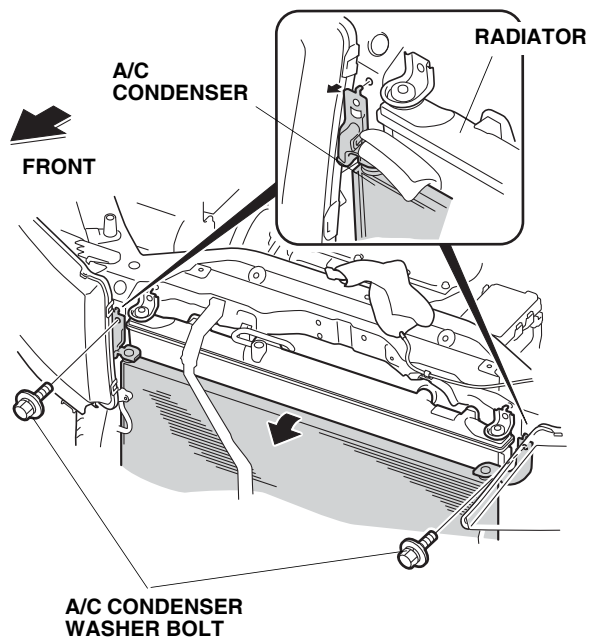

17. Unplug the O2 sensor connector.

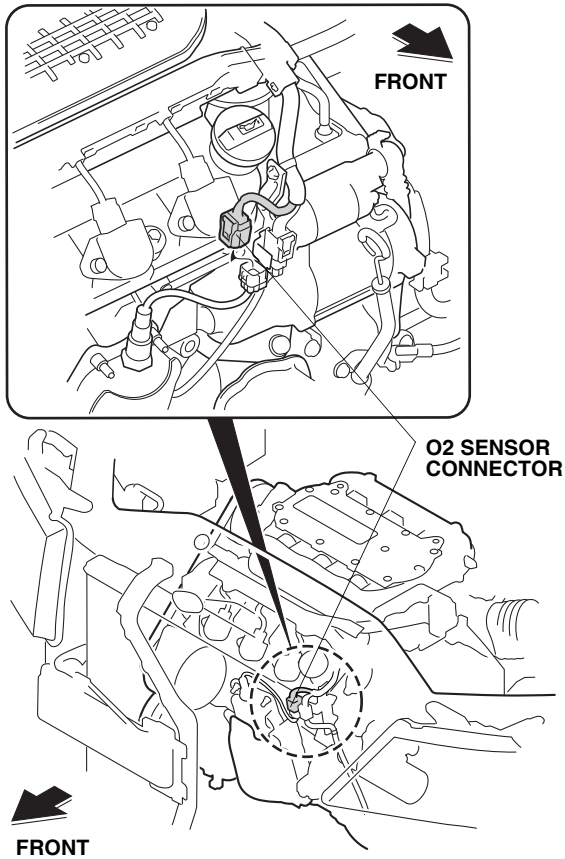

18. Get the heater harness. Using a white marker and a tape measure, mark the heater harness at the measurements shown.

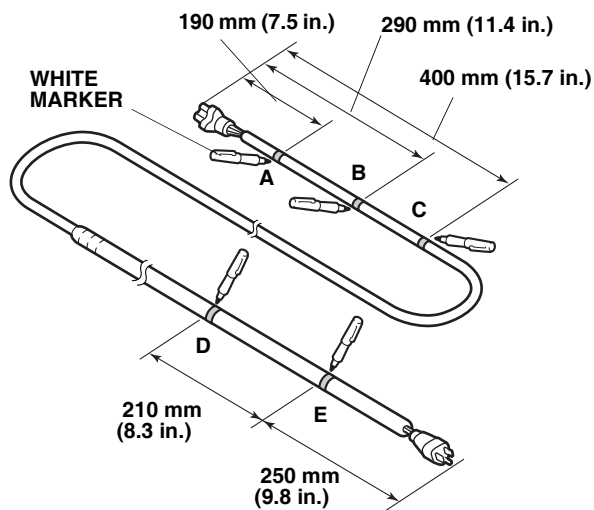

19. Locate and remove the engine block drain bolt and washer. Coolant remaining in the engine jackets may flow out of the bolt hole when the bolt is removed.

NOTE: Retain the bolt in case the block heater is removed. (A new washer should be used when the bolt is reinstalled.)

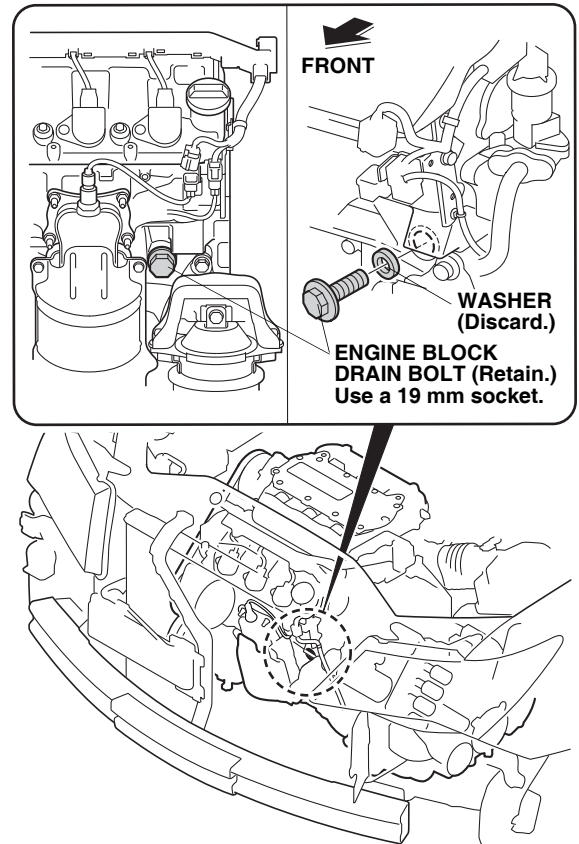

20. Install the engine block heater with aluminum washer into the engine block using a 24 mm socket and a torque wrench. Torque the engine block heater to 60 N·m (44 lbf-ft).

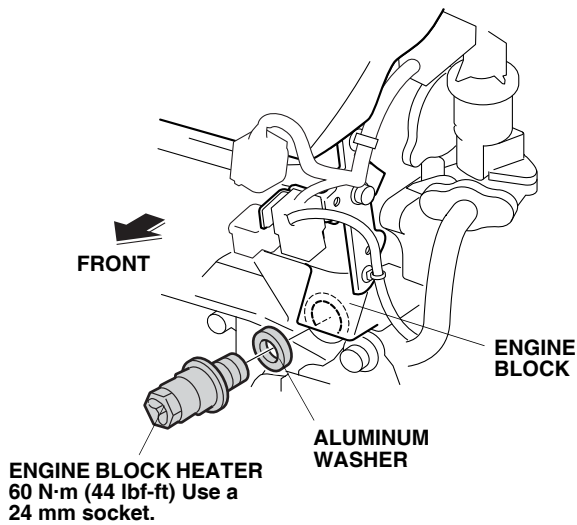

21. Plug the connector end of the heater harness into the engine block heater.

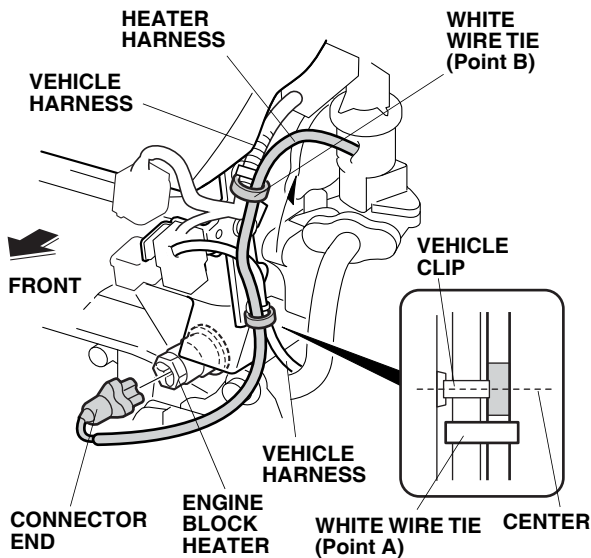

22. Route the heater harness as shown and secure the heater harness using one white wire tie (point A) to the vehicle harness. Secure another white wire tie (point B) to the vehicle harness.

23. Route the heater harness along the fan shroud, and secure it to the fan shroud ribs with four black wire ties. Note that the last fan shroud rib is point C.

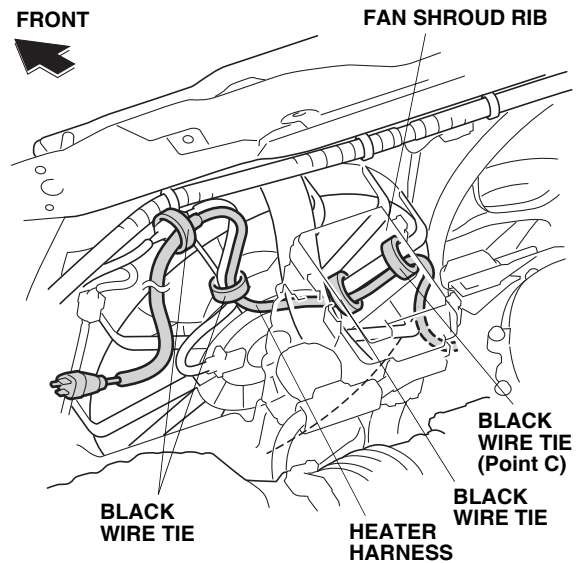

24. Continue routing the heater harness through the engine compartment, and loosely secure it to the vehicle harness with two black wire ties.

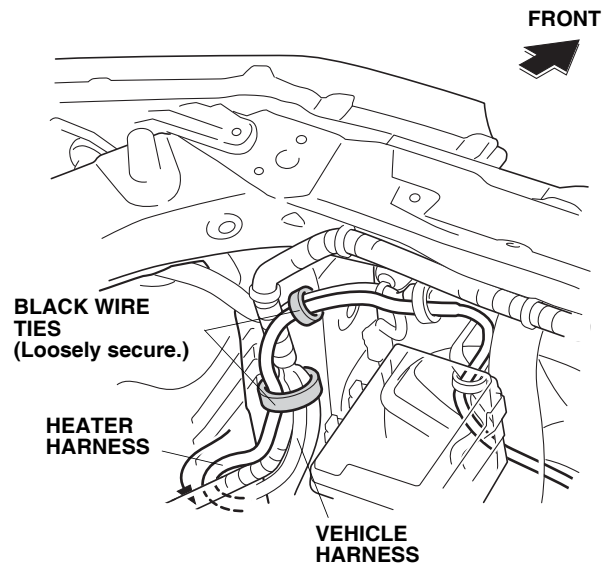



25. Route the heater harness through the opening in the front bulkhead.

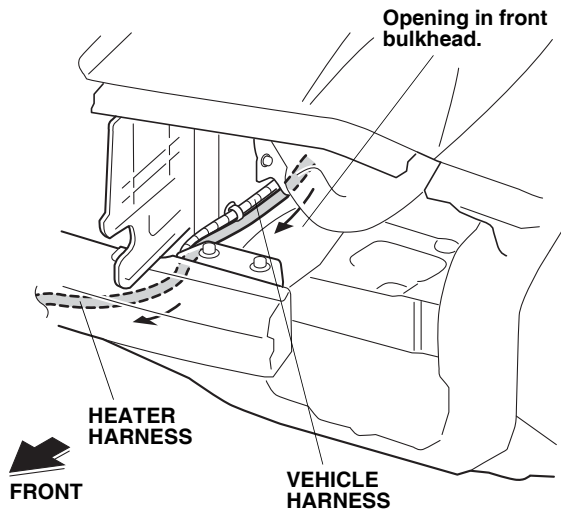

26. Route the heater harness along the bumper beam, and secure it to the vehicle harness using one black wire tie (point D).

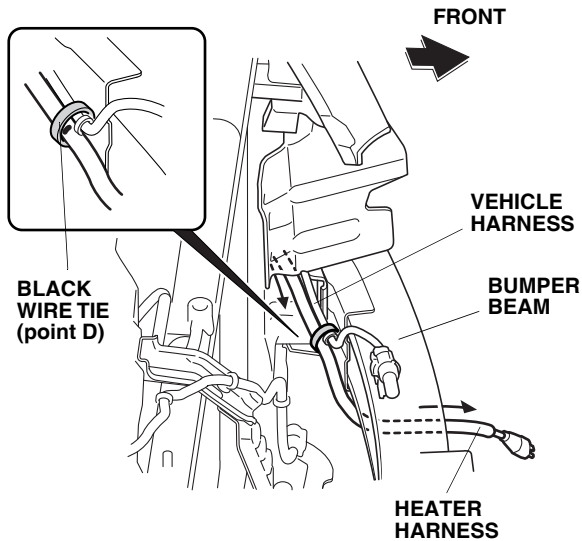

27. Secure the heater harness to the vehicle harness with one black wire tie.

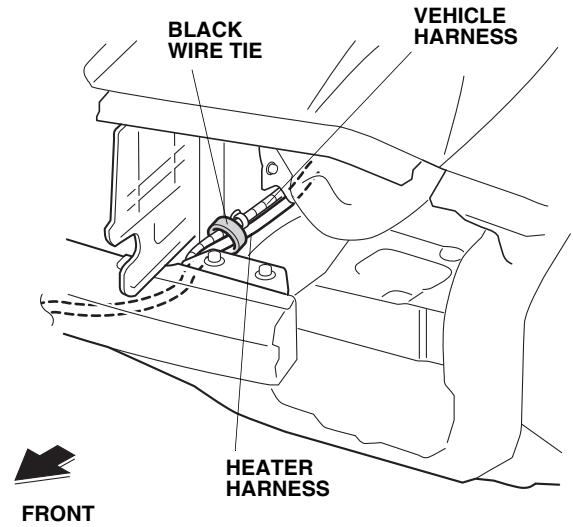

28. Bundle up the excess heater harness, and secure it to the vehicle harness with one black wire tie.

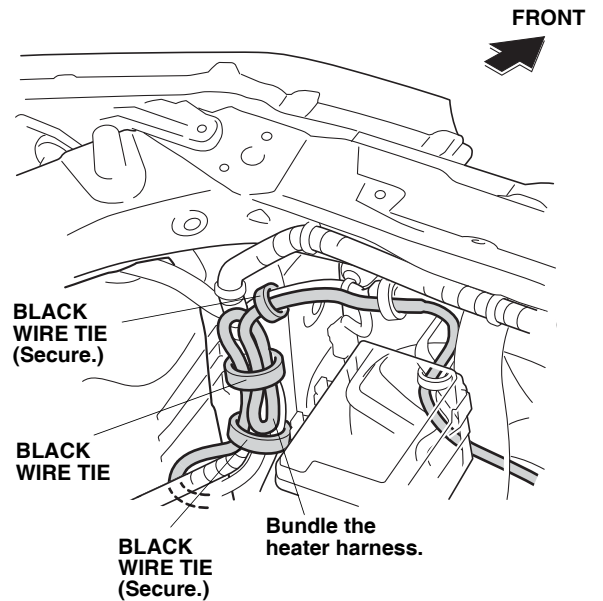

29. Tighten the two black wire ties (loosely installed in step 24).

30. With the help of an assistant, reinstall the front bumper.

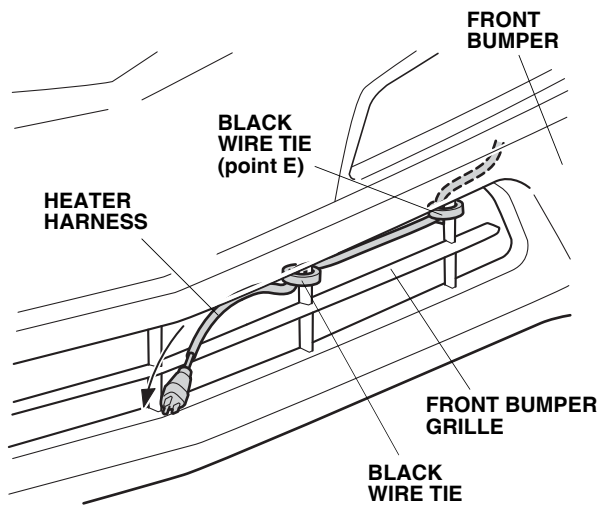

31. Route the heater harness inside the front bumper and secure it to the front bumper grille with two black wire ties.
32. Attach the protective cap to the front bumper grille, and plug the heater harness connector into the protective cap.

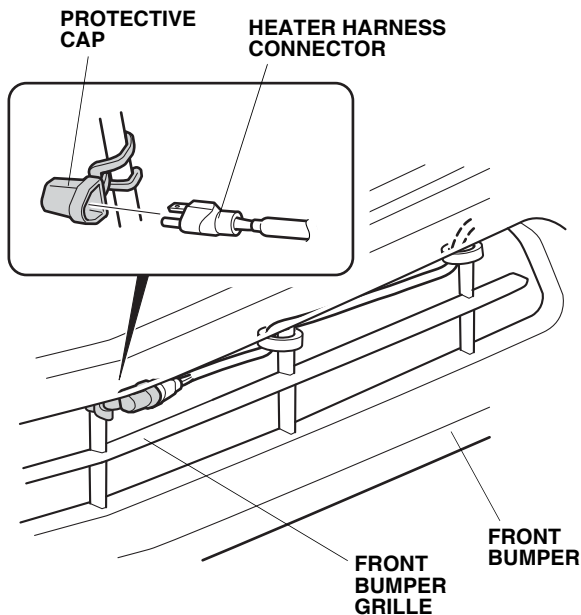

33. Reinstall all removed parts except for the radiator cap and cover.
34. Reinstall the radiator drain plug.
35. Fill the system with the recommended coolant. Follow the instructions described in the service manual to fill and bleed the cooling system.
36. Check the coolant reservoir for correct level and check the cooling system for signs of leakage. Repair as necessary.
37. Reinstall the radiator cap and cover.
38. Check that the heater harness is routed properly and all connectors are plugged in.
39. Put the engine block drain bolt (removed in step 19) in the glove box.
40. Reconnect the negative (-) cable and positive (+) cable to the battery.
41. Enter the radio anti-theft code, and reset the radio station presets.
42. Reset the clock.