



INSTALLATION INSTRUCTIONS

Accessory
ALL-SEASON MATS
P/N 08P13-SZN-200

Application
2010 ZDX

Publications No.
BII 42754
Issue Date
DEC 2009

PARTS LIST

Left front all-season mat

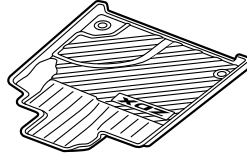

Right front all-season mat

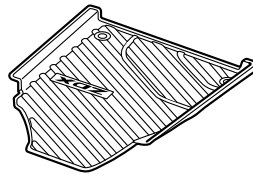

Rear all-season mat

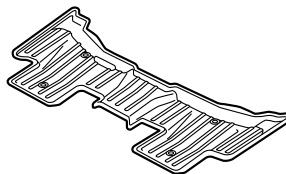
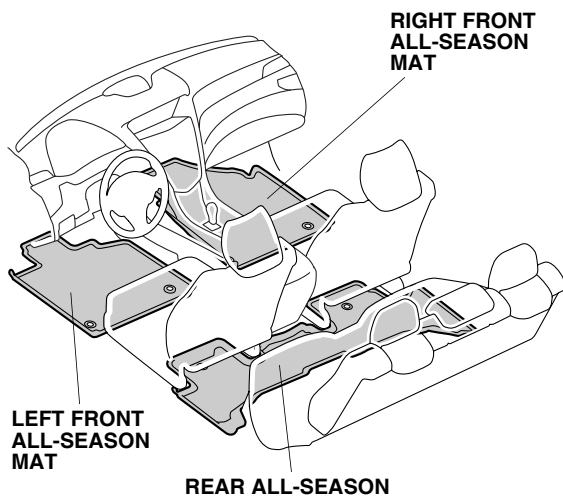

Illustration of the All-Season Mats on the Vehicle



INSTALLATION

NOTE:

- Connect the mats to the holders to prevent the mats from sliding forward and possibly interfering with the pedals.
- When replacing the all-season mats, use all-season mats that are compatible with the holders.
- Do not place additional mats on top of the all-season mats. The additional mats may slide forward and possibly interfere with the pedals.
- Make sure to reanchor the mats after removing them.
- Identify each mat by the mark on the back. The mat for the right side of the vehicle is marked with "R" or "Passenger's side." The mat for the left side of the vehicle is marked "L" or "Driver's side."

1. Remove the existing floor mats.
2. Position the left front all-season mat by placing the two grommets over the two knobs on the holders.

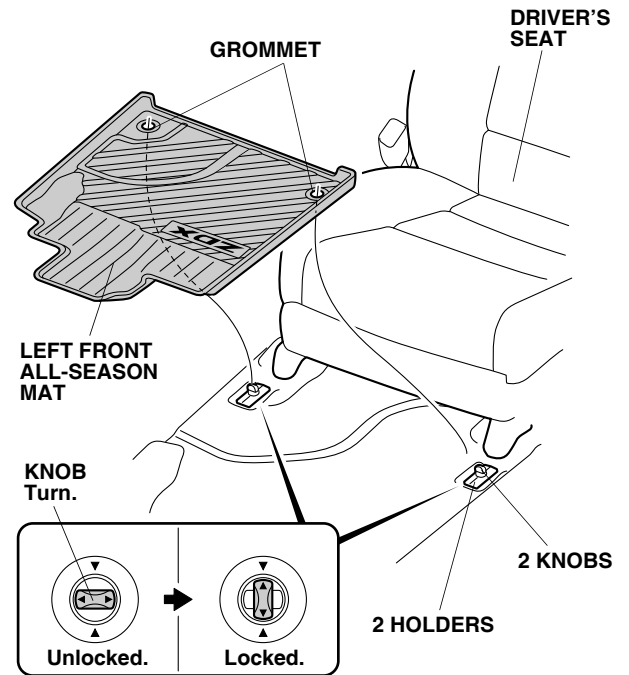

3. Turn the knob on each holder to lock the left front all-season mat in place.

4. Position the right front all-season mat by placing the two grommets over the two knobs on the holders.

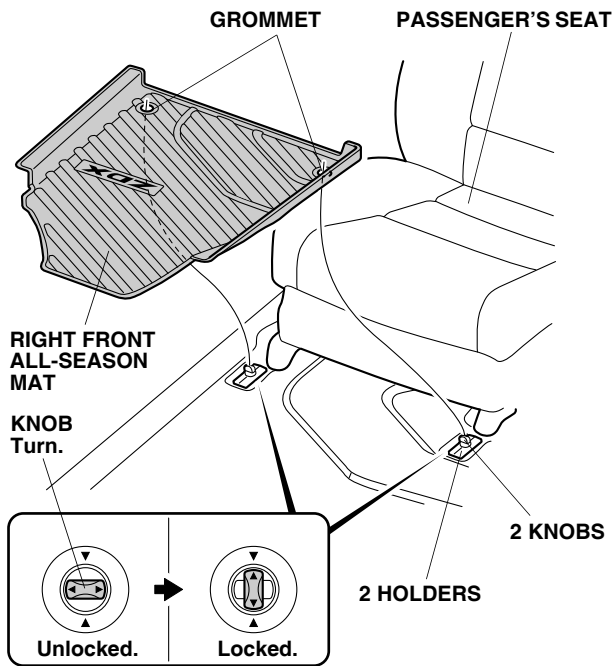

5. Turn the knob on each holder to lock the right front all-season mat in place.

6. Position the rear all-season mat by placing the four grommets over the four knobs on the holders.

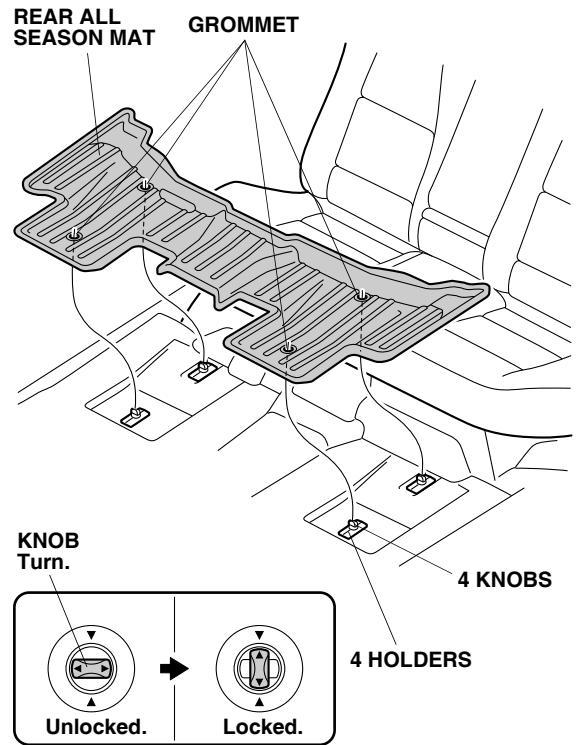

7. Turn the knob on each holder to lock the rear all-season mat in place.