



# INSTALLATION INSTRUCTIONS

Accessory  
**REMOTE CONTROL ENGINE STARTER**

Application  
**2010 TSX (V6)**

Publications No.  
**BII 42923**  
Issue Date  
**OCT 2009**

## PARTS LIST

### Remote Engine Starter Unit Kit P/N 08E91-TK4-200A

Transmitter

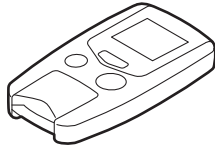

Control unit

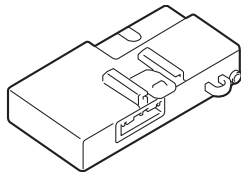

Antenna

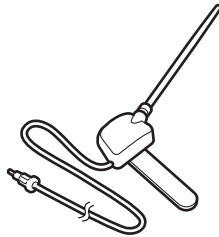

Key ring



Protective tape (black)



Caution label



Fuse label

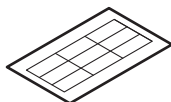

## Accessory User's Information Manual

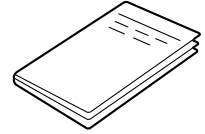

Quick Start Guide

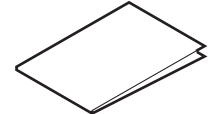

### Remote Control Engine Starter Attachment Kit P/N 08E92-TP1-200

Engine starter harness

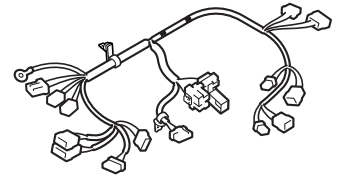

Control unit bracket



Template

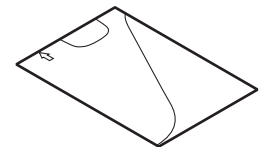

2 Relays

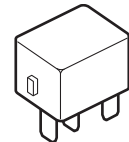

Flange nut



16 Wire ties

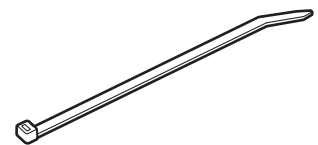

## 6 Urethane tapes

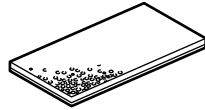

A-Pillar clip



## TOOLS AND SUPPLIES REQUIRED

Phillips screwdriver  
Flat-tip screwdriver  
Small flat-tip screwdriver  
Ratchet  
10 mm Socket  
Combination wrench  
Diagonal cutters  
Isopropyl alcohol  
Shop towel  
Tape measure  
Scale  
Scissors  
Rubber mallet  
HDS (Honda Diagnostic System)  
Masking tape  
2 Pairs of needle nose pliers  
Plastic Trim Tool  
T/N SILTRIMTL10

### *Illustration of the Engine Starter Installed on the Vehicle*

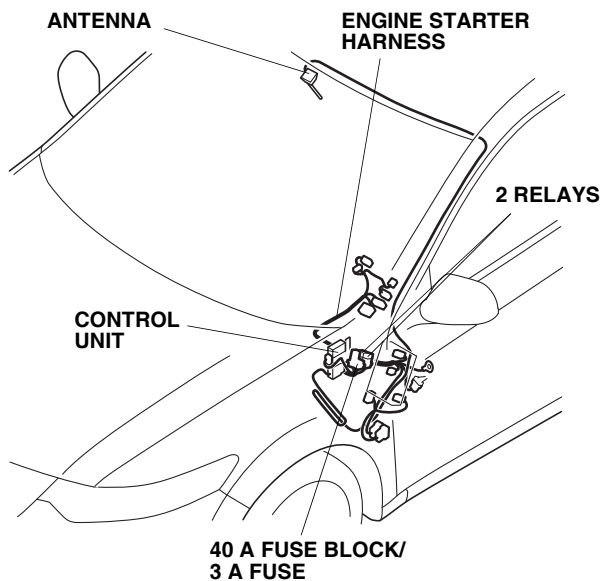

## INSTALLATION

**Client Information:** The information in this installation instruction is intended for use only by skilled technicians who have the proper tools, equipment, and training to correctly and safely add equipment to your vehicle. These procedures should not be attempted by “do-it-yourselfers.”

**NOTE:** This antenna should only be installed if the ambient air temperature 15°C (60°F) or above.

1. Make sure you have the anti-theft code for the radio, then write down the radio station presets.
2. Remove the left engine compartment cover (one clip, three pins, and one tab).

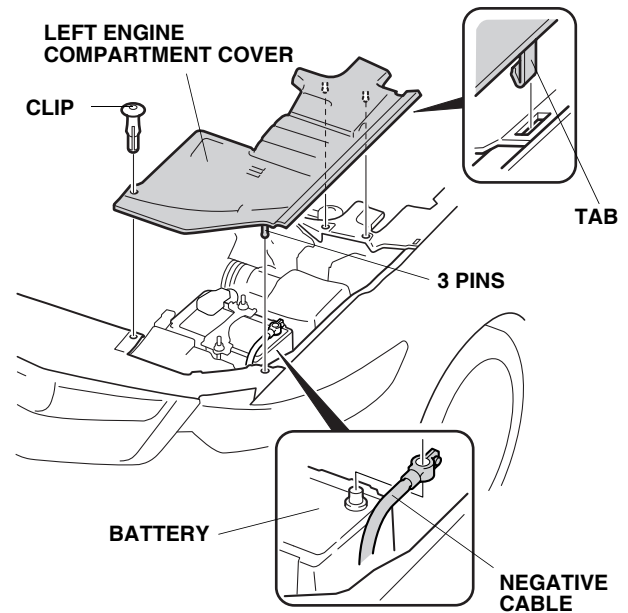

3. Disconnect the negative cable from the battery.

## Setting the Control Unit

4. Touch the metal part of the screwdriver to any metal part of the vehicle to discharge any static electricity.

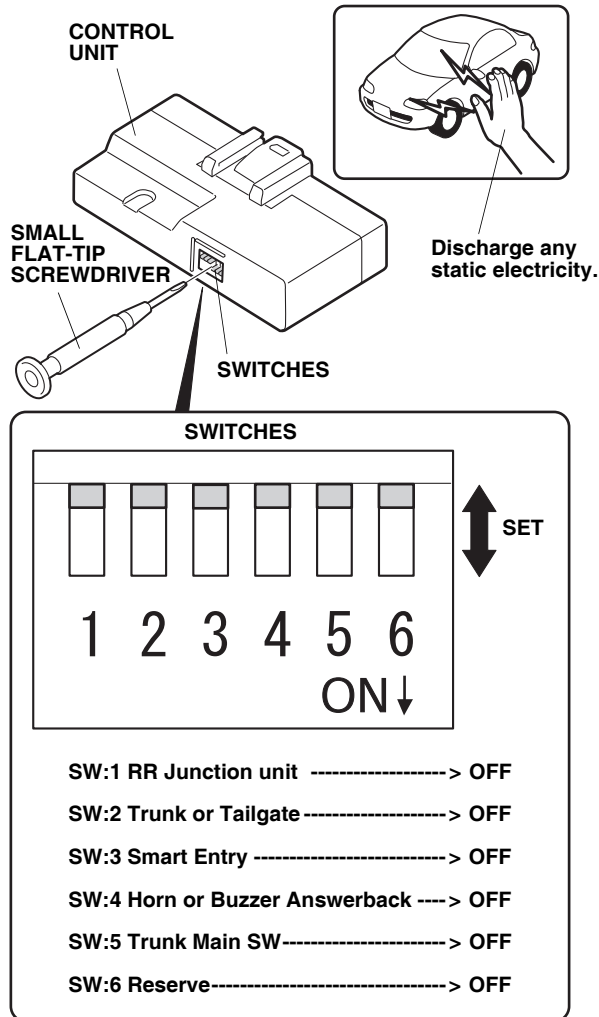

5. Check a location of the switches on the control unit.

### NOTE:

- The switches must be selected before the control unit is plugged in.
- If the switch setting is not correct, the remote engine starter will not operate correctly.
- If you change the switch settings with the unit connected, you must disconnect the unit then reconnect it before the settings change.

6. Using a small flat-tip screwdriver, adjust the switches on the control unit as shown.

7. Using isopropyl alcohol on a shop towel, clean the area where the protective tape will attach. Attach the protective tape to the control unit over the switches.

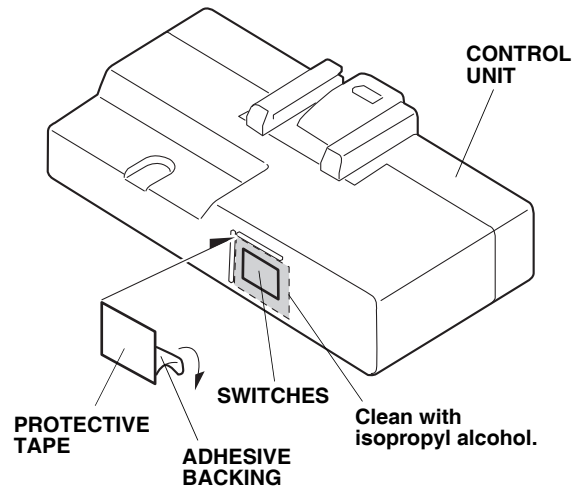

8. Remove the driver's dashboard lower cover (one screw, twelve clips, and unplug the vehicle connector).

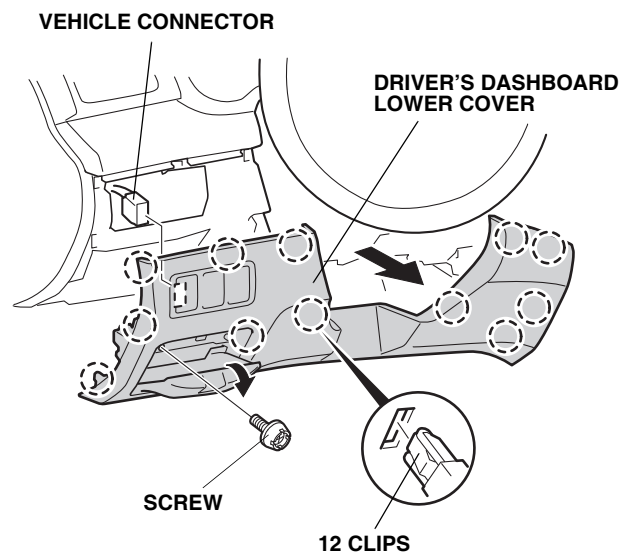

9. Remove the driver's dashboard under cover (two clips and one pin, and unplug the vehicle connector).

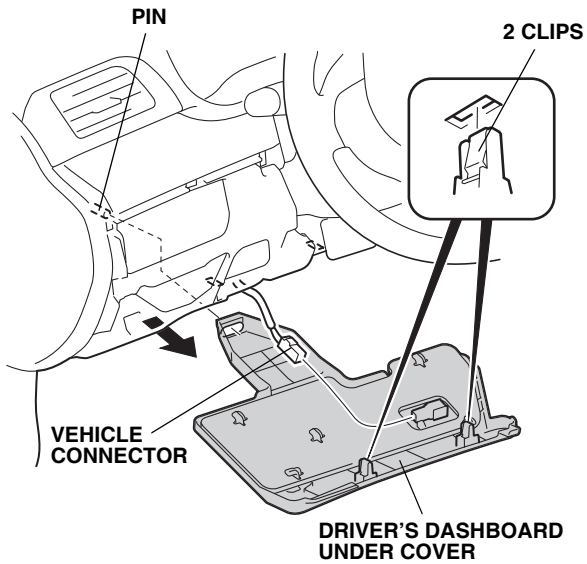

10. Remove the left front door sill trim (four clips and four retaining tabs).

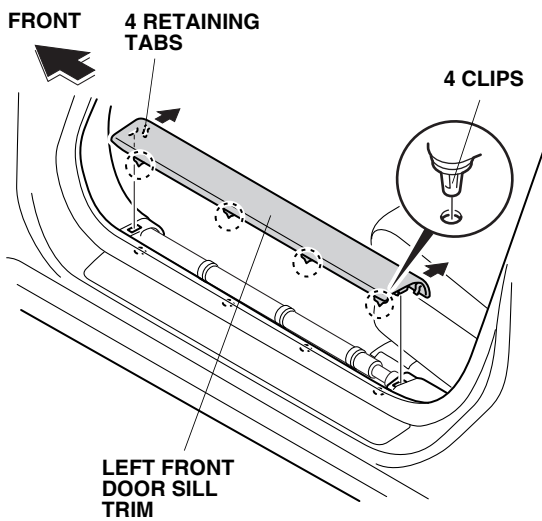

11. Pull away the weatherstrip in the area shown, and remove the left kick panel (two clips).

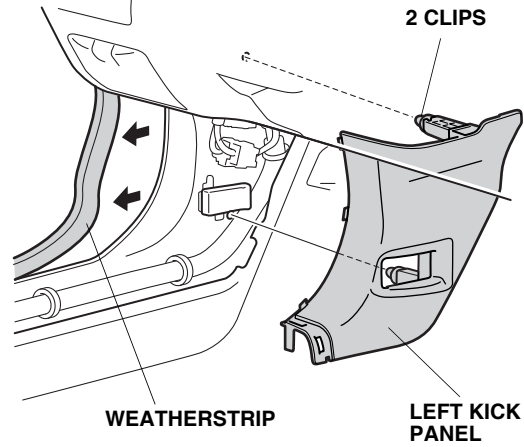

12. Remove the left dashboard side cover (six clips).

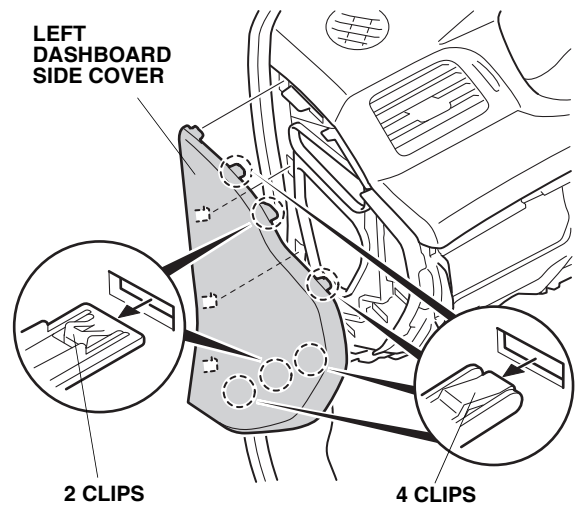

- Lower the tilt lever and pull the steering wheel out.

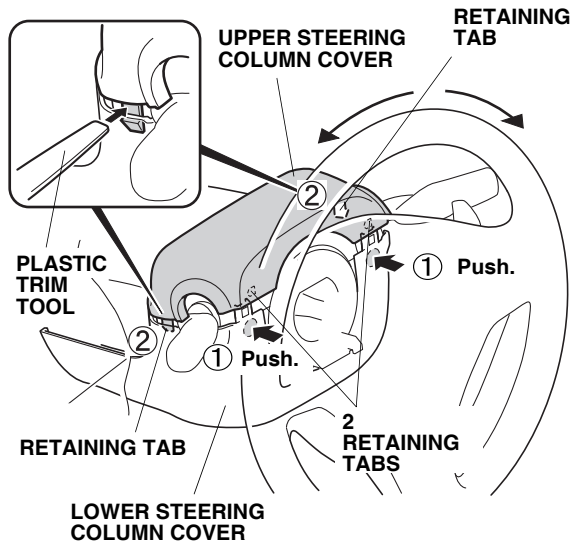

- Remove the upper steering column cover:
  - Turn the steering wheel clockwise to access the tab release (point ①) push in on the lower steering column cover in the areas shown to release both the tab, turn the steering wheel counterclockwise to release the tab on the other side.
  - Insert a plastic trim tool, insert between the upper and lower steering column covers to release the retaining tabs ② as shown.
  - Insert the plastic trim tool between the upper cover hood and lower steering column cover to release the two hood hooks as shown.

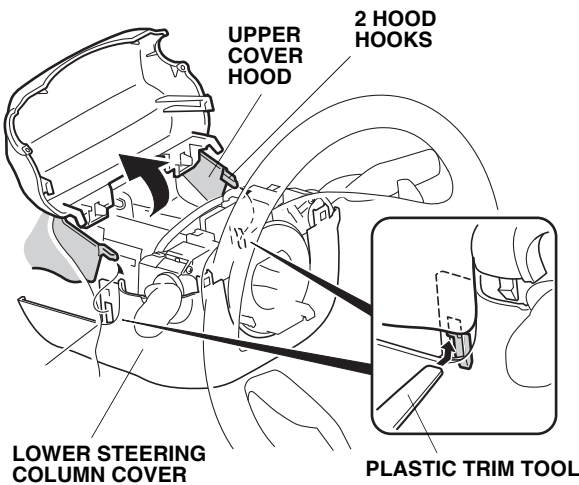

- Remove the upper steering column cover from the upper cover hood (two clips)

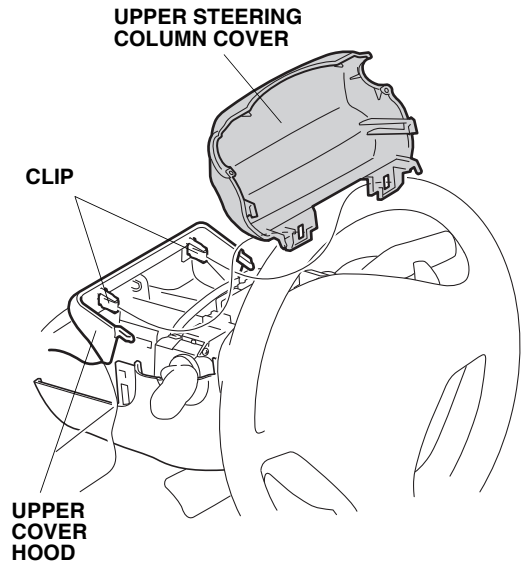

- Remove the lower steering column cover (one screw and two self-tapping screws).

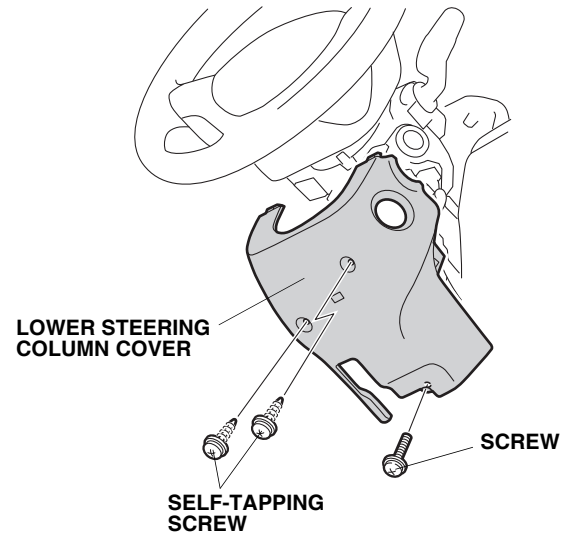

16. Remove the roof console:
- Using a plastic trim tool, pry out and remove the left and right lens (four retaining tabs each).

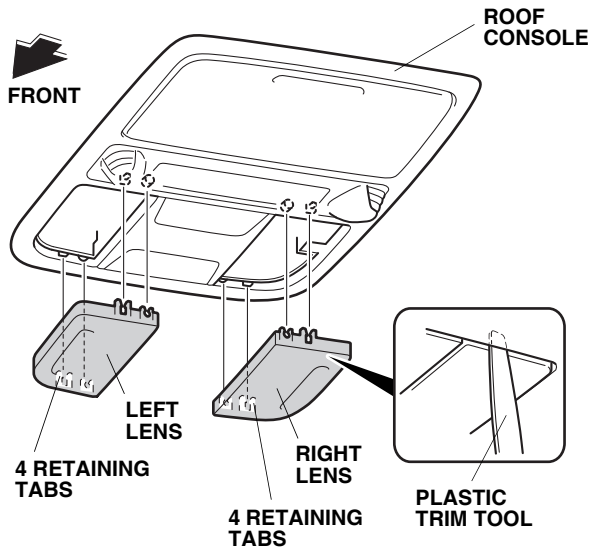

- Open the sunglasses holder, and remove the four screws.
- Unplug the vehicle connectors to remove the roof console.

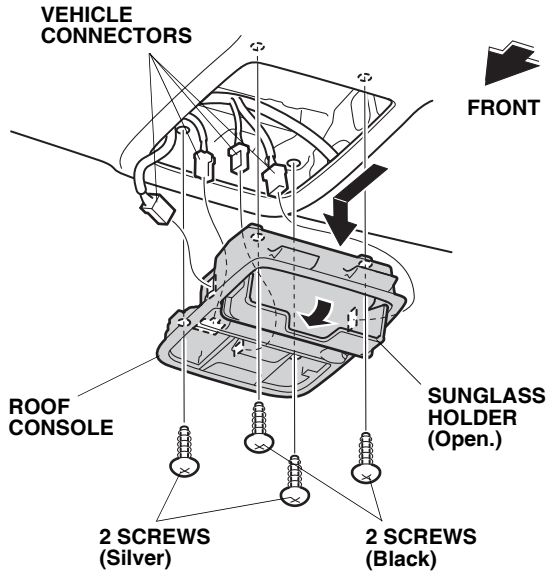

17. Turn the sunvisor holder 90°, and remove the two sunvisor holders.

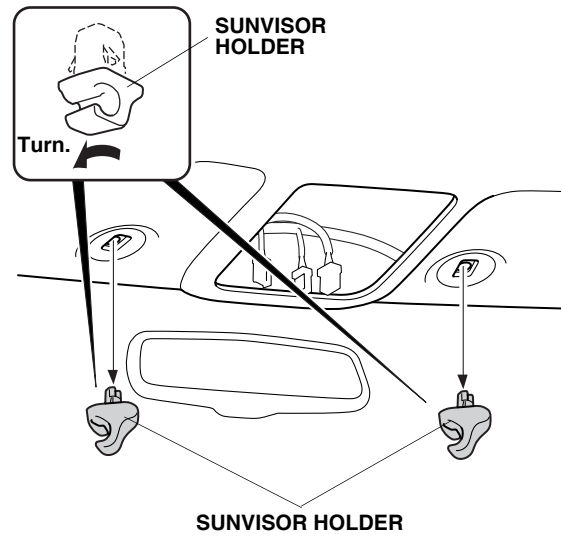

18. Locate the slot in the holder, and insert a flat-tip screwdriver into the slot. Push in and hold the retaining tab.

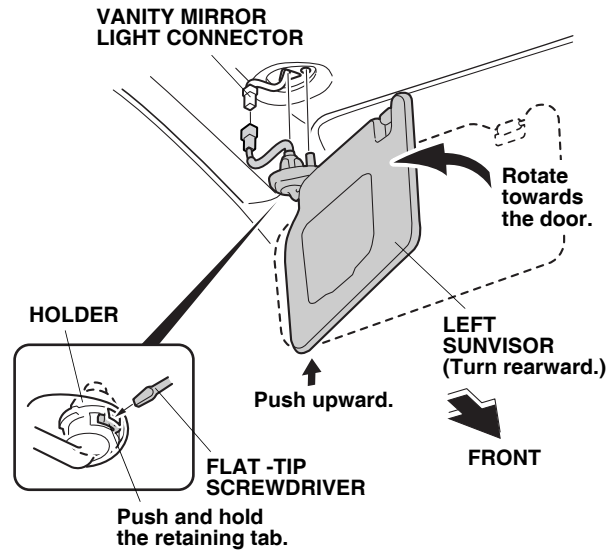

19. While holding the retaining tab, rotate towards the door to remove the left sunvisor. Unplug the vanity mirror light connector. If the retaining tab did not stay pushed in, return the left sunvisor to its original position and repeat the steps 18 and 19.

20. Pull away the weatherstrip from the left front A-pillar trim.

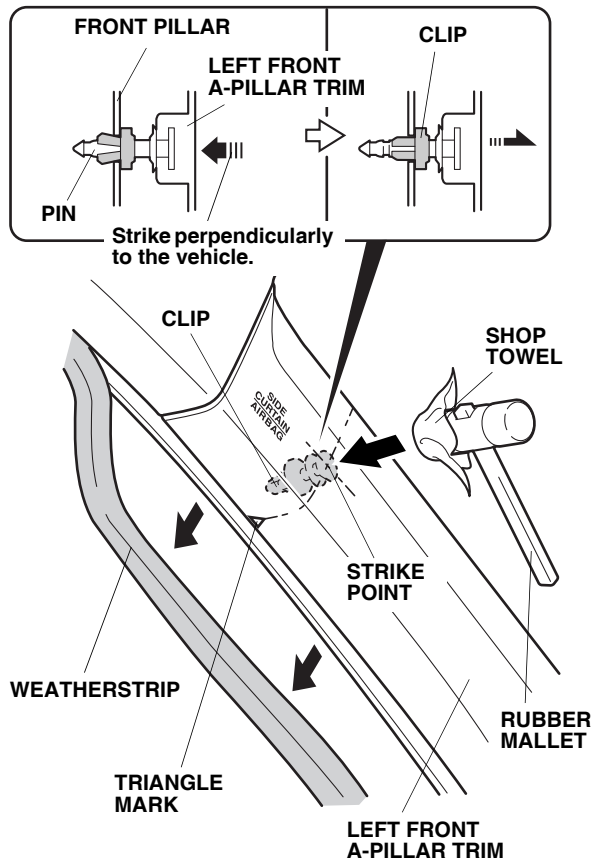

21. Using a rubber mallet and a shop towel, gently tap the left front A-pillar trim at the position shown to release the clip.
22. Remove the left front A-pillar trim (one clip).

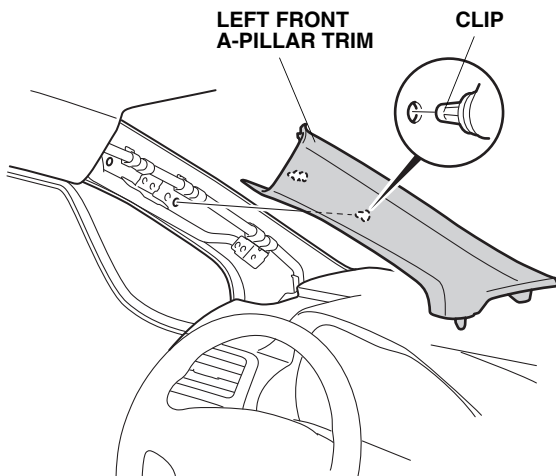

23. Remove and discard the clip from the left front A-pillar trim, and install a new A-pillar clip (supplied) on the left front A-pillar trim.

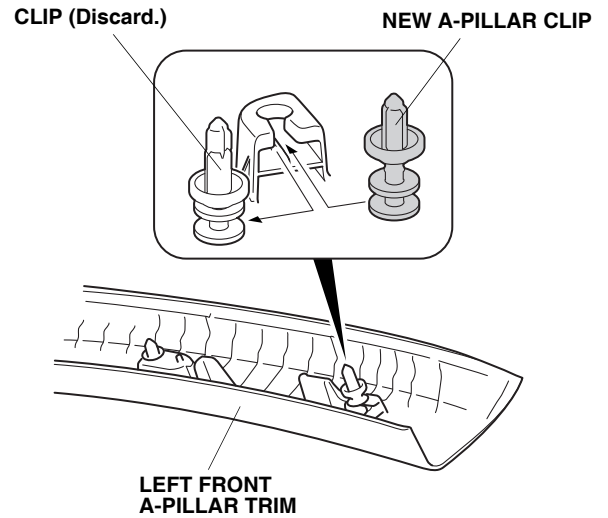

### Routing the Engine Starter Harness

24. Attach the 3A and 40A fuse labels to the engine starter harness fuse block.

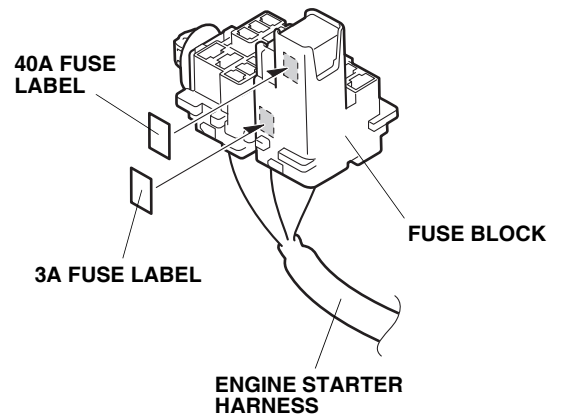

25. Install the two relays on the engine starter harness relay blocks.

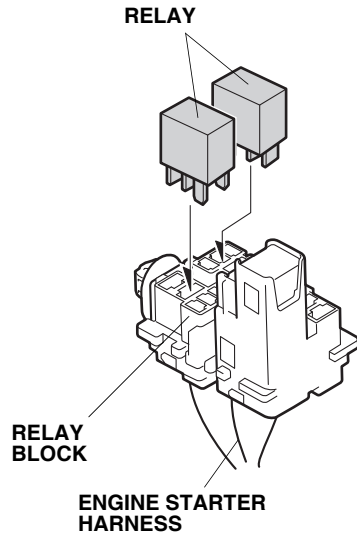

26. Route the 12-pin/8-pin/7-pin connector end of the engine starter harness to the ignition switch.

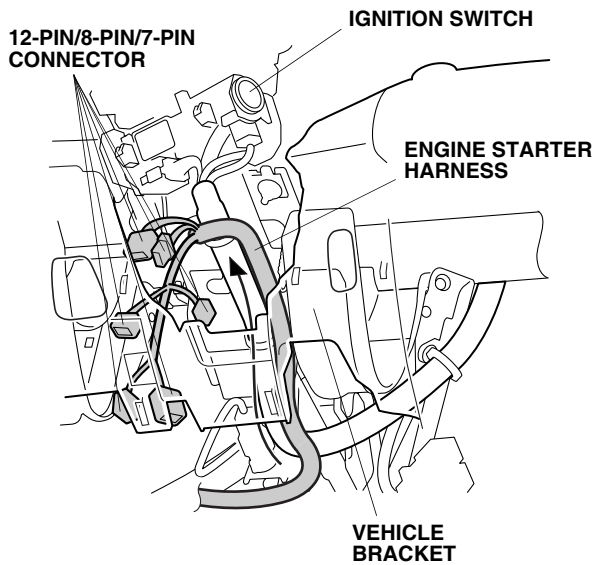

27. Unplug the vehicle 7-pin connector, and plug it into the engine starter harness 7-pin connector. Plug the remaining engine starter harness 7-pin connector into the vehicle 7-pin connector.

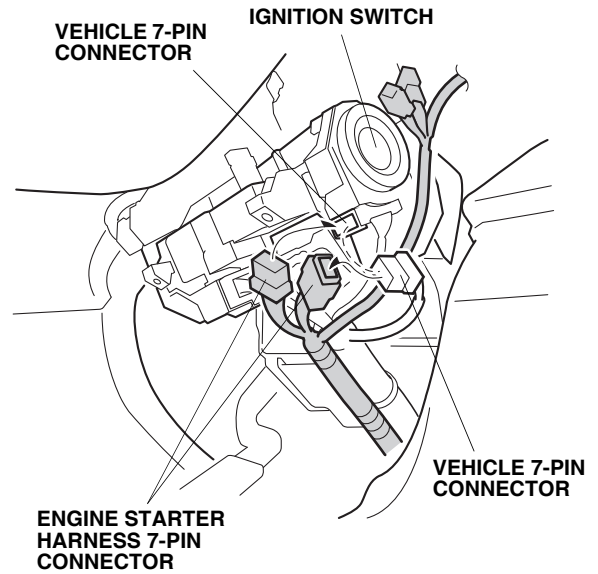

28. Unplug the vehicle 12-pin connector, and plug it into the engine starter harness 12-pin connector. Plug the remaining engine starter harness 12-pin connector into the turn signal switch.

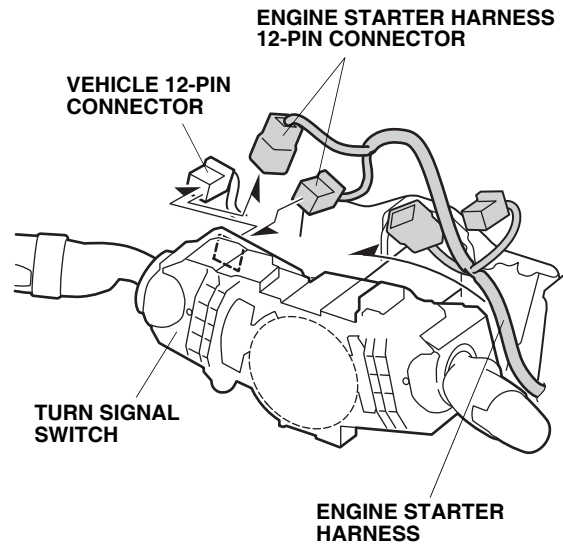



29. Unplug the vehicle 8-pin connector, and plug it into the engine starter harness 8-pin connector. Plug the remaining engine starter harness 8-pin connector into the wiper switch.

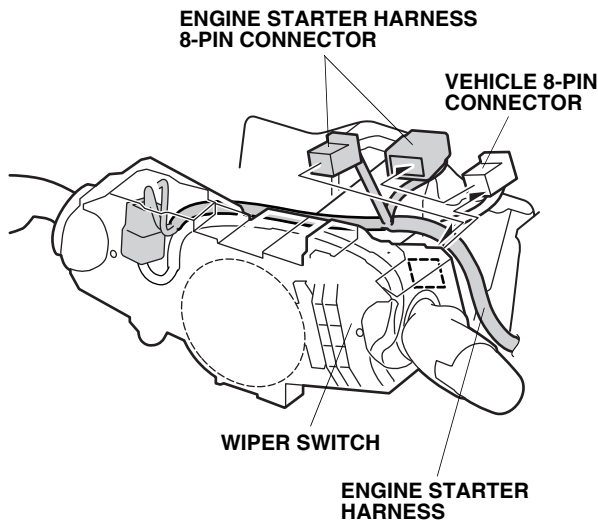

30. Secure the engine starter harness to the vehicle harness using two wire ties. Do not secure it to the SRS harness.

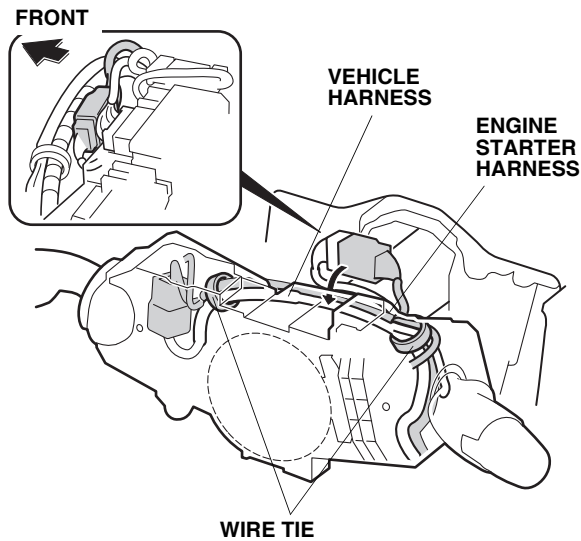

31. Align the white tape on the engine starter harness with vehicle clip as shown, and secure the engine starter harness to the vehicle harness with three wire ties in the areas shown.

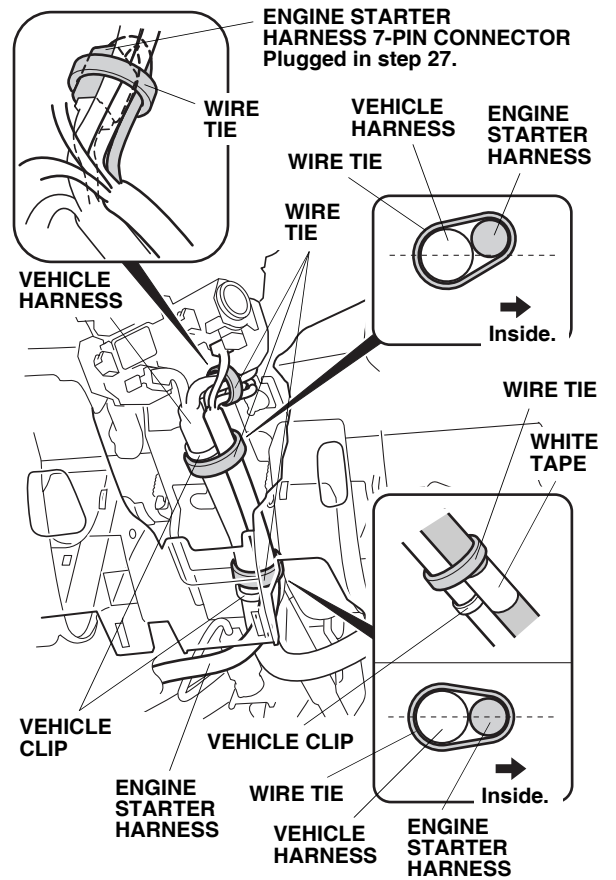

32. Align the white tape on the engine starter harness with the holes in the dashboard behind the tilt lever as shown, and secure the engine starter harness to the dashboard with one wire tie.

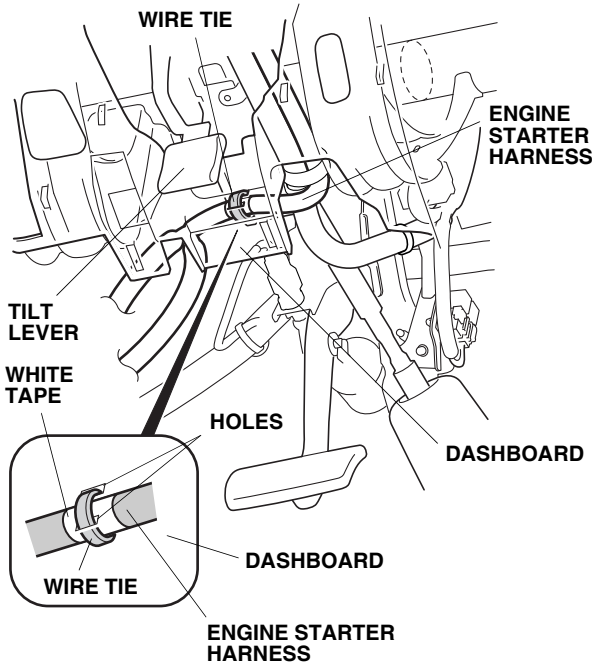

33. Route the engine starter harness through the opening in the vehicle frame in front of the fuse box.

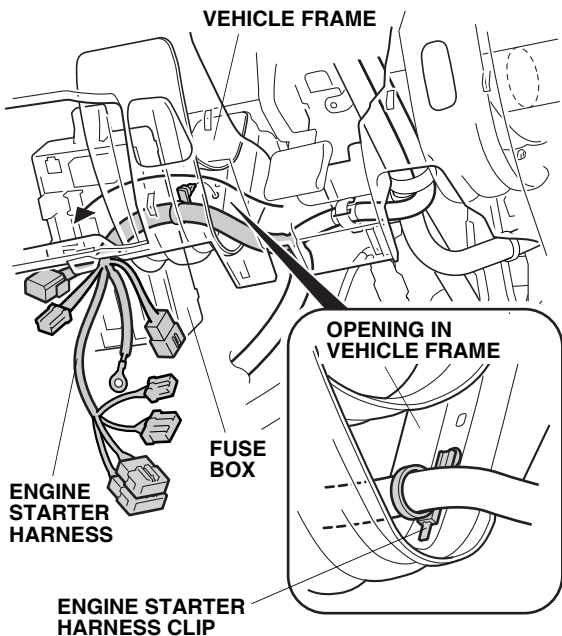

34. Attach the engine starter harness clip to the clip on the vehicle frame as shown.

35. Unplug the vehicle 5-pin connector from the fuse box, and plug the engine starter harness 5-pin connector into the fuse box.

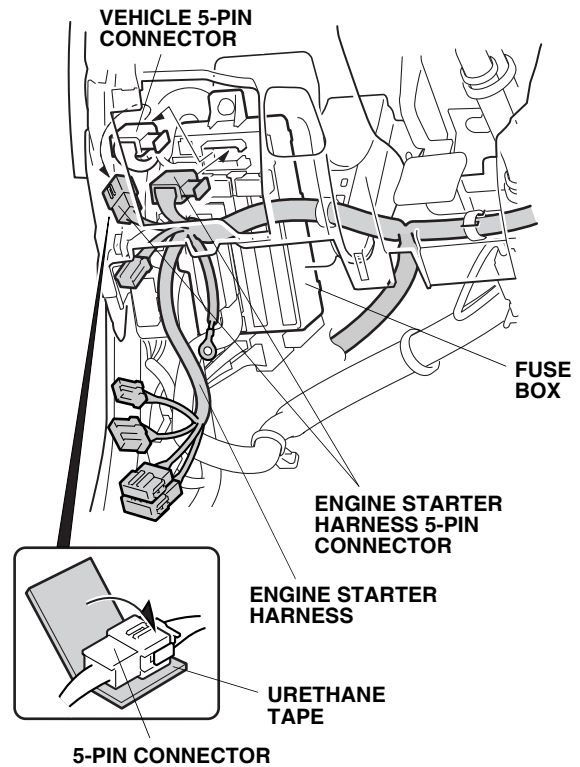
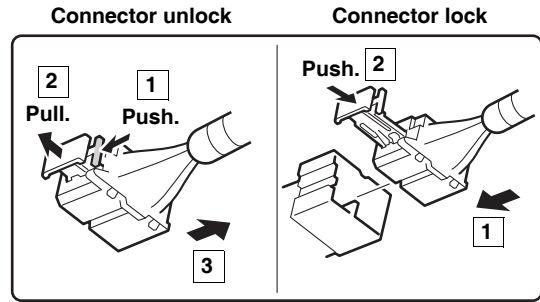

36. Plug the vehicle 5-pin connector into the engine starter harness 5-pin connector.

**NOTE:** Check that the engine starter harness 5-pin connector is plugged to the vehicle connector and locked securely. A loose connector can cause the engine to stall during driving

37. Wrap one urethane tape around the 5-pin connector.

38. Secure the engine starter harness 5-pin connector to the vehicle harness with one wire tie.

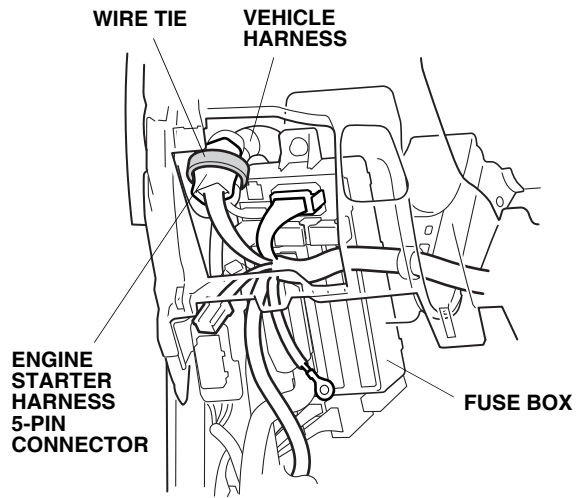

39. Plug the engine starter harness 12-pin connector into the fuse box 12-pin connector.

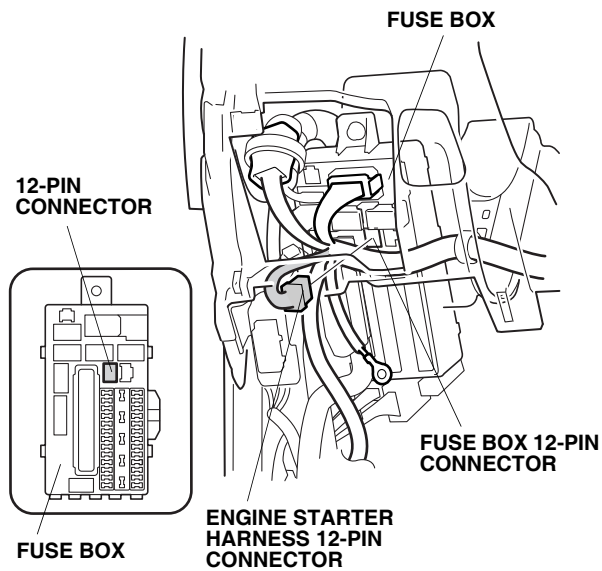

40. Remove the vehicle ground bolt. Attach the engine starter harness ground terminal to the vehicle ground terminal, and reinstall the vehicle ground bolt.

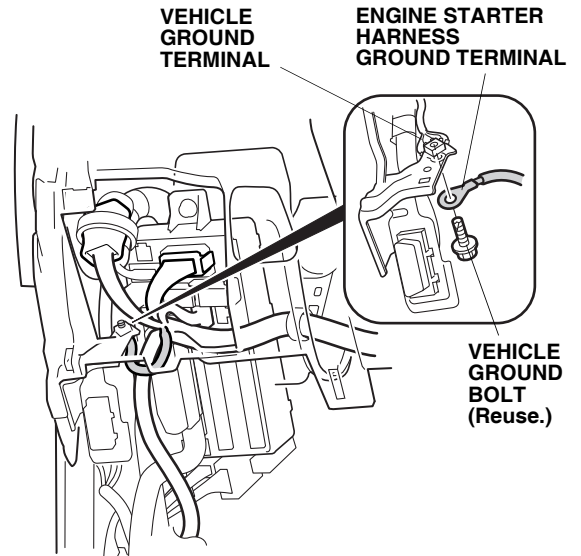

41. Loosely secure the engine starter harness to the vehicle harness with one wire tie.

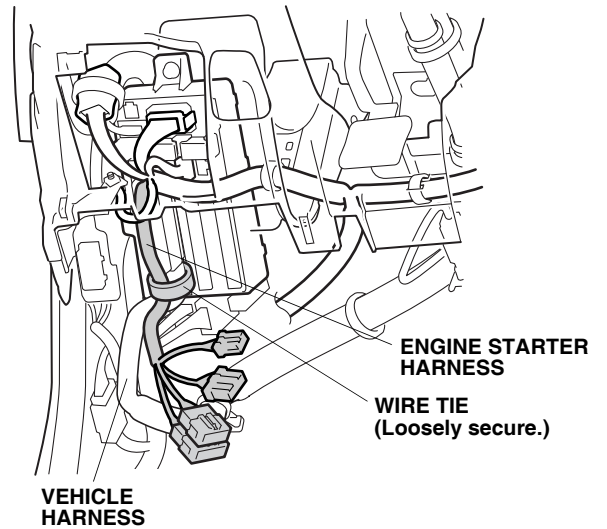

42. Unplug the vehicle 24-pin connector from the fuse box, and plug the engine starter harness 24-pin connector into the fuse box. Plug the remaining engine starter harness 24-pin connector into the vehicle 24-pin connector.

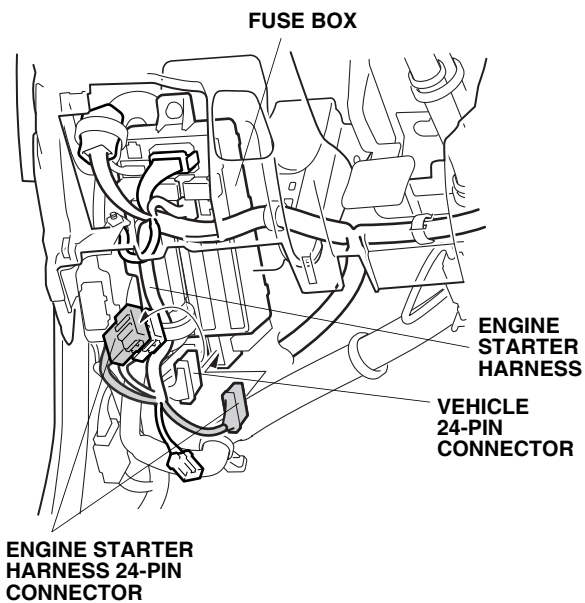

43. Unplug the vehicle 13-pin connector from the fuse box, and plug the engine starter harness 13-pin connector into the fuse box. Plug the remaining engine starter harness 13-pin connector into the vehicle 24-pin connector.

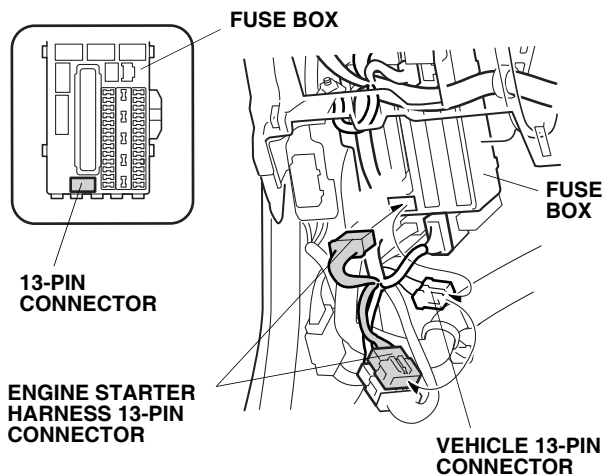

44. Attach the engine starter harness 24-pin connector and 13-pin connector onto the existing 9-pin vehicle connector already attached to the side panel.

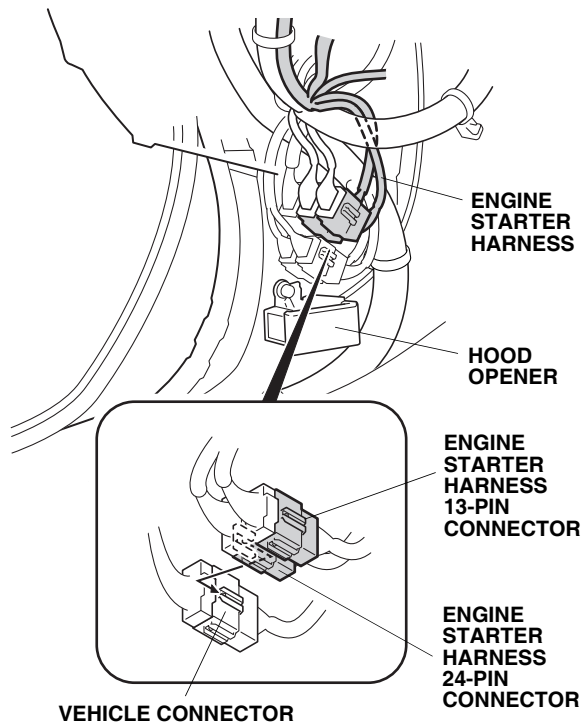

### Installing the Antenna

45. Using scissors, cut out the template.

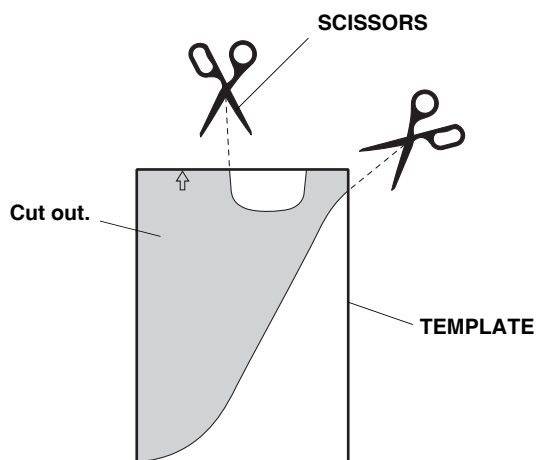



50. Using isopropyl alcohol on a shop towel, clean the windshield where the antenna will attach.

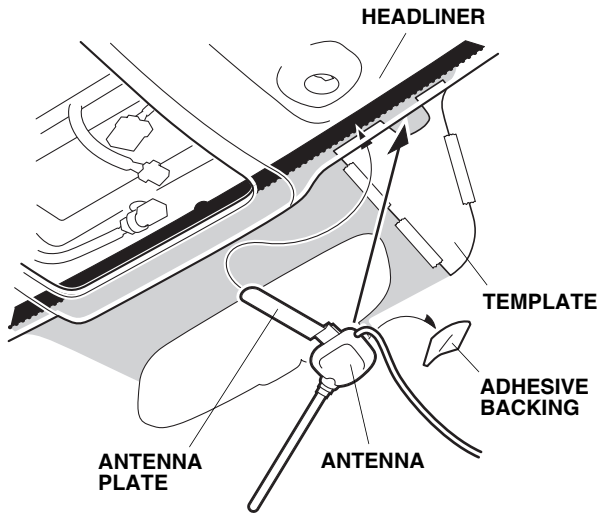

51. Remove the adhesive backing from the antenna. Insert the antenna plate over the headliner, and attach the antenna to the windshield aligning it with the template.
52. Remove the template.
53. Gently pull down the headliner, and tuck the antenna cable under it. Be careful not to crease the headliner.

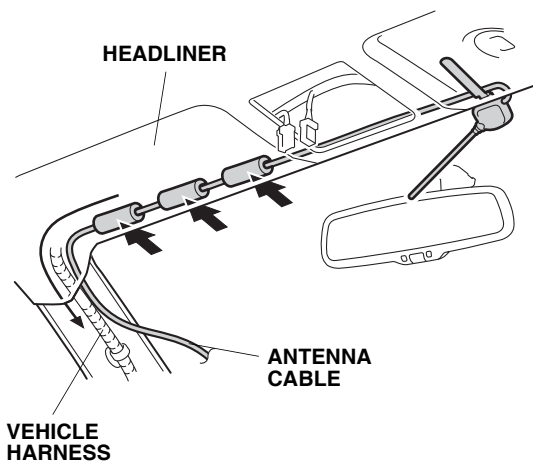

54. Using isopropyl alcohol on a shop towel, clean the roof panel where the urethane tape will attach.

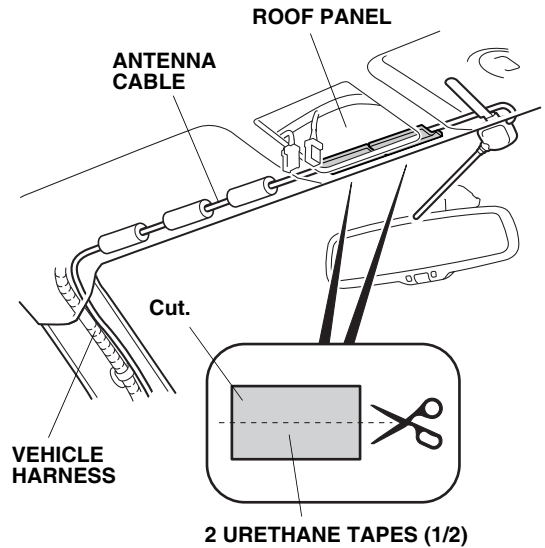

55. Using scissors, cut one urethane tape in half. Secure the antenna cable to the roof panel with the two cut pieces of urethane tape.
56. Pull away the weatherstrip. Route the antenna cable down under the dashboard. Tuck the antenna cable between the left front A-pillar and the dashboard, and reinstall the weatherstrip.

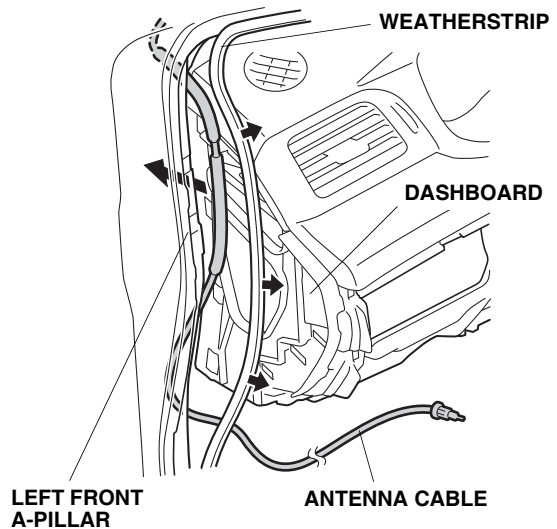

57. Secure the antenna cable to the vehicle harness with four wire ties.
- NOTE: If the vehicle is equipped with the moonroof, do not secure the wire ties to the front drain tube.

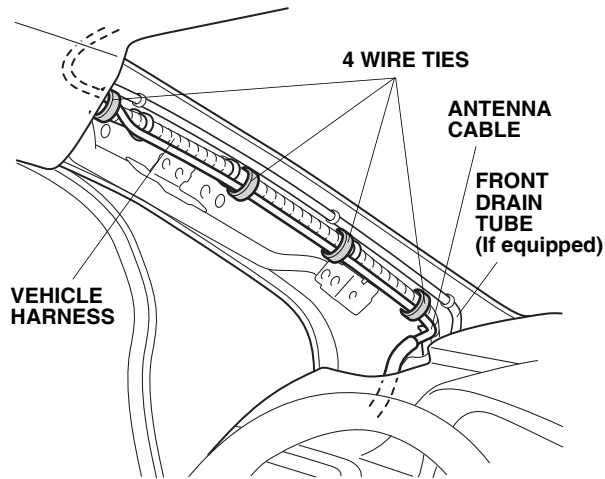

58. Secure the antenna cable with the one wire tie loosely secured to the vehicle harness in step 41.

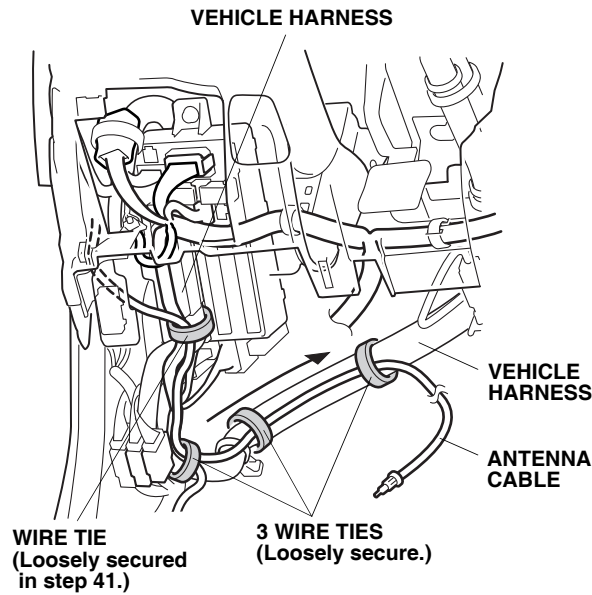

59. Route the antenna cable along the vehicle harness, and loosely secure the antenna cable to the vehicle harness with three wire ties.

## Installing of the Control Unit

60. Install the control unit bracket to the control unit.

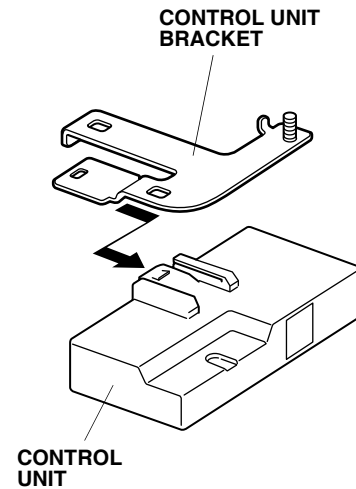

61. Plug the engine starter harness 28-pin connector into the control unit.

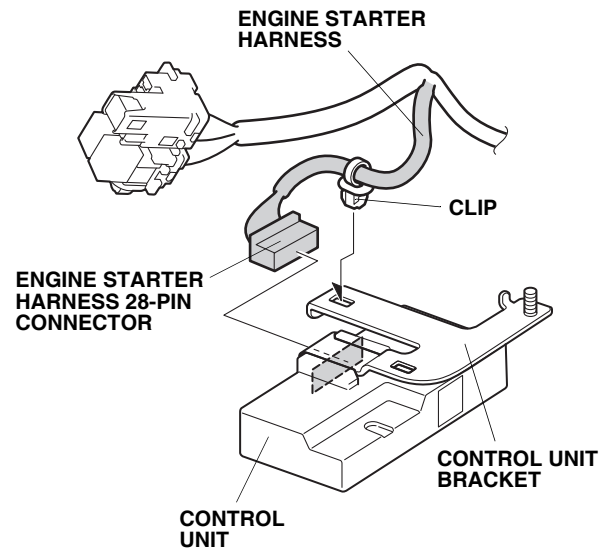

62. Install the clip from the engine starter harness to the control unit bracket.

63. Plug the antenna terminal into the control unit.

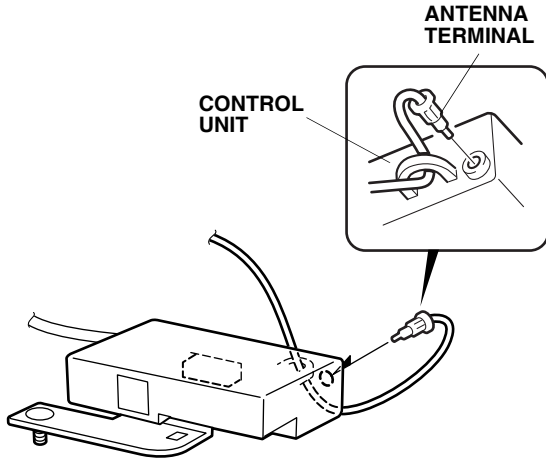

64. Insert the stud from the control unit bracket thru the hole in the vehicle frame and secure the control unit to the vehicle frame using the flange nut.

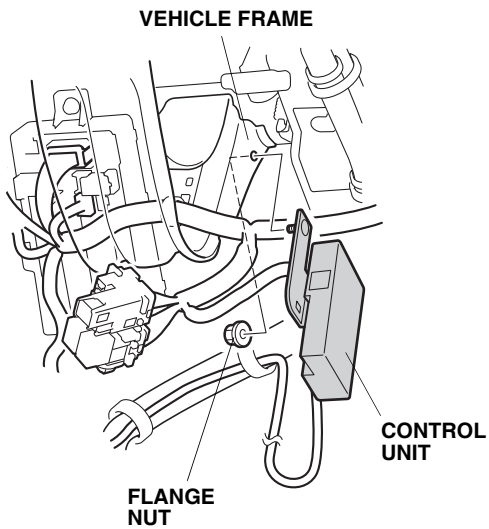

65. Clip the engine starter harness relay block to the vehicle frame.

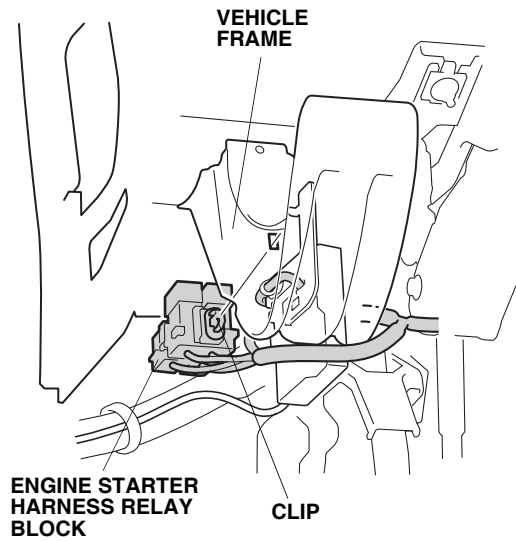

66. Bundle up the excess antenna cable, and insert the bundled cable under two wire ties loosely attached in step 59.

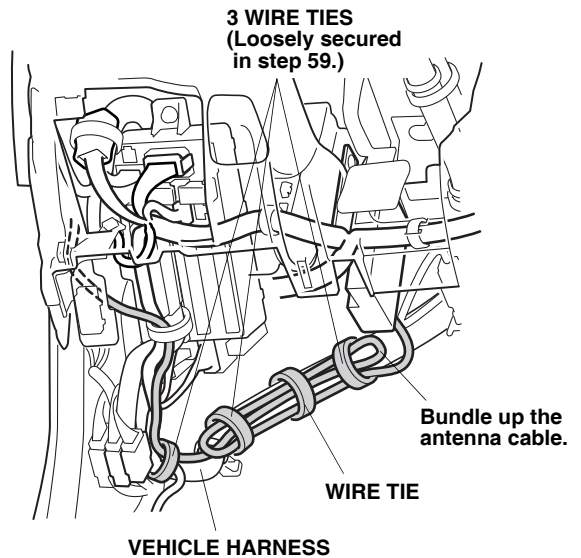

67. Secure the antenna cable to the vehicle harness with one additional wire tie.



68. Under the hood, locate the area where the caution label will attach. Using isopropyl alcohol on a shop towel, clean the hood where the caution label will attach.

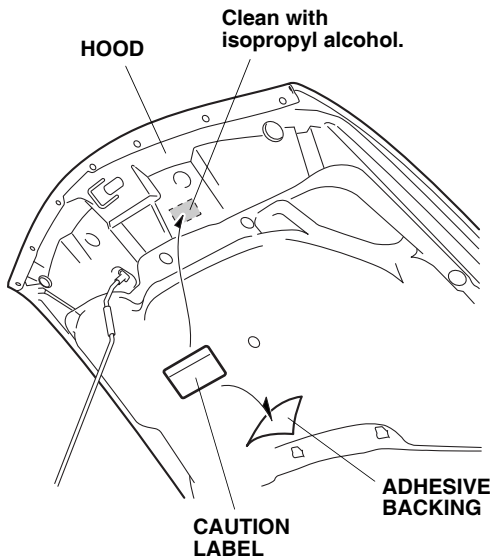

69. Attach the caution label to the hood at the area you just cleaned.

70. Check that all wire harnesses and cables are routed properly and that all connectors are plugged in.
71. Reinstall all removed parts. Check that all clips and other fasteners are installed securely. Take care not to pinch the side curtain airbag with the clip during reinstallation of the left front A-pillar trim. Do not push excessively on the front A-pillar trim.
72. Reconnect the negative cable to the battery. Check that the electrical accessory and other electrical systems function properly.
73. Enter the customer's radio anti-theft code and reset the radio station presets.
74. Reset the clock on the models without the navigation system.
75. Do the "REMOTE ENGINE STARTER REGISTRATION" and "FUNCTION CHECK."

## REMOTE ENGINE STARTER REGISTRATION

1. Acquire a PCM Code from ISIS.

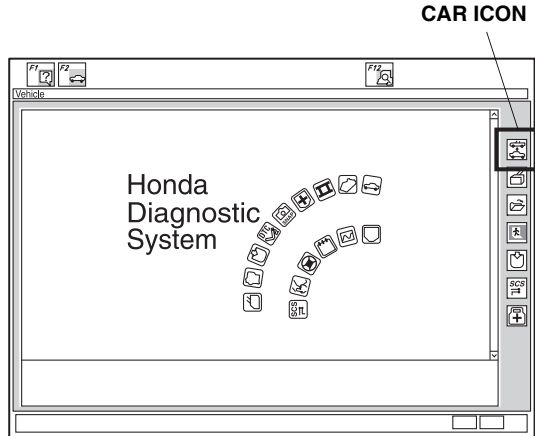

2. Connect the HDS tester to the OBD II data link connector, then turn the ignition switch on.
3. Start the HDS, and click the car icon.
4. Input the VIN and other requirements in accordance with the HDS, then click the check button.

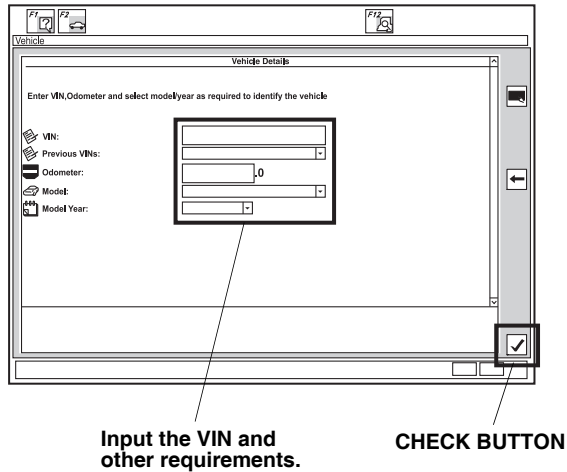

5. Select "Honda Systems", then click the check button.

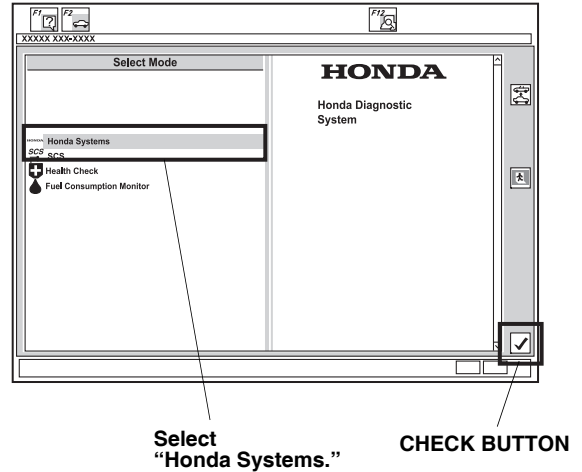

6. Select "R/C ENG STARTER" and click the check button.

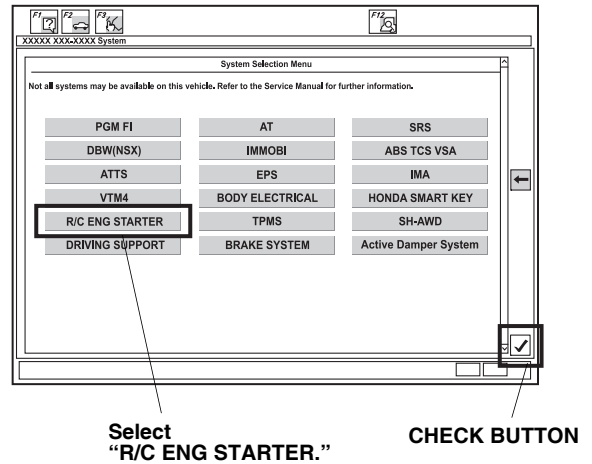

7. Check that "REMARKS" is shown, then click the check button.

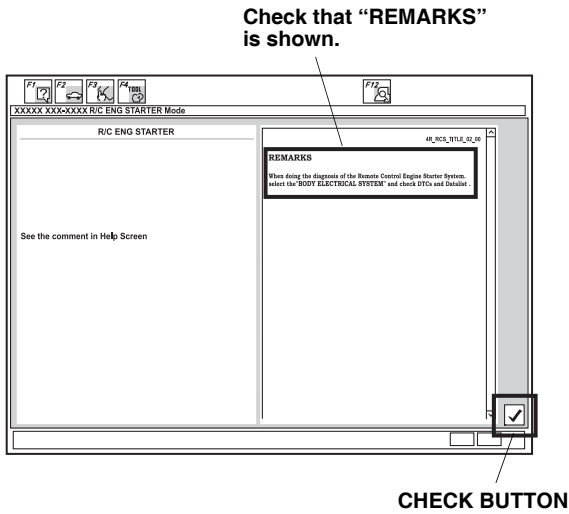

8. Select "REGISTER REMOTE CONTROL ENGINE STARTER UNIT", then click the check button.

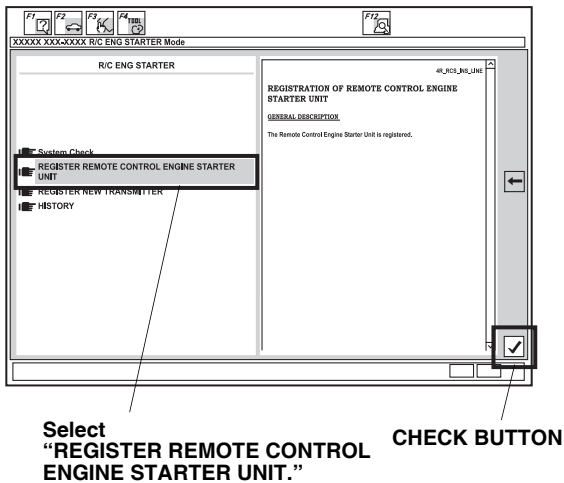

9. Check that "Obtain PCM-code (IMMOBILIZER PCM CODE) from iN. This vehicle's VIN will be required to obtain the password. (USA)" is shown, then click the check button.

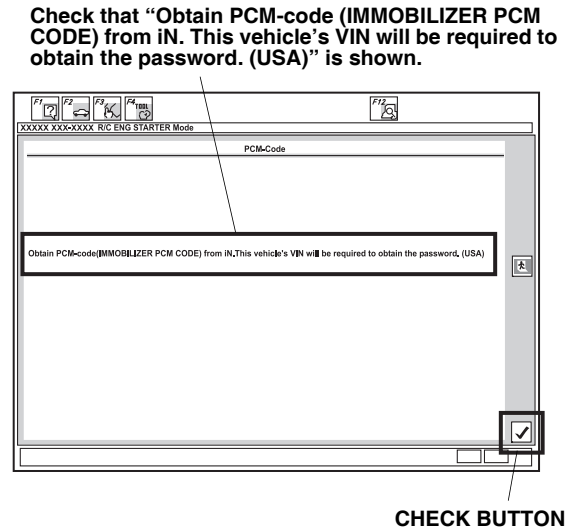

10. Input the PCM Code, then click the check button.
 

**NOTE:** To ensure security, the PCM code (password) is changed everyday, so it is impossible to register the remote controlled engine starter if the date of the PCM code acquisition and registration are different. The date of the HDS tester should also be the same.

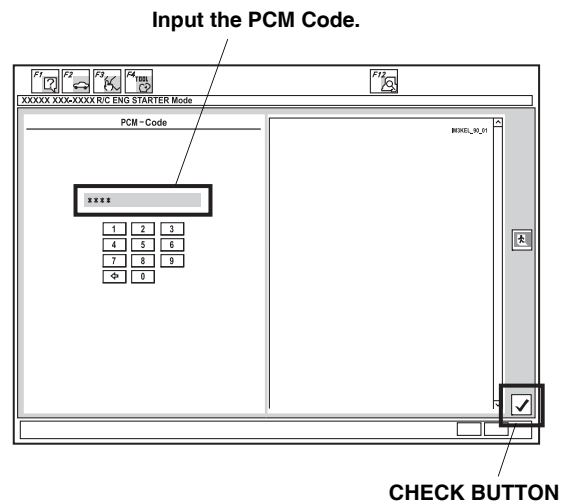

11. Check that “The registration of the Remote Control Engine Starter Unit has been completed” is shown, then click the check button.

**Check that “The registration of the Remote Control Engine Starter Unit has been completed” is shown.**

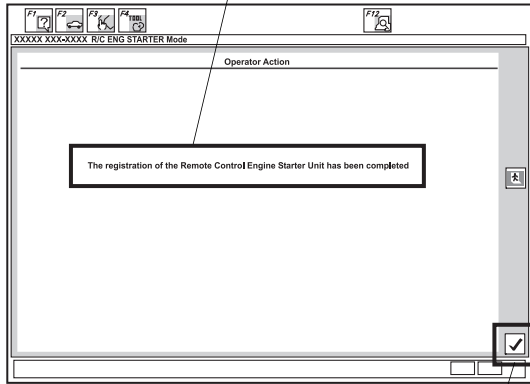

**CHECK BUTTON**

12. Check that “Check that the engine can be started by the Transmitter” is shown, then click the check button.

**Check that “Check that the engine can be started by the Transmitter” is shown.**

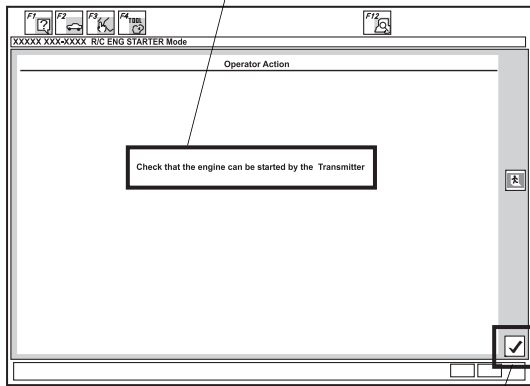

**CHECK BUTTON**

13. Perform the function test on the next page, then remove the HDS.

## FUNCTION CHECK

### Operating Conditions

- Hood is closed
- Shift lever in park
- The key is out of the ignition switch
- All doors and trunk lid closed and locked

### Inspection

1. Within 1 second, press the command button, and then the start button on the transmitter.  
The engine should start if all operating conditions are met.

Does the engine start?

Yes - Operation is normal.
No: <ul style="list-style-type: none"><li>• Make sure all "Operating Conditions" are met.</li><li>• Check the engine starter harness connections.</li><li>• Connect the HDS and check for an indicated failure. (Refer to the appropriate service manual for details.)</li></ul>

2. Press the command button on the transmitter, and within 1 second, press the stop button. The engine should stop.

Does the engine stop?

Yes - Operation is normal.
No - Check the engine starter harness connections.

3. After the engine has stopped, start the engine again, and check that the engine stops after each of the following conditions:

#### NOTE:

- After each test the ignition switch must be cycled, or the driver's door must be opened and closed.
  - Move the shift lever out of the P position.
  - Unlock or open the doors or the trunk lid.
  - Open the hood.
  - Insert the key in the ignition switch.
  - Press the brake pedal.

Does the engine stop after each of these tests?

Yes - Operation is normal.
No - Check the engine starter harness connections.

4. Check that the power window or the moonroof does not function and the shift lever does not move to any position but the P position when the engine is started with the transmitter.
5. Press the command button on the transmitter two times, and check the vehicle condition on the display.
6. Check the operation of the transmitter when the vehicle is 100 m to 150 m (325 to 490 ft.) away and in direct sight.

