



INSTALLATION INSTRUCTIONS

Accessory
ENGINE BLOCK HEATER
P/N 08T44-SNA-101

Application
2010 TL

Publications No.
BII 42527
Issue Date
AUG 2009

PARTS LIST

Engine block heater

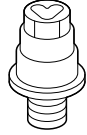

Aluminum washer



Heater harness

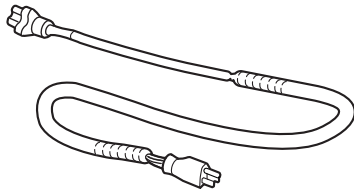

Protective cap

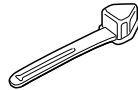

12 Black wire ties
(6 Not used)

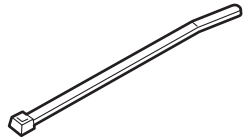

7 Wire ties with clip
(6 Not used)

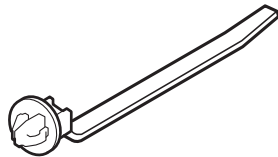

5 White wire ties
(2 Not used)

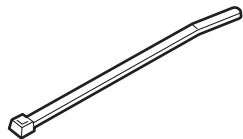

TOOLS AND SUPPLIES REQUIRED

Phillips screwdriver

Flat-tip screwdriver

Ratchet

10 mm, 19 mm, and 24 mm Sockets

Long extension

Torque wrench

Diagonal cutters

Heavy gloves

Drain pan

Tape measure

White marker

Honda All Season Antifreeze/Coolant Type 2

Fender cover

Blanket

Plastic Trim Tool (T/N SILTRIMTL10)

NOTE: Using a longer extension may damage the engine block heater while torquing.

INSTALLATION

Client Information: The information in this installation instruction is intended for use only by skilled technicians who have the proper tools, equipment, and training to correctly and safely add equipment to your vehicle. These procedures should not be attempted by “do-it-yourselfers.”

NOTE:

- Always use Honda All Season Antifreeze/Coolant Type 2. Using a non-Honda coolant can result in corrosion, causing the cooling system to malfunction or fail.
 - To avoid burning out the element, do not operate the engine block heater until it is installed in the vehicle and you add coolant.
1. Make sure you have the anti-theft codes for the audio and navigation system (if equipped), then write down the audio presets.
 2. Allow the engine and all cooling system components to cool down.
 3. Open the hood, and remove the front engine cover (four clips and two hooks).

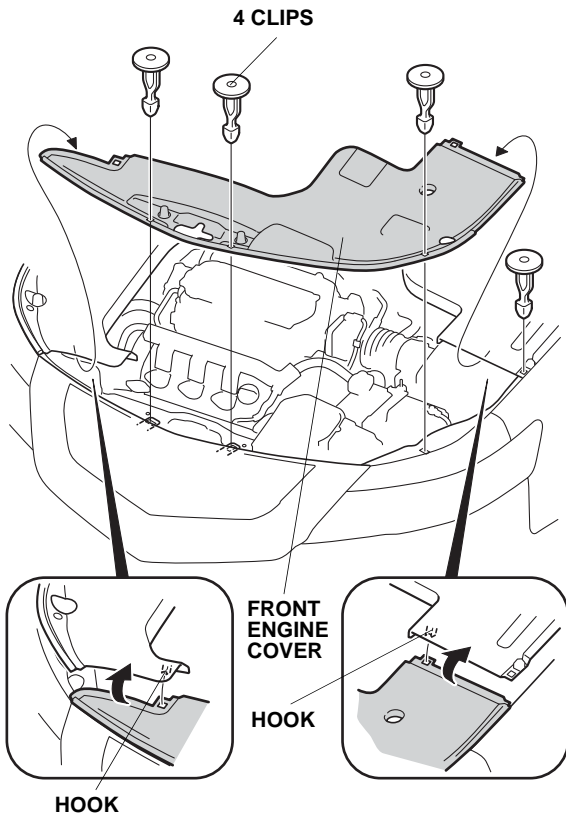

4. Disconnect the negative cable from the battery.

5. Place a clean drain pan under the radiator drain plug, then remove the drain plug from the bottom of the radiator to drain the coolant. Remove the radiator cap to increase the flow.

NOTICE: Radiator coolant will damage paint. Quickly rinse any spilled coolant from painted surfaces.

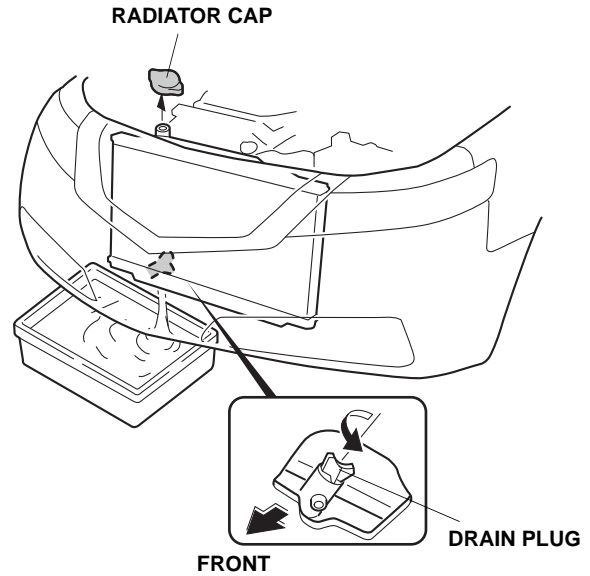

6. Remove the two clips, and raise the right upper fender trim.

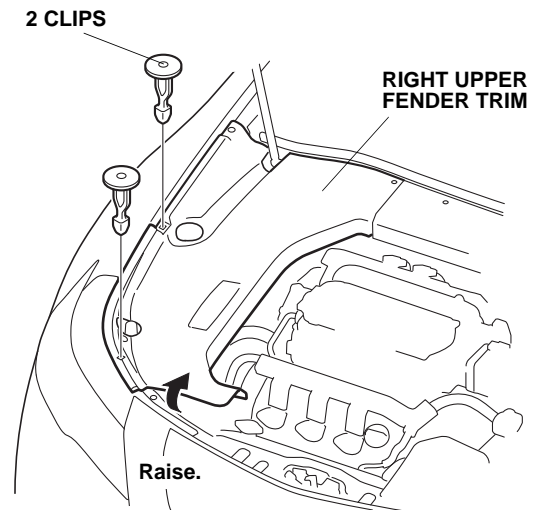

7. Remove the four bolts from the upper grille.

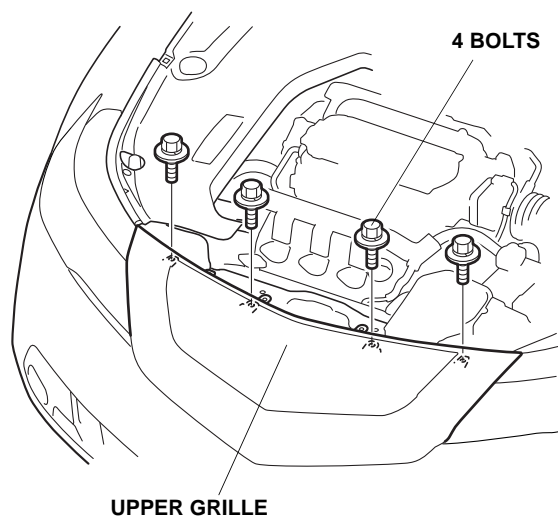

8. Remove the air duct (three clips).

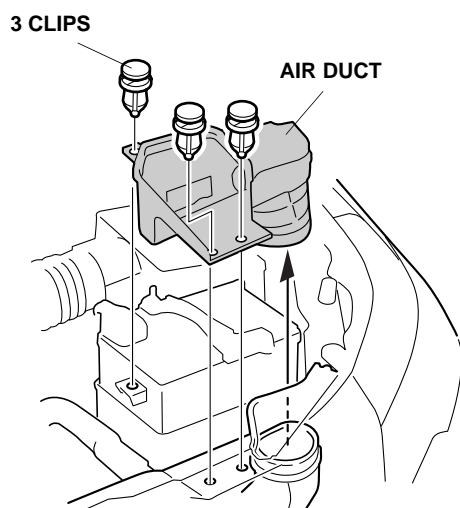

9. Remove the left front air spoiler (three bolts and one clip).

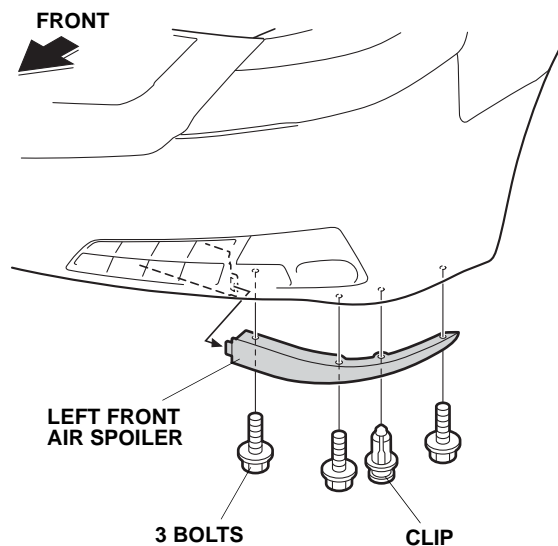

10. Remove the right front air spoiler the same way.

11. Remove the two self-tapping screws, four clips, and two bolts from the front bumper.

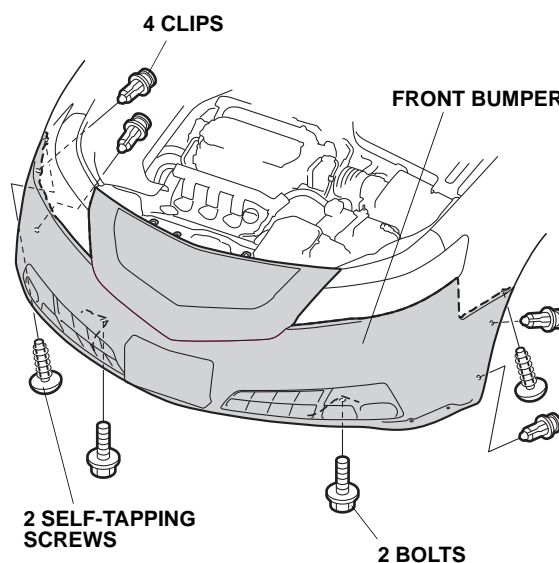

12. On each side, release the eleven hooks, and pull the front bumper out from the body.

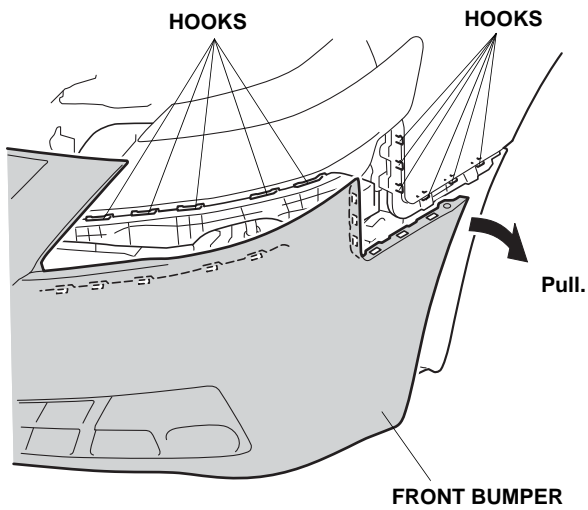

13. With the help from an assistant, remove the front bumper (two vehicle clips and unplug the five vehicle connectors). Place the front bumper on a blanket to prevent damage.

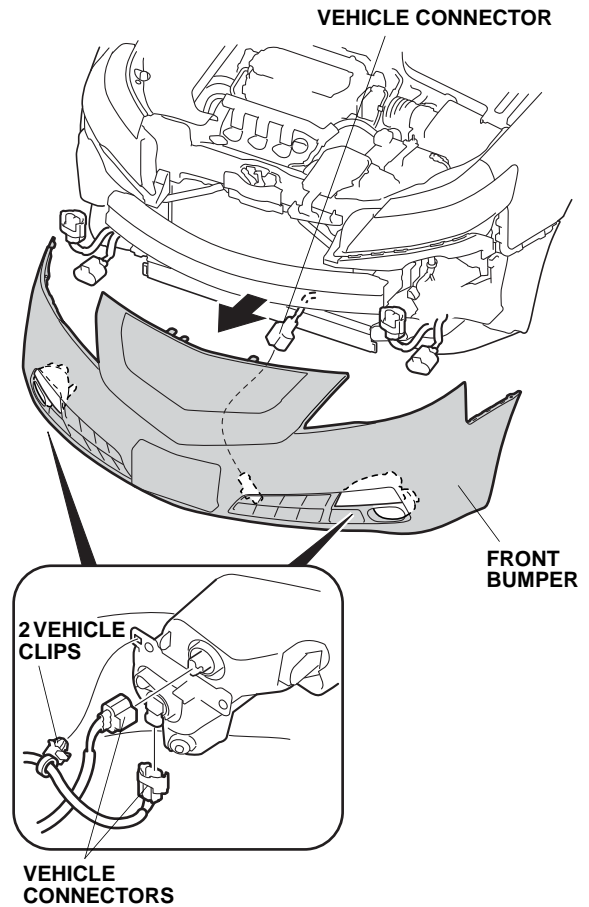

Installing the Engine Block Heater

- Unplug the vehicle connector, and remove the vehicle connector from the vehicle bracket.

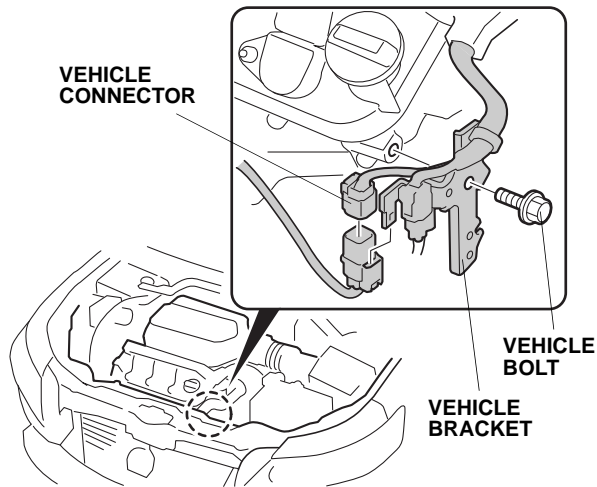

- Remove the vehicle bolt, and release the vehicle bracket.
- Using a 19 mm socket and a 3 inch long extension, remove the drain bolt and washer from the engine block. Remaining coolant will drain from the engine block when the bolt is removed. Retain the bolt; it will be used if the engine block heater is removed. **NOTE:** Use a new washer if the drain bolt is reinstalled.

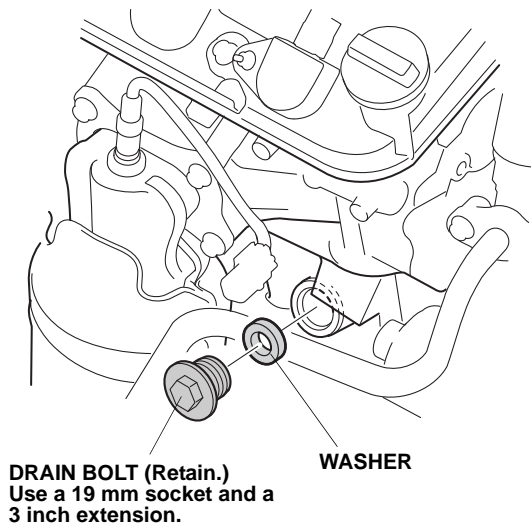

- Install the engine block heater with the aluminum washer into the hole using a 24 mm socket. Torque the engine block heater to 60 N·m (44 lbf·ft). Use a 24 mm socket.

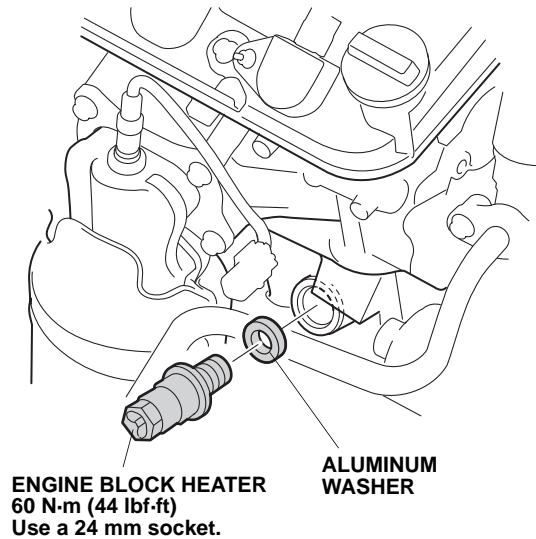

- Get the heater harness. Using a tape measure, install a wire tie with clip to the heater harness at each measurement shown. Using a white marker, measure and mark the heater harness at the locations shown.

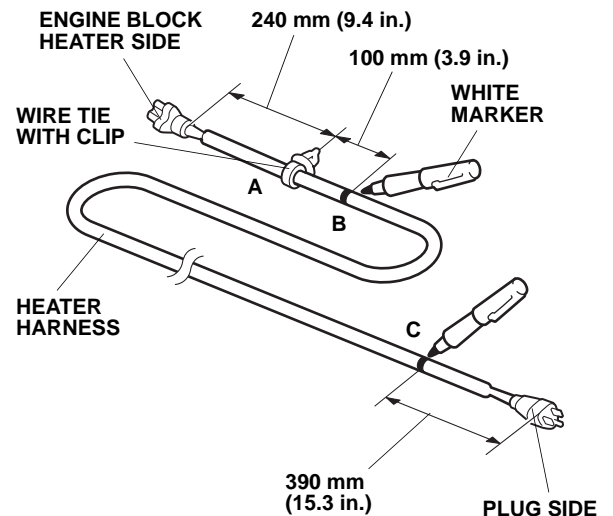

19. Reinstall the vehicle bracket with the vehicle bolt removed in step 15. Reattach the vehicle connector to the vehicle bracket, and plug in the vehicle connector.

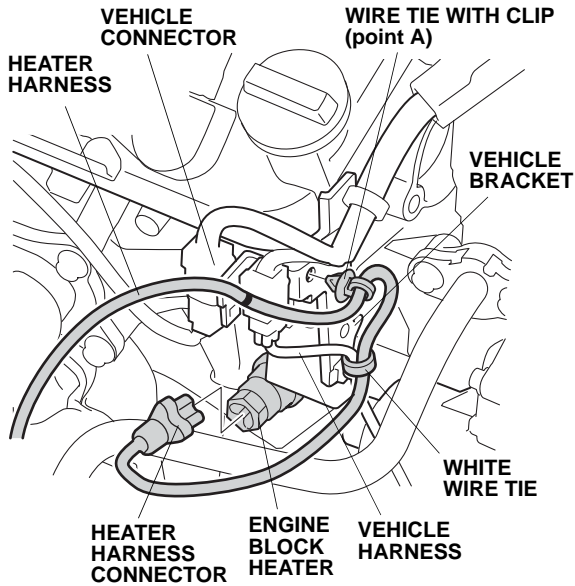

20. Plug the heater harness connector into the engine block heater. Route the heater harness as shown, and secure the one wire tie with clip (point A) to the vehicle bracket.
21. Secure the heater harness to the vehicle harness using one white wire tie.

22. Route the heater harness as shown. Align the white mark (point B) on the heater harness with the end of the fan frame, and secure the heater harness to the fan frame using one white wire tie over the white mark.

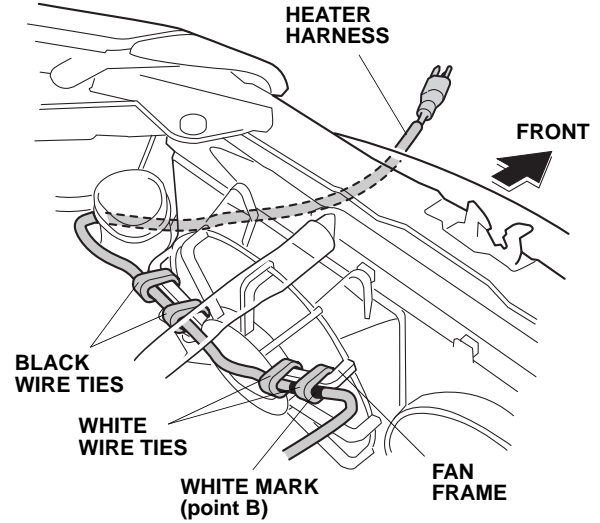

23. Secure the heater harness to the ends of the fan frame using an additional white wire tie and two black wire ties.
24. Align the white mark (point C) on the heater harness with the vehicle clip, and secure the heater harness to the vehicle harness using one black wire tie.

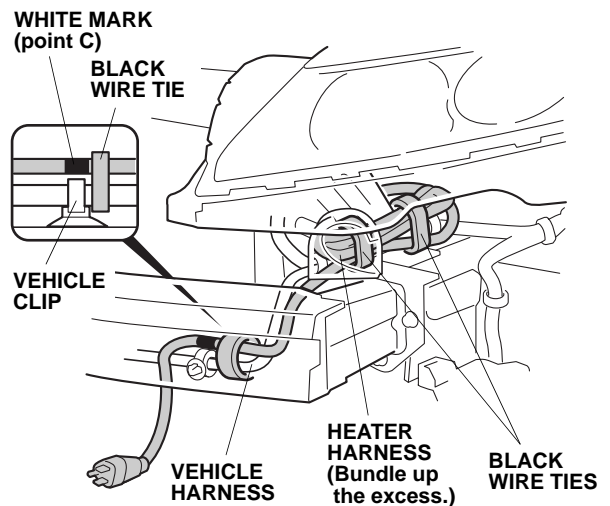

25. Bundle up the excess heater harness, and secure it to the vehicle harness using two black wire ties as shown.

26. With the help of an assistant, move the front bumper close to the vehicle. Route the heater harness to the front bumper grille as shown, and reinstall the front bumper.

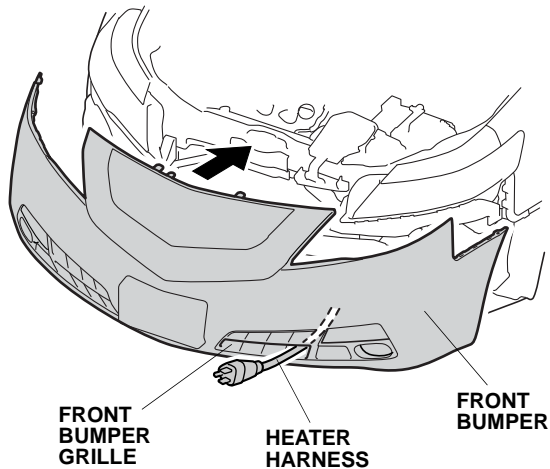

27. Secure the heater harness to the front bumper grille using one black wire tie.

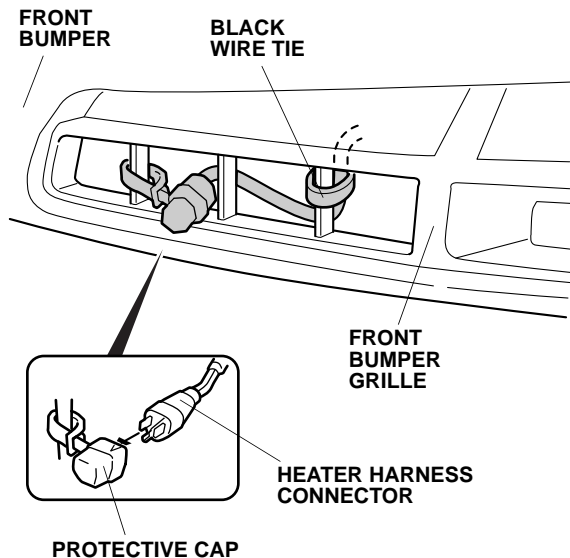

28. Attach the protective cap to the front bumper grille, and plug the heater harness connector into the protective cap.

29. Reinstall all removed parts except for the radiator cap and the front engine cover.
30. Check that the heater harness is routed properly and all connectors are plugged in.
31. Reconnect the negative cable to the battery.
32. Reinstall the radiator drain plug.
33. Fill the system with the recommended coolant. Follow the instructions described in the service manual to fill and bleed the cooling system.
34. Check the coolant reservoir for correct level and check the cooling system for signs of leakage. Repair as necessary.
35. Reinstall the radiator cap and the front engine cover.
36. Put the drain bolt (removed in step 16) in the glove box.
37. Enter the anti-theft codes for the audio system and the navigation system (if equipped).
38. Reset the clock on vehicles without navigation.