



INSTALLATION INSTRUCTIONS

Accessory
ALL-SEASON MATS

Application
2010 TL

Publications No.
BII 42520
Issue Date
AUG 2009

PARTS LIST

All-Season Mats
P/N 08P13-TK4-210 (Black)
P/N 08P13-TK4-220 (Caramel)
Driver's side all-season mat

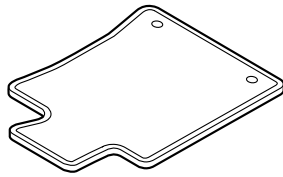

Passenger's side all-season mat

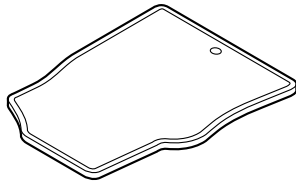

Left rear all-season mat

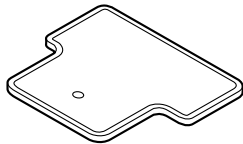

Right rear all-season mat

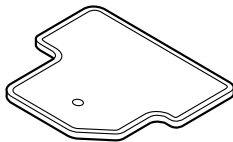

All-Season Mats (AWD)
P/N 08P13-TK5-210 (Black)
P/N 08P13-TK5-220 (Caramel)

Driver's side all-season mat

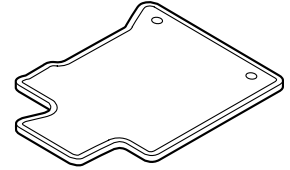

Passenger's side all-season mat

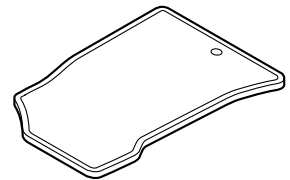

Left rear all-season mat

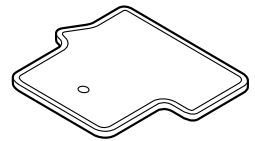

Right rear all-season mat

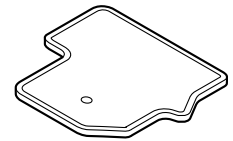

INSTALLATION

NOTE:

- An anchor is required for the driver's side of the vehicle; the anchor prevents the front mat from sliding forward and possibly interfering with the pedals.
- If you remove the front mat, make sure you reanchor it when you put it back in your vehicle.
- If you replace the mat, use factory mats designed to be used with the anchor
- If you use a non-factory mat in the driver's footwell, make sure it fits properly and that it can be used with the anchor.
- Do not put additional mats on top of the anchored mat, otherwise the additional mats may slide forward and possibly interfere with the pedals.
- Identify each mat by the marks on the back of each mat: the mats marked "R" or "Passenger's side" go on the right side of the vehicle; the mats marked "L" or "Driver's side" go on the left side.

Installing the All-Season Mats

1. Position the driver's side all-season mat by aligning the tabs with their respective grommets.

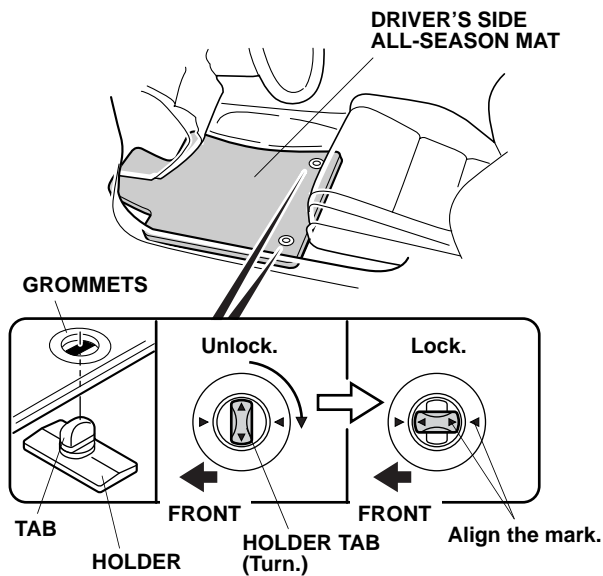

2. Turn the tabs of the holders one quarter turn to secure the all-season mat.

3. Position the passenger's side all-season mat by aligning the tab with their grommet.

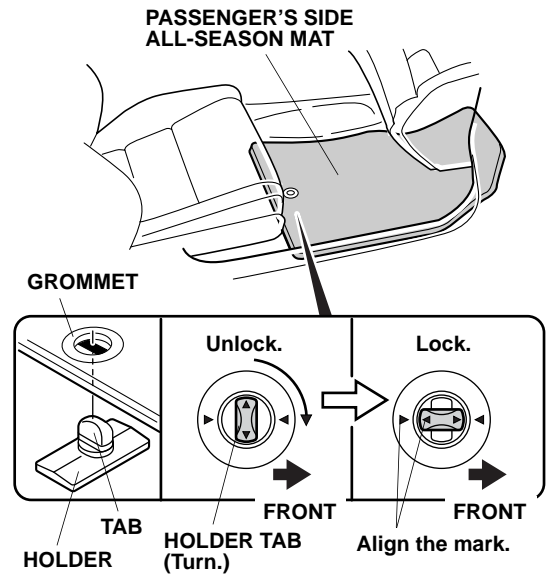

4. Turn the tab of the holder one quarter turn to secure the all-season mat.
5. Position the right and left rear all-season mats by aligning each tab with each grommet.

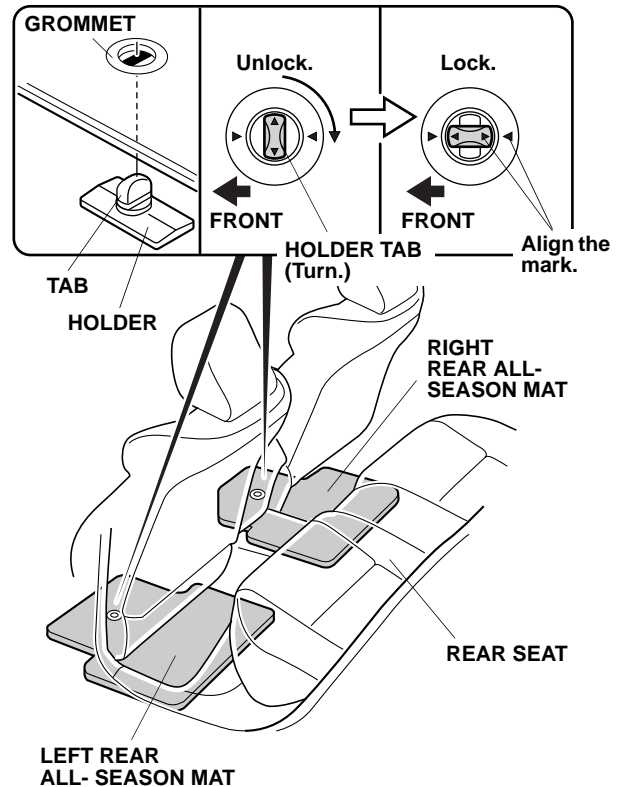

6. Turn the tab of the each holder one quarter turn to secure the all-season mats.