



ACURA INSTALLATION INSTRUCTIONS

Accessory	Application	Publications No.
INTERIOR PANEL	2010 RDX	BII 41793
		Issue Date
		JUNE 2009

PARTS LIST

Front passenger side panel

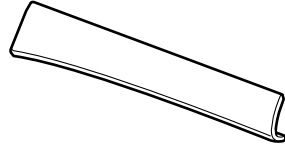

Right driver side panel

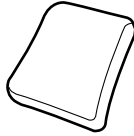

Left driver side panel

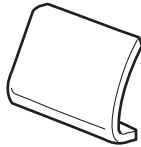

TOOLS AND SUPPLIES REQUIRED

Isopropyl alcohol

Shop towel

Masking tape

INSTALLATION

1. Clean the existing front passenger side panel with isopropyl alcohol.

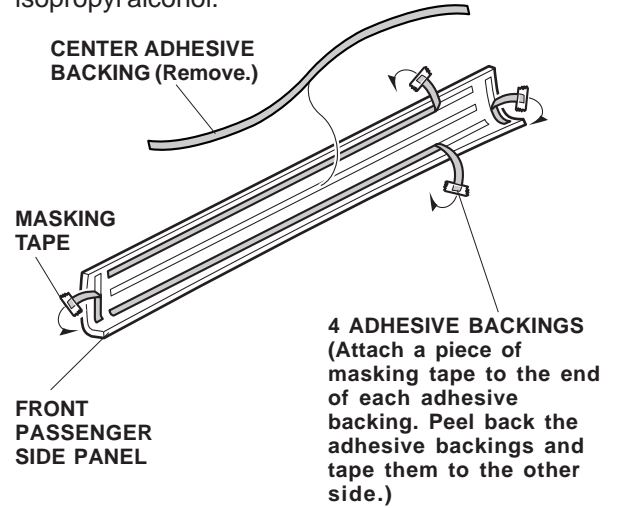

2. Attach a piece of masking tape to an end of each of the four adhesive backings on the inner side of the front passenger side panel. Peel back 1-2 inches (2-6 cm) from the adhesive backings and temporarily attach them to the front surface of the front passenger side panel. Remove the entire center adhesive backing from the front passenger side panel.
3. Position the front passenger side panel on the existing panel. Gently press on the front passenger side panel with the palm of your hand while removing the adhesive backings.

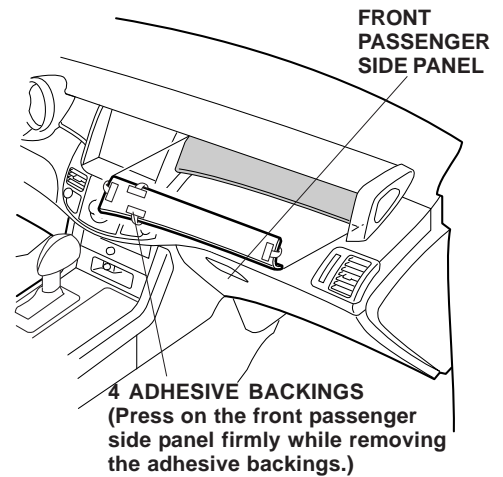

4. Press and hold the side panel for 30 seconds.

- Clean the right driver side panel where the new side panel will attach using isopropyl alcohol on a shop towel.

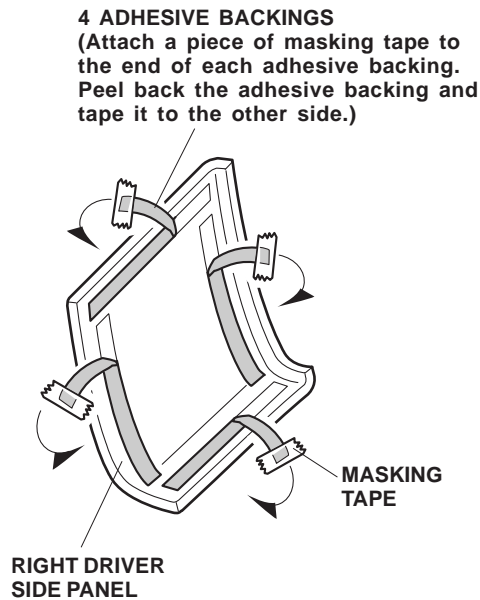

- Attach a piece of masking tape to one end of each of the four adhesive backings on the inner side of the right driver side panel. Peel back 1-2 inches (2-6 cm) from the adhesive backings and temporarily attach them to the front surface of the right driver side panel.
- Position the right driver side panel on the installation surface. Press on the right driver side panel firmly with the palm of your hand while removing the adhesive backings.

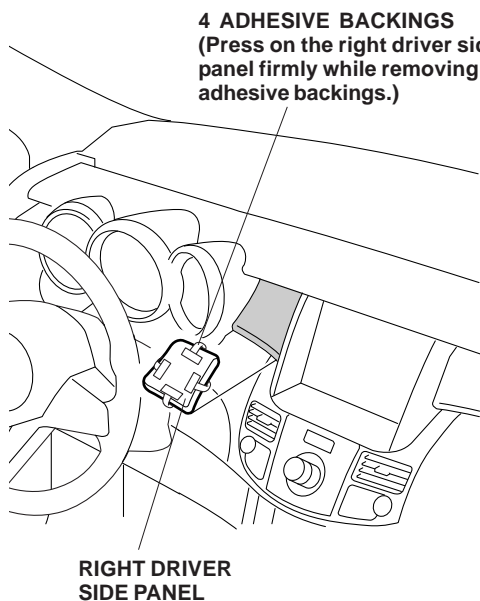

- Clean the position where the left driver side panel will be installed and clean the surface using isopropyl alcohol.

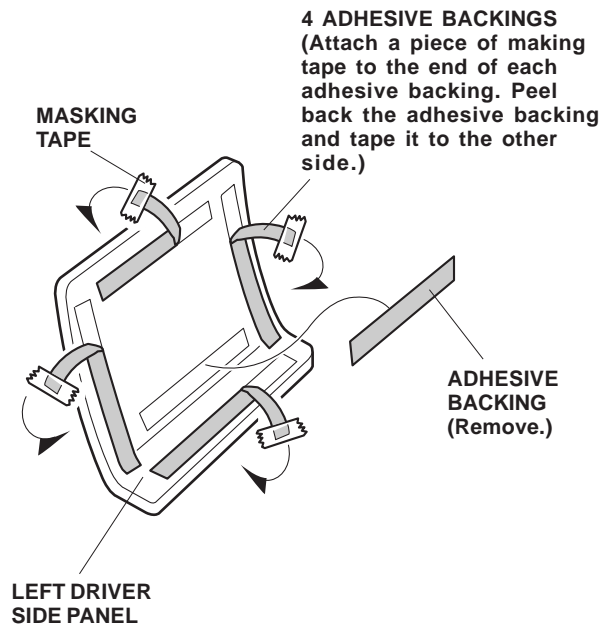

- Attach a piece of masking tape to an end of each of the four adhesive backings on the inner side of the left driver side panel. Peel back 1-2 inches (2-6 cm) from the adhesive backings and temporarily attach them to the front surface of the left driver side panel.
- Position the left driver side panel on the installation surface. Press on the left driver side panel firmly with the palm of your hand while removing the adhesive backings.

