



# INSTALLATION INSTRUCTIONS

Accessory  
**BACK-UP SENSORS**

Application  
**2010 RDX**

Publications No.  
**BII 41782**  
Issue Date  
**AUG 2009**

## PARTS LIST

### Backup Sensor Attachment Kit P/N 08V67-STK-200A

Control unit

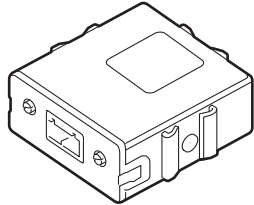

Buzzer

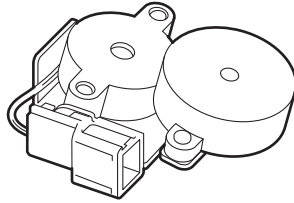

Back-up sensor harness

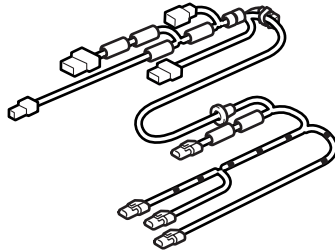

Control unit bracket

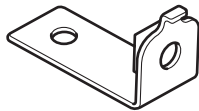

Switch

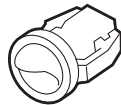

13 Wire ties

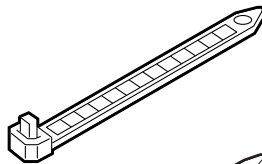

2 Short wire ties  
(not used)

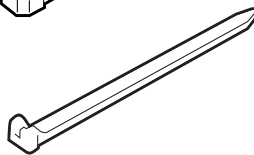

8 Cushion tapes

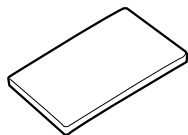

7 Cable clips



Screw grommet



2 Clips A (with center tab)

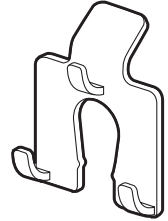

2 Clips B (with side tab)

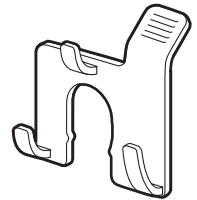

Special screw



Self-tapping screw



Collar



Fuse label

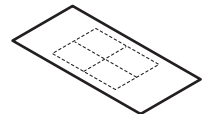

Accessory user's information manual

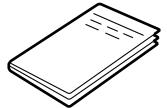

## Back-up Sensor Kit

2 Corner sensors A

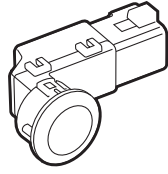

2 Center sensors B  
(with blue connector)

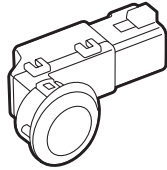

## TOOLS AND SUPPLIES REQUIRED

Phillips screwdriver  
Flat-tip screwdriver  
Ratchet  
8 mm and 10 mm Sockets  
Pushpin  
Drill  
3 mm Drill bit  
20 mm, 24 mm, and 26 mm Hole saw  
Scale  
Eye protection (safety goggles, face shield, etc.)  
10 mm Combination wrench  
File  
Diagonal cutters  
Utility knife

## Illustration of the Back-Up Sensors Installed on the Vehicle

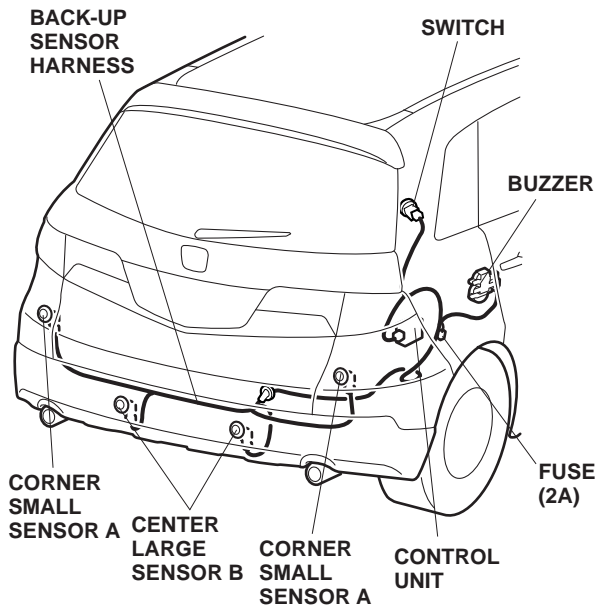

## INSTALLATION

**Client Information:** The information in this installation instruction is intended for use only by skilled technicians who have the proper tools, equipment, and training to correctly and safely add equipment to your vehicle. These procedures should not be attempted by "do-it-yourselfers."

1. Make sure you have the anti-theft code for the radio and navigation system, then write down the radio presets.

2. Disconnect the negative cable from the battery.

### Installing the Sensors in the Bumper

3. Open the tailgate. Remove the cargo area cover.

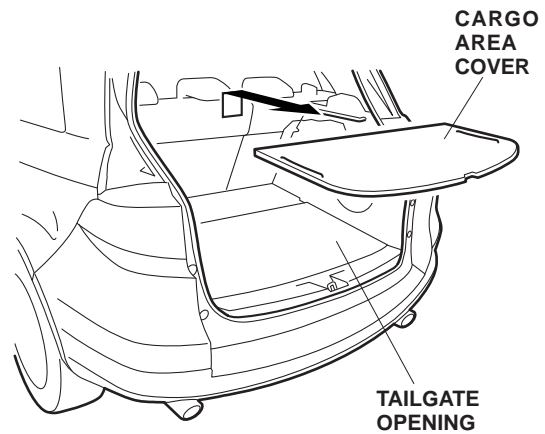

4. Remove the cargo area floor lid.

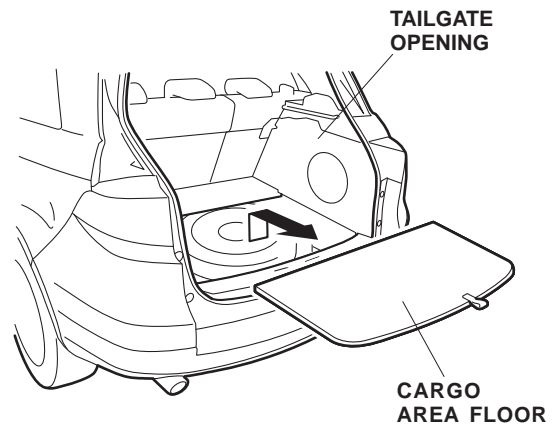

- Remove the cargo area lid (four clips).

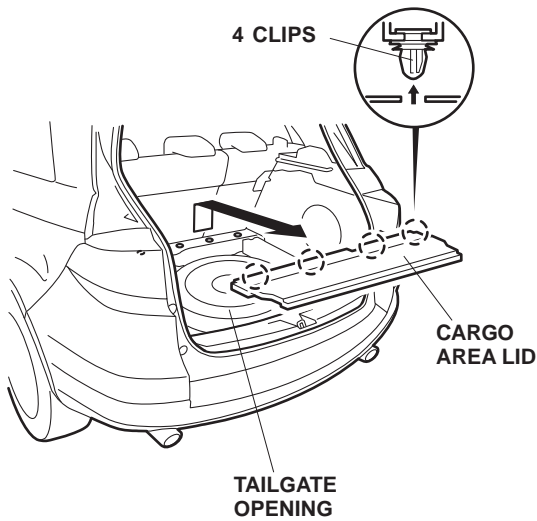

- Remove the tailgate weatherstrip in the area shown.

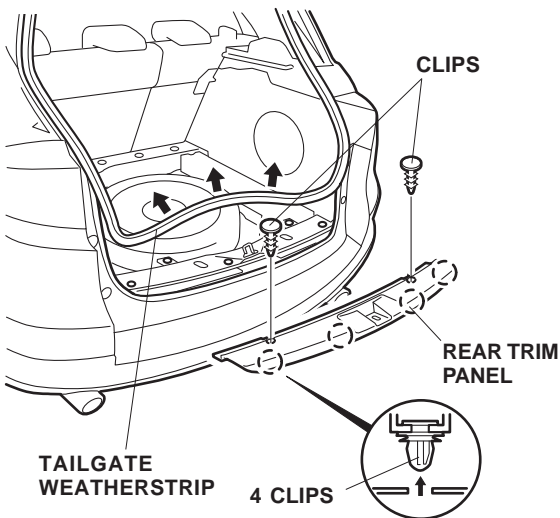

- Remove the two clips from the rear trim panel. Remove the rear trim panel (four clips).

- Fold the right rear seat cushion forward, and lay the seat-back flat.

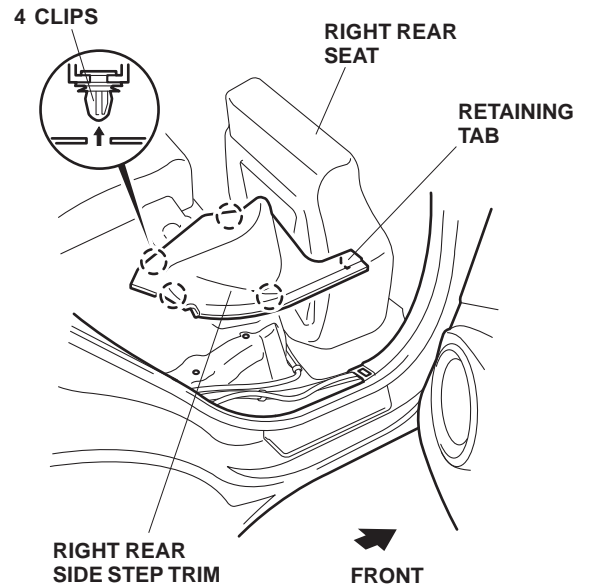

- Remove the right rear side step trim (four clips and one retaining tab).
- Remove the door weatherstrip in the area shown.

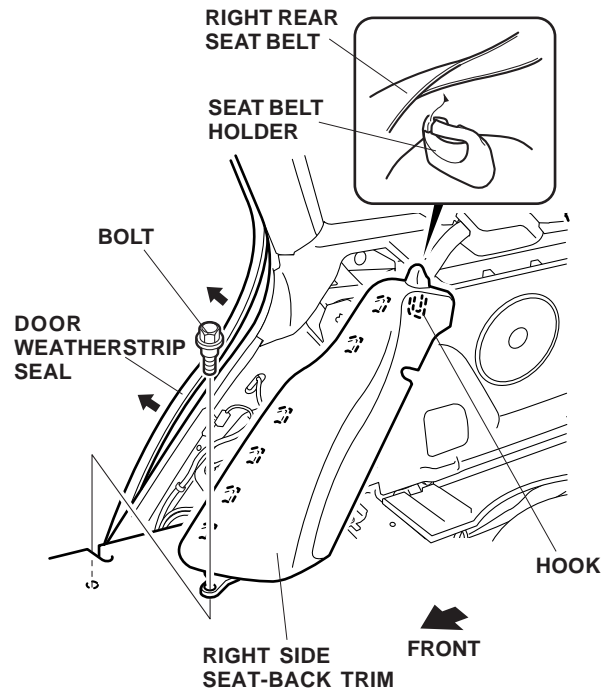

- Remove the right side seat-back trim (one bolt and one hook) and remove the right rear seat belt from the seat belt holder.

- Open the right front cover tie-down hook. Remove the front tie-down hook from the right side trim panel (one screw).

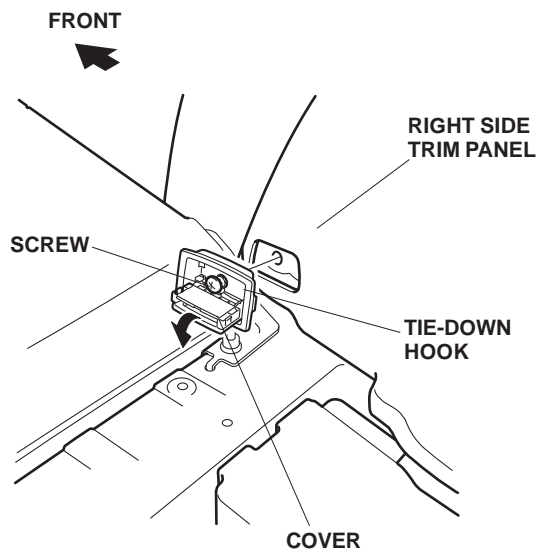

- Open the right rear cover tie-down hook. Remove the rear tie-down hook from the right side trim panel (one screw).

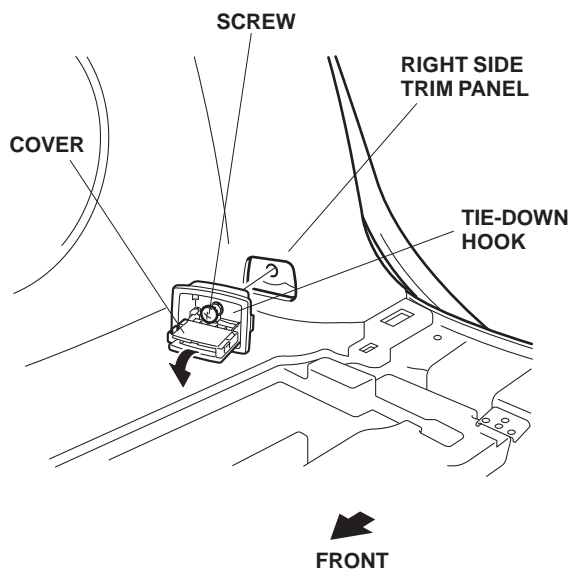

- Remove the bolt cover from the right side trim panel, and remove the two bolts and three clips.

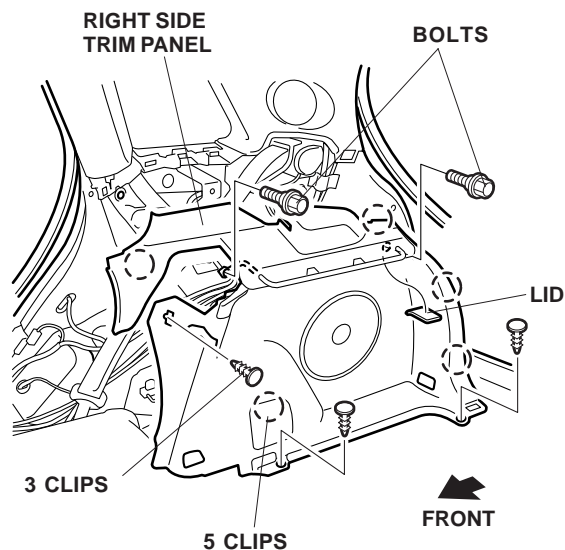

- Remove the right side trim panel (five clips). Push along on the top to release the top clips between the two panels.
- Remove the right floor spacer.

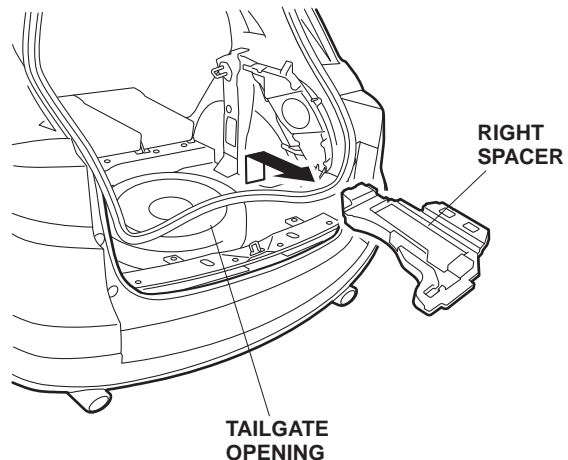

17. Remove the right rear speaker (two nuts and three bolts, and unplug the vehicle connector).

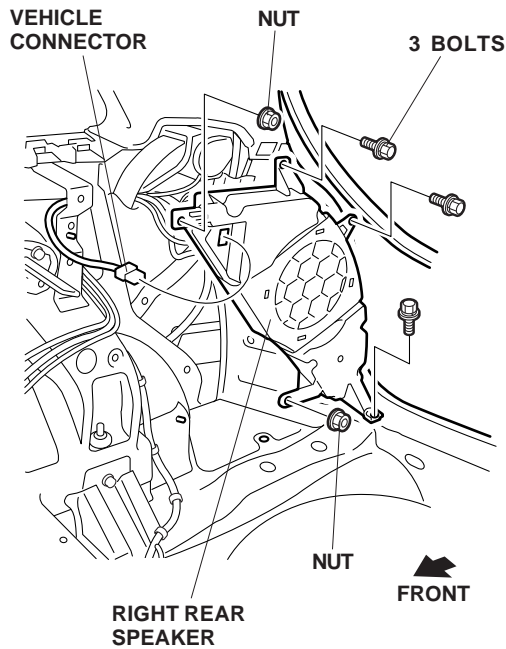

18. Remove the right quarter pillar trim (six clips).

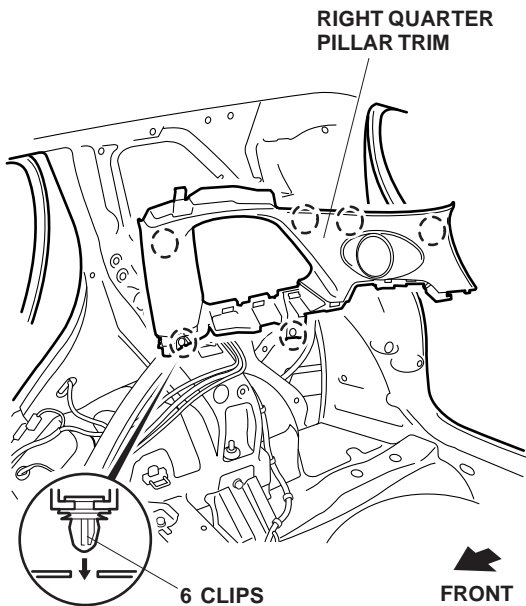

19. Remove the four caps and four bolts from the rear bumper. Have an assistant help you when removing and installing the rear bumper.

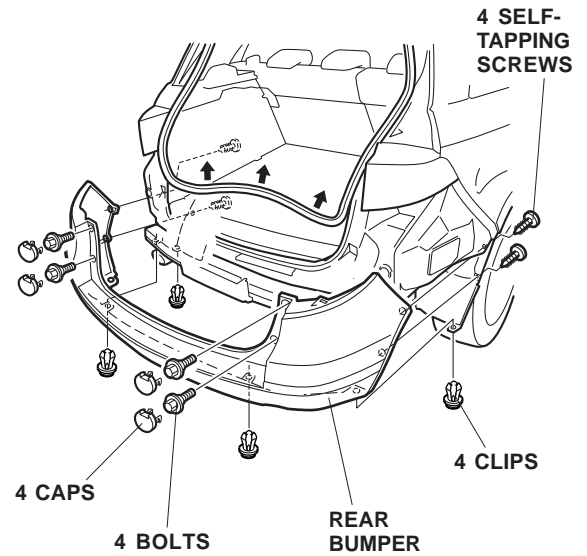

20. Remove the rear bumper (four self-tapping screws and four clips).
21. On the inside of the rear bumper, locate the four back-up sensor presets. Using a pushpin, mark the center and top of each of the four presets.

NOTE: The top 3 mm hole locates the direction of the sensor.

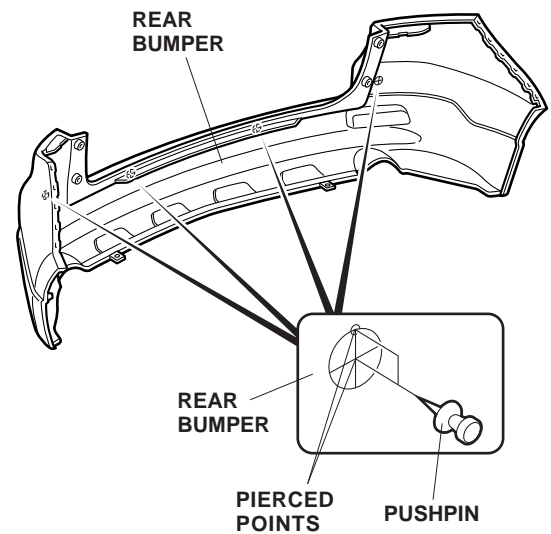

22. While wearing eye protection, drill a 3 mm pilot hole through each of the eight pierced points you just made from the outside surface of the rear bumper.

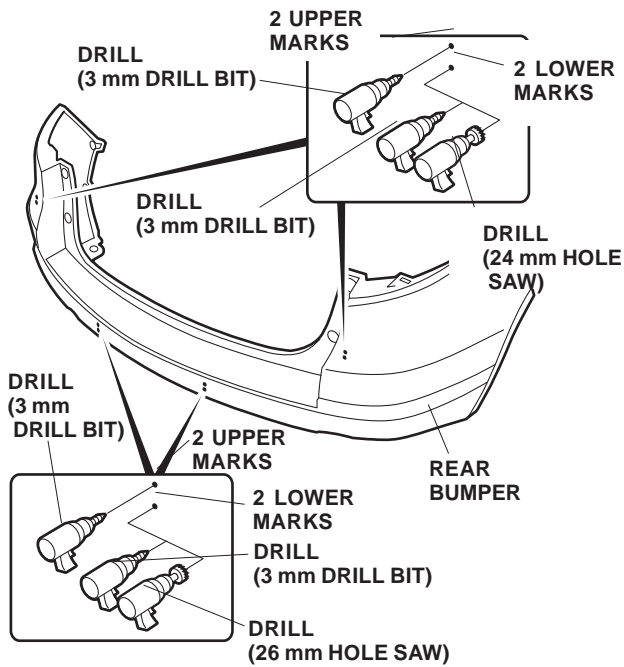

23. While wearing eye protection, enlarge the hole at each of the lower marks (center) using a 24 mm hole saw (outer holes) and a 26 mm hole saw (inner holes). Remove all burrs.

24. Install the two corner sensors A and clips A into the outer holes and two center sensors B and clips B into the inner holes on the rear bumper.

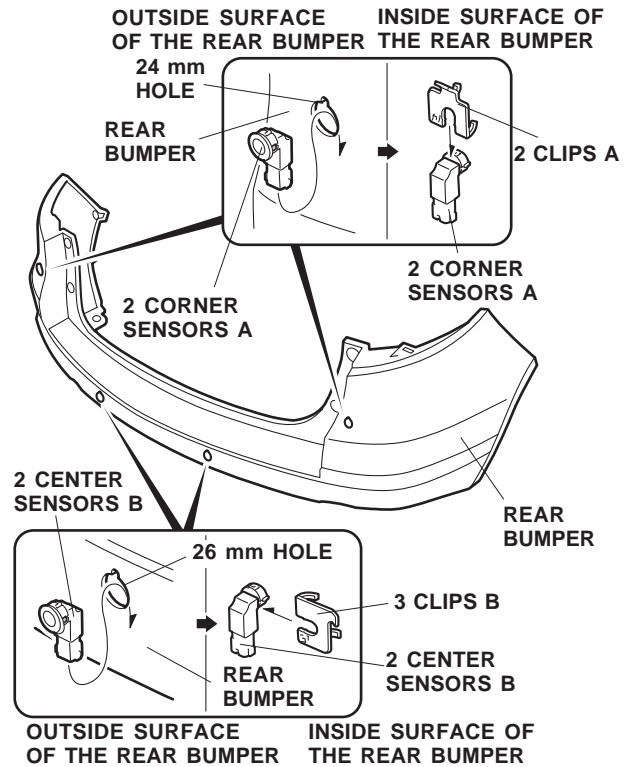

25. Inside the tailgate opening, locate and remove the vehicle grommet.

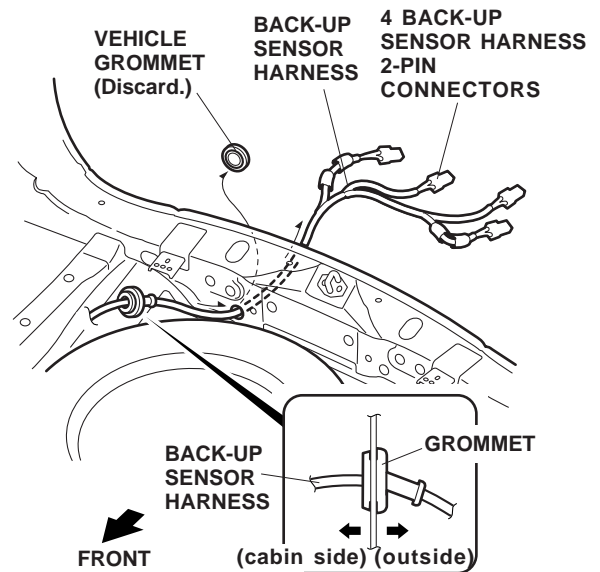

26. Route the four back-up sensor harness 2-pin connectors through the vehicle panel. Seat the back-up sensor harness grommet in the hole.
27. Secure the back-up sensor harness to the vehicle panel with one wire tie. Using isopropyl alcohol, thoroughly clean the areas where the cushion tape will attach. Route the back-up sensor harness toward the front of the vehicle and secure it to the vehicle panel with the three cushion tapes.

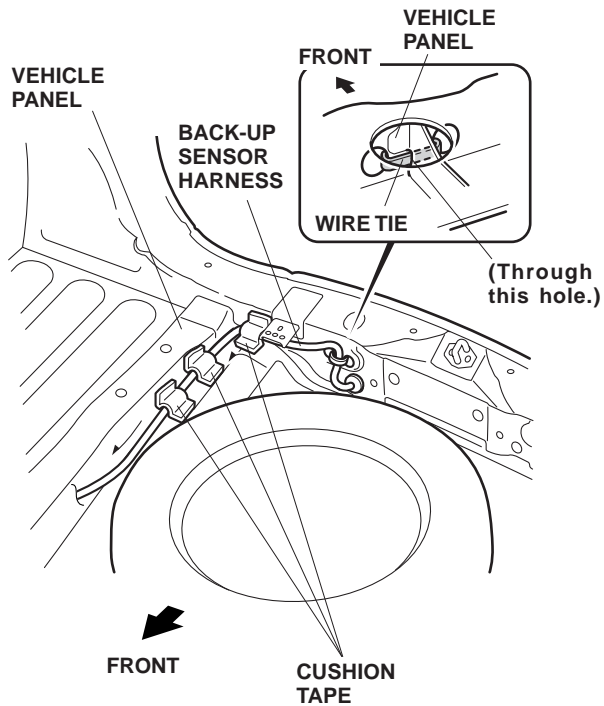

28. Route the back-up sensor harness forward and secure it to the vehicle panel with the two cushion tapes.

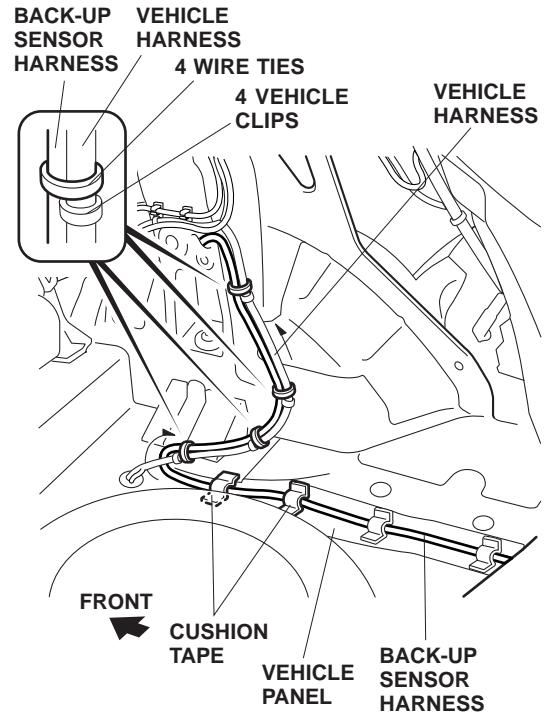



29. Continue to route the back-up sensor harness along the vehicle harness and secure it to the vehicle harness with the four wire ties (secure the wire ties beside the vehicle clips).
30. Route the back-up sensor harness 5-pin (green) connector forward and secure it to the vehicle harness with the three wire ties.

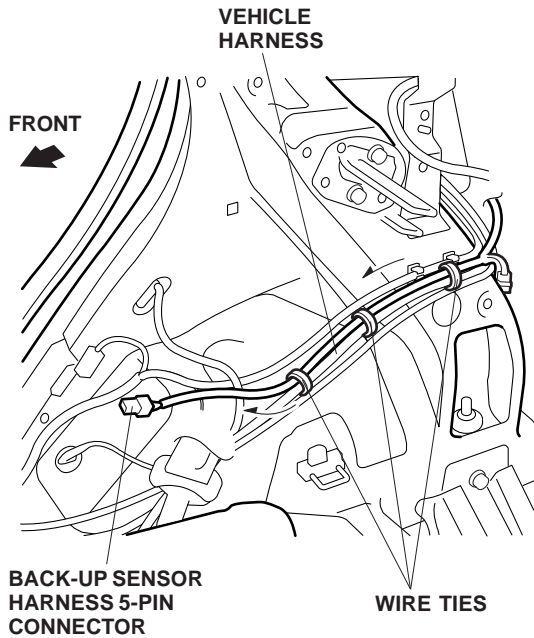

31. Install the screw grommet (supplied) into the vehicle panel hole in the area shown.

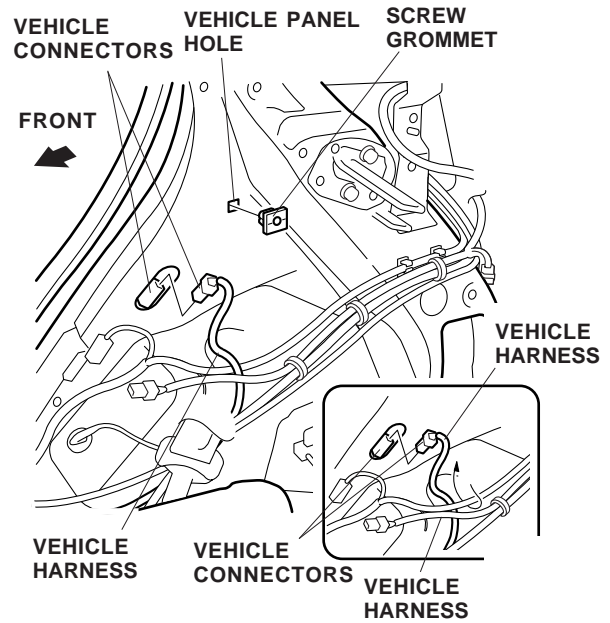

32. Disconnect the vehicle connector. Inside the vehicle panel, route the vehicle harness under the existing vehicle connector running along the fenderwell panel and reconnect the vehicle connector.



33. Using isopropyl alcohol, thoroughly clean the vehicle panel area where the cushion tape will attach. Secure the back-up sensor harness to the vehicle panel with one cushion tape.

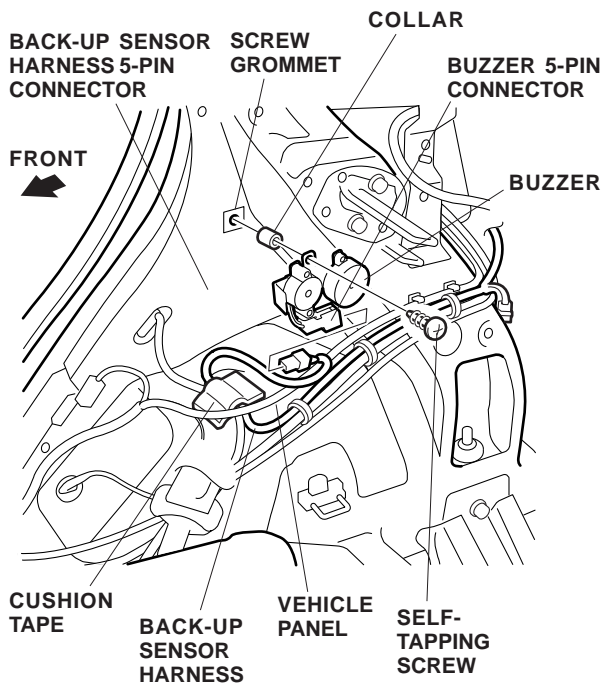

34. Plug the back-up sensor harness 5-pin connector into the buzzer 5-pin connector and secure the buzzer to the screw grommet with the self-tapping screw and collar.

35. Route the back-up sensor harness up along the vehicle harness, and secure it to the vehicle harness with five wire ties. Don't secure the back-up sensor harness to the SRS harness.

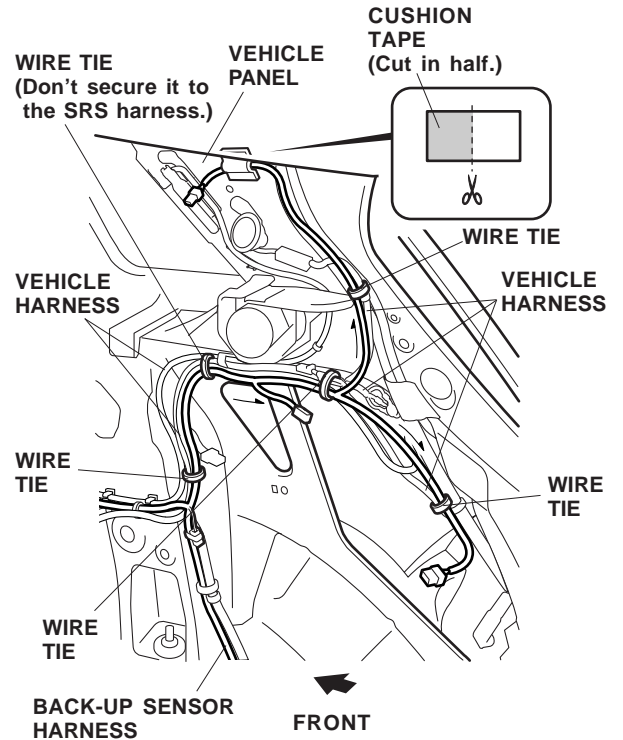

36. Using isopropyl alcohol, thoroughly clean the vehicle panel area where the cushion tape will attach. Using scissors, cut one cushion tape in half. Secure the back-up sensor harness to the vehicle panel with half of a cushion tape.

37. Attach the (2A) fuse label to the back-up sensor harness fuse case.

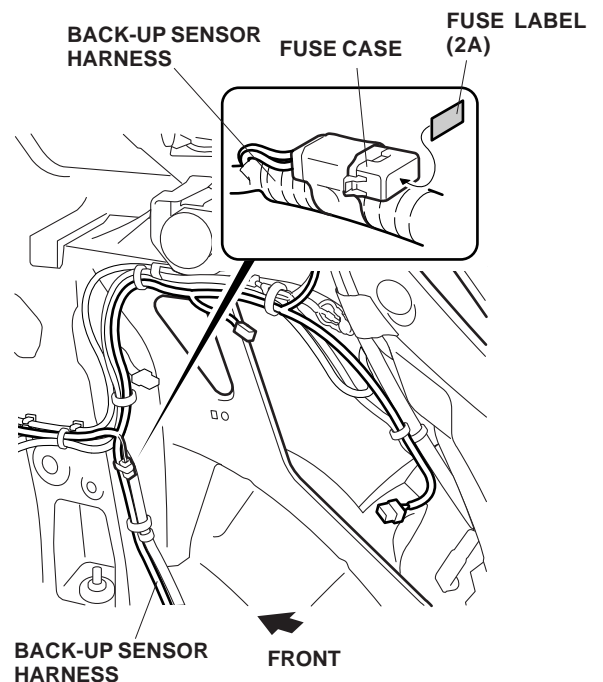

38. Plug the back-up sensor harness 2-pin connector into the vehicle 2-pin connector.

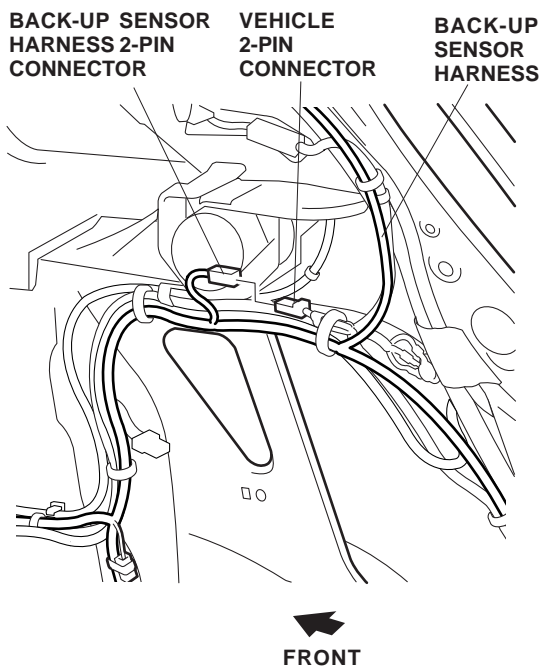

39. Insert the control unit bracket into the control unit in the direction shown.

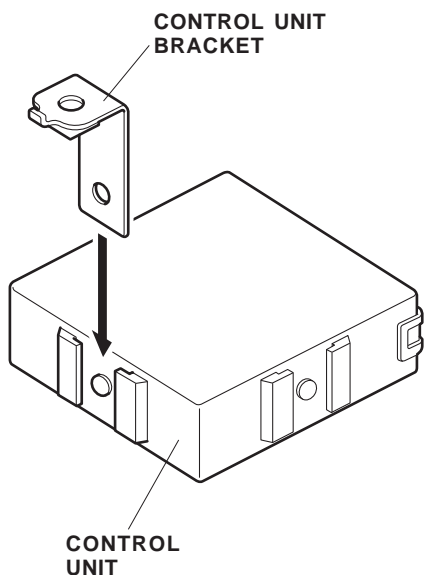

40. Plug the back-up sensor harness 14-pin connector into the control unit and install the control unit bracket to the vehicle panel with the special screw.

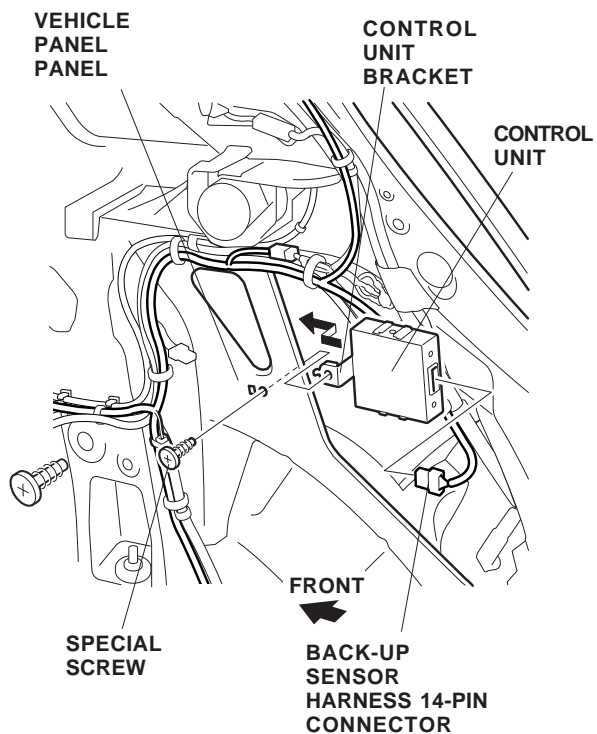

41. Get the right quarter panel trim, and locate the preset. Using a pushpin, pierce at the center of the preset.

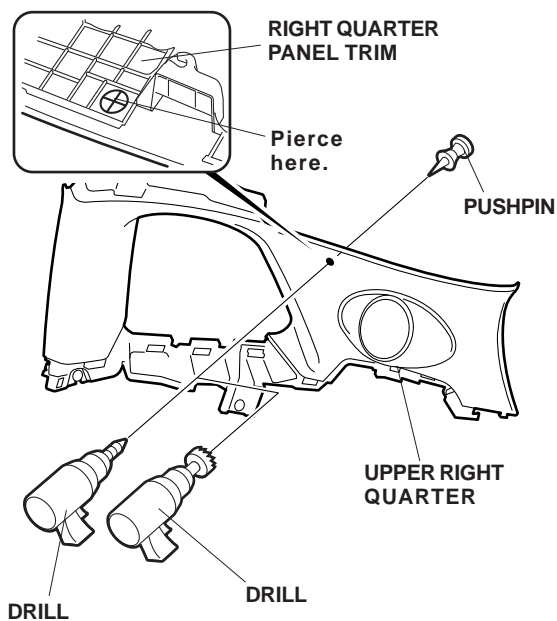

42. While wearing eye protection, drill a 19 mm hole at the pierced point from the outside surface of the right quarter pillar trim. Remove all burrs.

43. Route the back-up sensor harness 4-pin connector into the 19 mm hole, and reinstall the right quarter pillar trim.

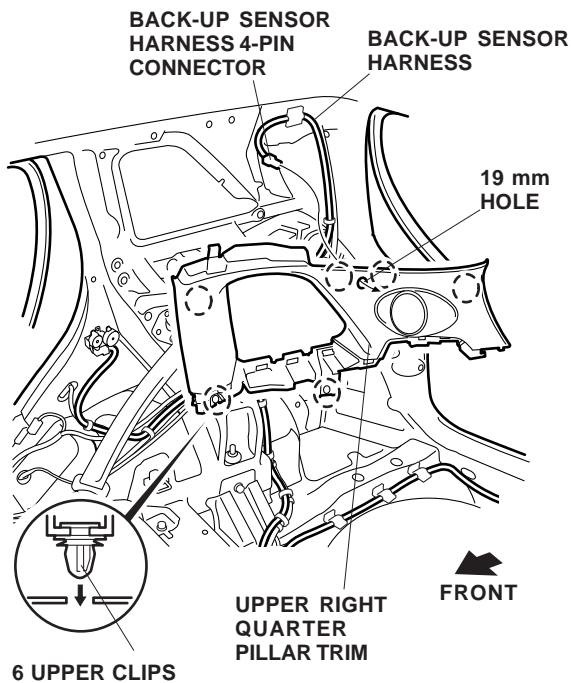

44. Plug the back-up sensor harness 4-pin connector into the switch, and install the switch into the 19 mm hole in the direction shown.

(Switch Installation Direction)

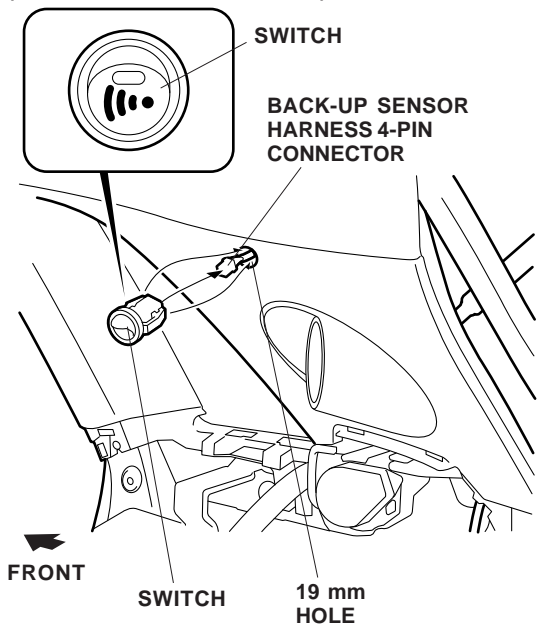

45. Reinstall the speaker.

46. Route the back-up sensor harness along the rear bumper beam.

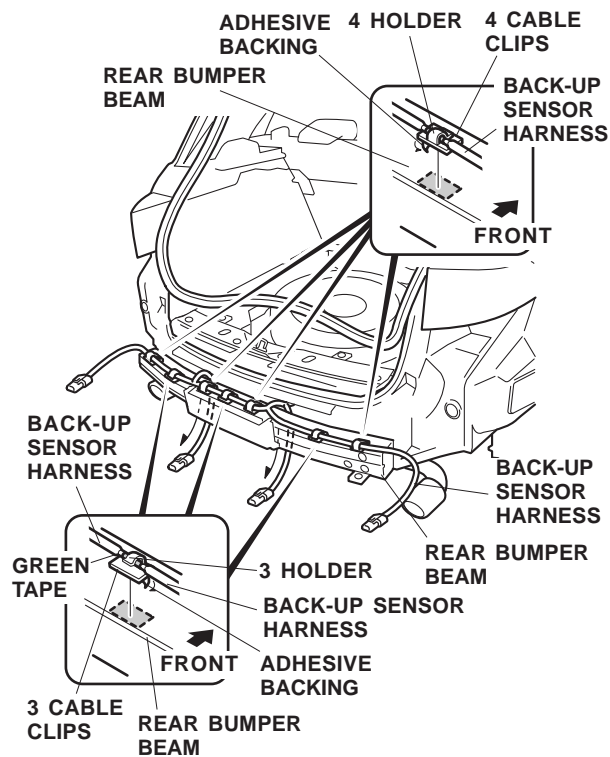

47. Attach the seven harness clips to the back-up sensor harness. Three of the clips attach at the green-taped locations. Using isopropyl alcohol on a shop towel, clean the rear bumper beam where the harness clips attaches. Remove the adhesive backings from the seven harness clips, and attach them to the rear bumper beam in the area shown. Start at the center and work your way outward on each side.
48. With an assistant holding the rear bumper near the vehicle, plug in the four back-up sensor harness 2-pin connectors.

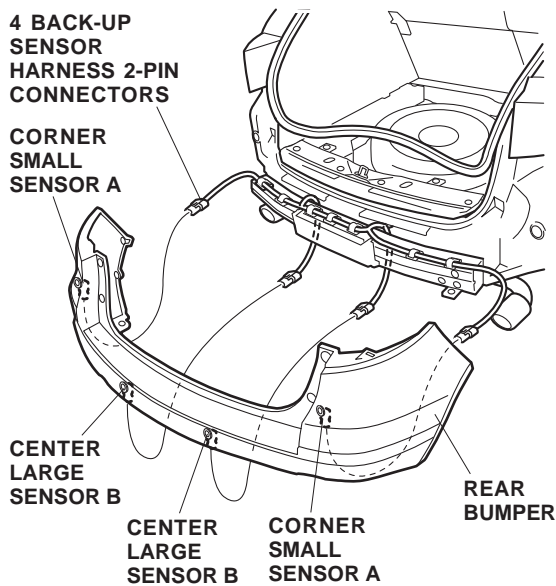

49. Check that all wire harnesses and cables are routed properly and that all connectors are plugged in.
50. Reinstall all removed parts.
51. Reconnect the negative cable to the battery.
52. Enter the anti-theft codes for the radio and navigation systems, then enter the client's radio presets.
53. Check that the back-up sensors work properly as described in the accessory user's information manual.
54. Reset the driver's window AUTO UP/DOWN function:
  - Start the engine. Push down on the driver's window switch until the window is fully open.
  - Pull on the driver's window switch to close the window completely, then hold the switch to close the window completely, then hold the switch for 1 second or more.
  - Lower and raise the driver's window to check operation of the AUTO UP/DOWN function.