



INSTALLATION INSTRUCTIONS

Accessory
CARGO HOOKS
P/N 08L96-TK4-200

Application
2009 TL

Publications No.
BII 39484
Issue Date
SEP 2008

PARTS LIST

2 Cargo hooks



2 Cargo hook brackets



2 Rivet nuts, 6 mm



2 Plain washers



2 Spring washers



2 Bolts



TOOLS AND SUPPLIES REQUIRED

- Drill
- 10 mm Drill bit
- Scale
- Electrical tape
- Eye protection (face shield, safety goggles, etc.)
- Utility knife
- Rivet Nut Tool (P/N 07AAE-000A100)
- Hex wrench
- 19 mm Wrench
- 10 mm Socket
- Torque wrench
- Blanket
- Touch-up paint
- File
- Plastic Trim Tool (T/N SILTRIMTL10)

INSTALLATION

Client Information: The information in this installation instruction is intended for use only by skilled technicians who have the proper tools, equipment, and training to correctly and safely add equipment to your vehicle. These procedures should not be attempted by “do-it-yourselfers.”

NOTE: These instructions show the left side cargo hook being installed. The same procedure applies to installing the right side cargo hook.

Installing the Cargo Hook

1. Open the trunk lid. Pull down the trunk upper trim panel (four clips).

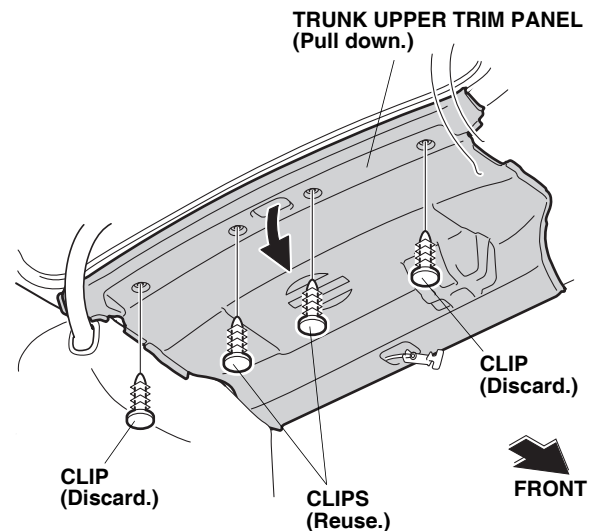

2. Locate the hole in the rear metal shelf where the cargo hook will attach.

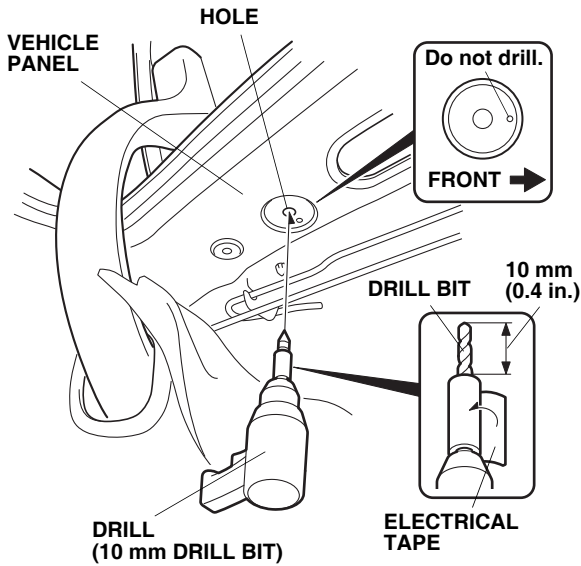

3. While wearing eye protection, enlarge the hole in the rear metal shelf to 10 mm.
- To prevent metal shavings from falling onto the trunk floor, place a blanket over the trunk floor.
 - Take care not to damage the wire harness when drilling.
 - Wrap each drill bit with ten layers of electrical tape 10 mm (0.4 in.) from the tip, or use a drill stop. Do not drill deeper than 10 mm.
 - Remove all burrs and metal shavings, and apply touch-up paint to the edges of each drilled hole. Allow the touch-up paint to dry before proceeding to the next step.

4. Thread the 6 mm rivet nut onto the mandrel of the rivet nut tool as shown.

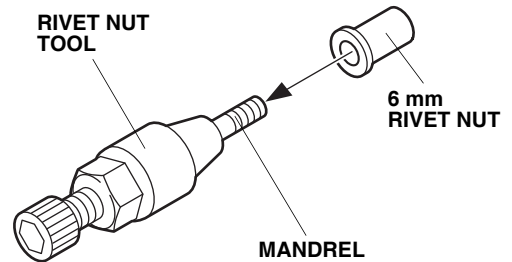

5. Insert the 6 mm rivet nut into the hole in the vehicle panel, and attach the hex wrench to the rivet nut tool.

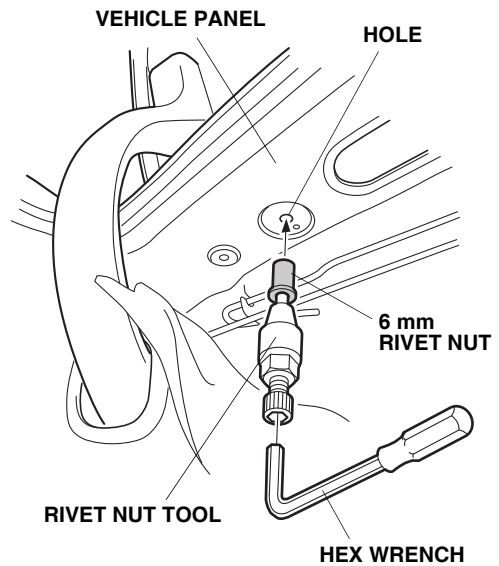

6. Holding the rivet nut tool with the hex wrench, and turn the 19 mm wrench counterclockwise to install the 6 mm rivet nut to the vehicle panel.

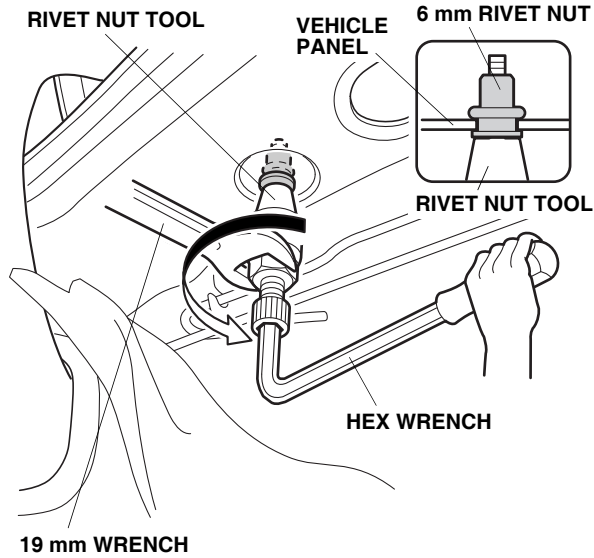

7. Remove the rivet nut tool from the 6 mm rivet nut by turning the hex wrench counterclockwise.
8. Using a utility knife, cut out the trunk upper trim panel in the area shown.

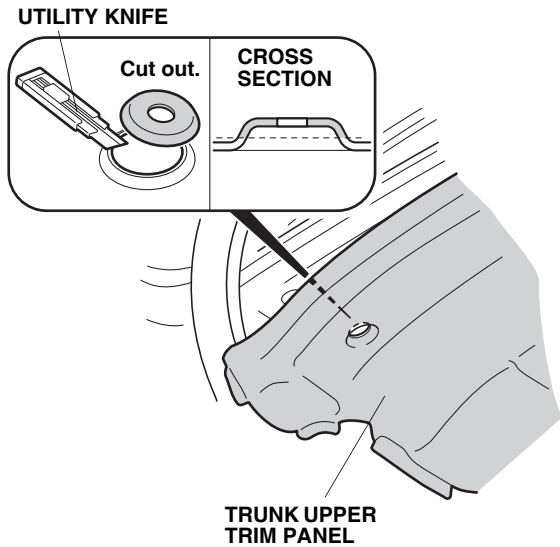

9. Make sure that the cargo hook bracket can be inserted into the hole in the trunk upper trim panel. If necessary, enlarge the hole in the trunk upper trim panel.

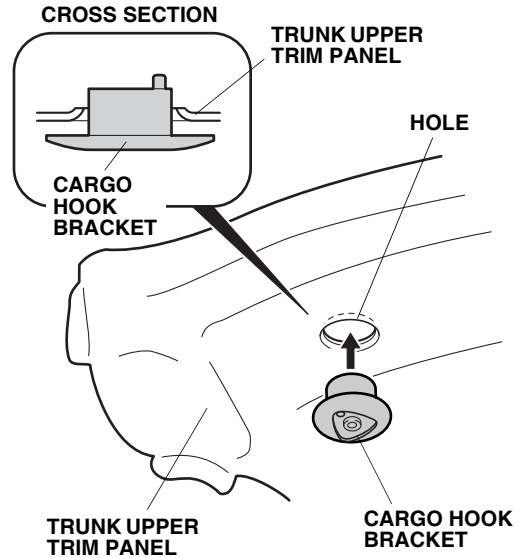

10. Repeat steps 2 through 9 to install a rivet nut, and to cut the trim panel the other side of the vehicle.
11. Reinstall the trunk upper trim panel with two clips.

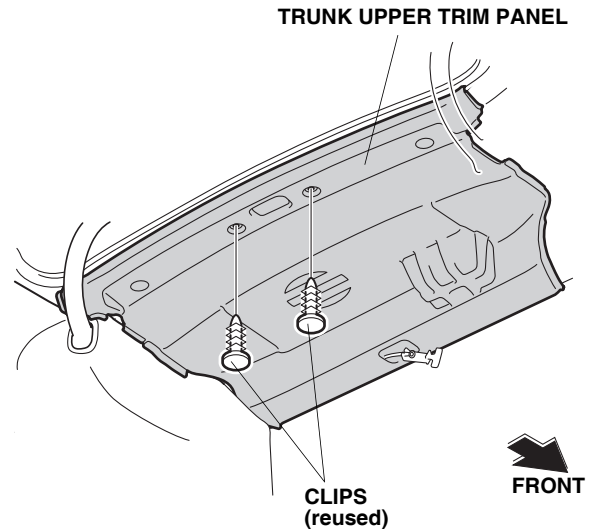

- Align the cargo hook pin with the hole in the cargo hook bracket.

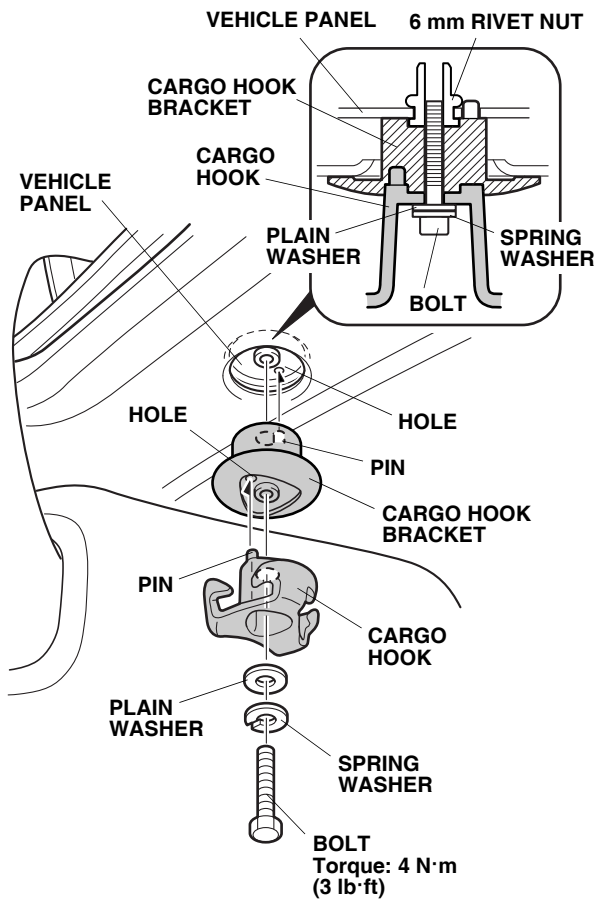

- Align the cargo hook bracket pin with the hole in the vehicle panel, and install the cargo hook and cargo hook bracket to the vehicle panel using one bolt, one plain washer, and one spring washer. Torque the bolt to 4 N·m (3 lb·ft).
- Repeat steps 12 and 13 to install a cargo hook on the other side of the vehicle.