



INSTALLATION INSTRUCTIONS

Accessory
BACKUP SENSORS

Application
2009 RL

Publications No.
BII 39752
Issue Date
JUNE 2008

PARTS LIST

Backup Sensor Attachment Kit P/N 08V67-SJA-200J

Control unit

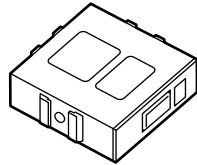

Buzzer

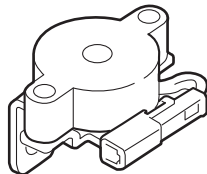

Main harness

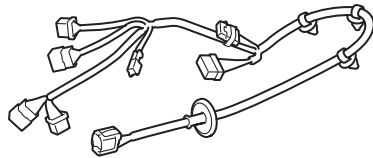

Bracket A

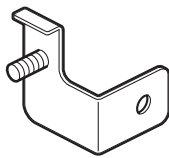

Bracket B

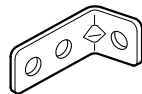

13 Wire ties

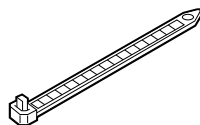

Urethane tape

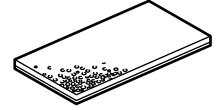

Washer-nut



Fuse label



Subharness

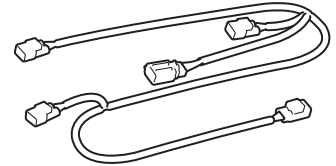

4 Aluminum tapes



2 Sensor clips A (Black)



2 Sensor clips B (White)

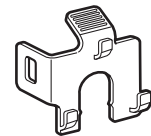

Wire tie with clip

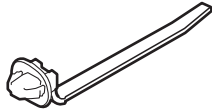

Holder

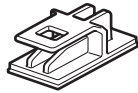

Self-tapping screw



Washer



Buzzer harness

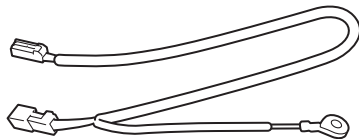

Ground bolt

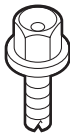

Accessory User's Information Manual

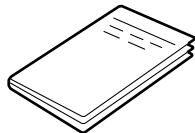

**Backup Sensor Kit
P/N 08V67-SJA-200F**

2 Center sensors (large)

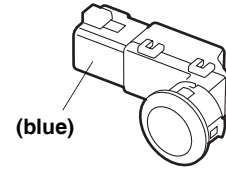

2 Corner sensors (small)

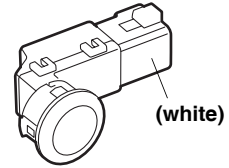

TOOLS AND SUPPLIES REQUIRED

- Phillips screwdriver
- Flat-tip screwdriver
- Small flat-tip screwdriver
- Ratchet
- 8 mm and 10 mm Sockets
- Torque wrench
- Pushpin
- Drill
- 3 mm Drill bit
- 24 mm and 26 mm Hole saw
- Masking tape
- Tape measure (metric)
- Eye protection (safety goggles, face shield, etc.)
- 10 mm Combination wrench
- Blanket or Cardboard
- File
- Diagonal cutters
- Isopropyl alcohol
- Shop towel
- Scissors

Illustration of the Backup Sensors Installed on the Vehicle

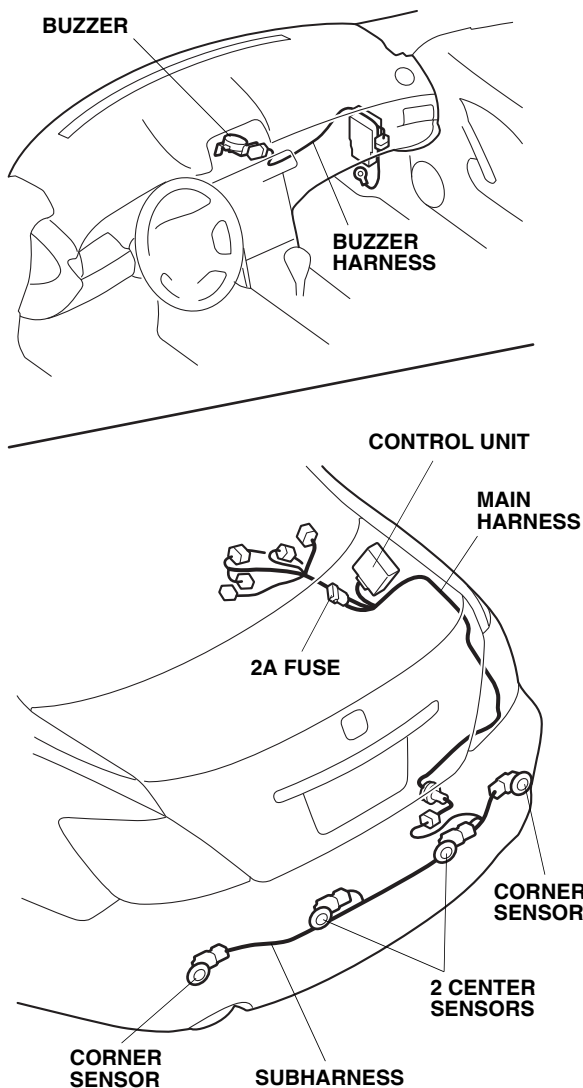

INSTALLATION

Client Information: The information in this installation instruction is intended for use only by skilled technicians who have the proper tools, equipment, and training to correctly and safely add equipment to your vehicle. These procedures should not be attempted by “do-it-yourselfers.”

1. Make sure you have the anti-theft code for the radio and navigation system, then write down the radio presets.
2. Disconnect the negative cable from the battery.

Installing the Sensors

3. Open the trunk lid, remove the two caps.
4. Remove the two bolts, two self-tapping screws, four screws, and two clips that secure the rear bumper.
5. Remove the rear bumper.
 - Have an assistant help you when removing and installing the bumper.
 - To prevent damage to the bumper, set it on a cardboard or a blanket.

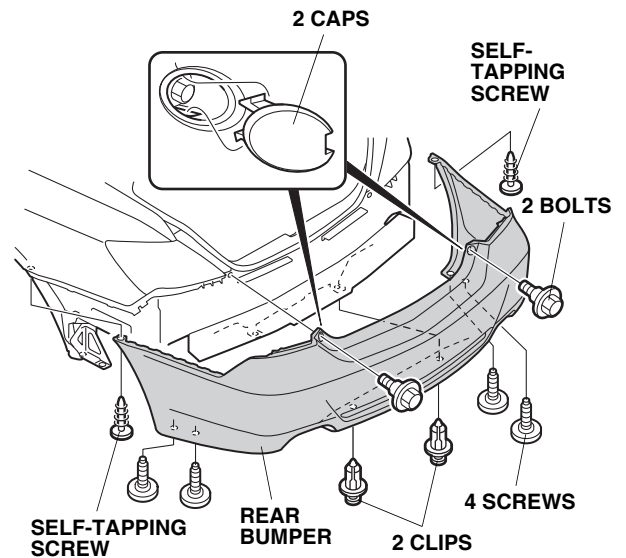

- Using a pushpin, pierce the rear bumper at the eight points shown. There are several markings on the reverse of the rear bumper; make certain that you locate the proper cross marks.

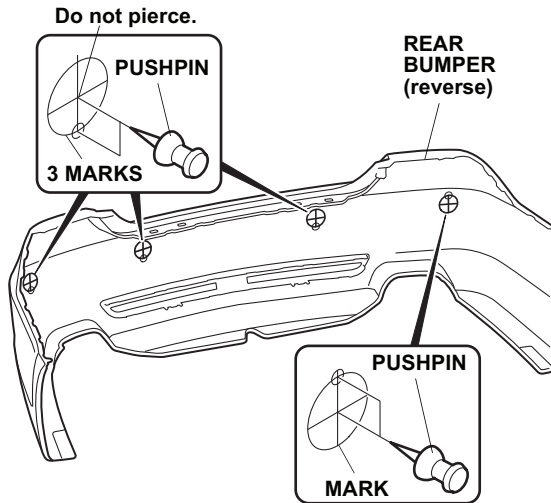

- While wearing eye protection, make four 3 mm holes through the four marks shown on the rear bumper.
- Enlarge the two 3 mm holes shown to 24 mm holes.
- Remove any burrs from the edge of the holes.

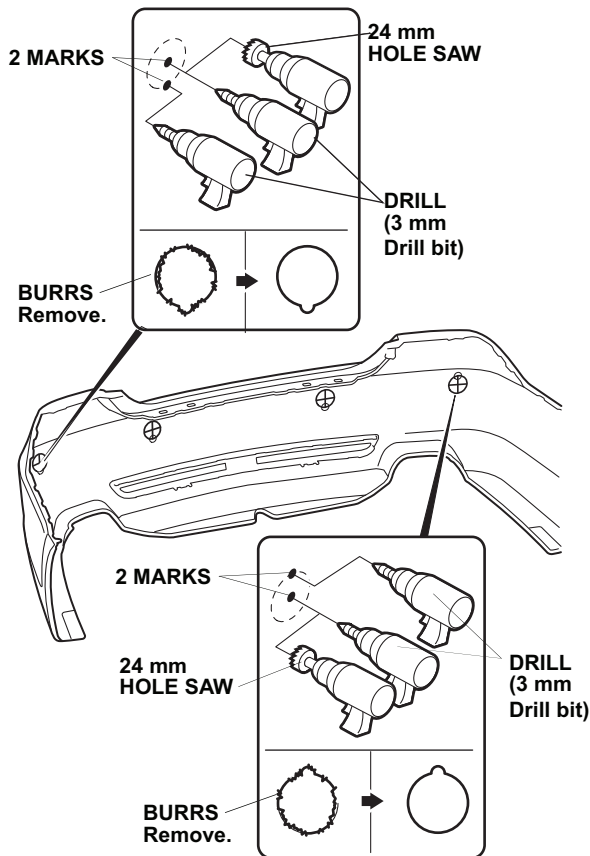

- Make four 3 mm holes through the four marks shown on the rear bumper.
- Enlarge the two 3 mm holes shown to 26 mm holes.
- Remove any burrs from the edge of the holes.

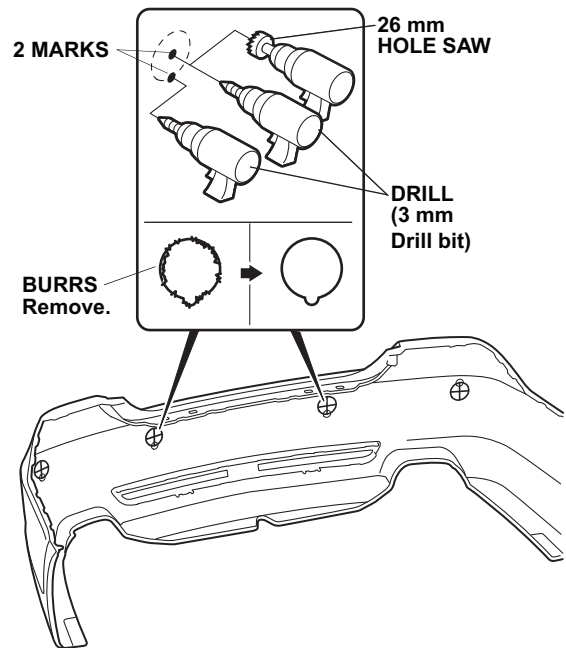

- Install the one corner sensor (white) in the rear bumper using one sensor clip A.

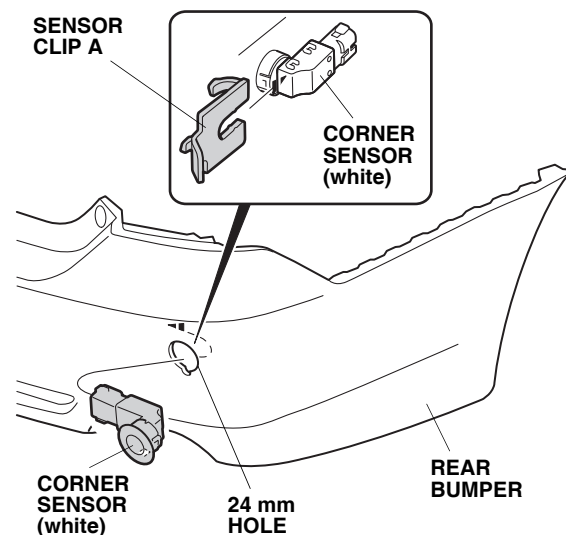

14. Install the one corner sensor (white) in the rear bumper using one sensor clip A.

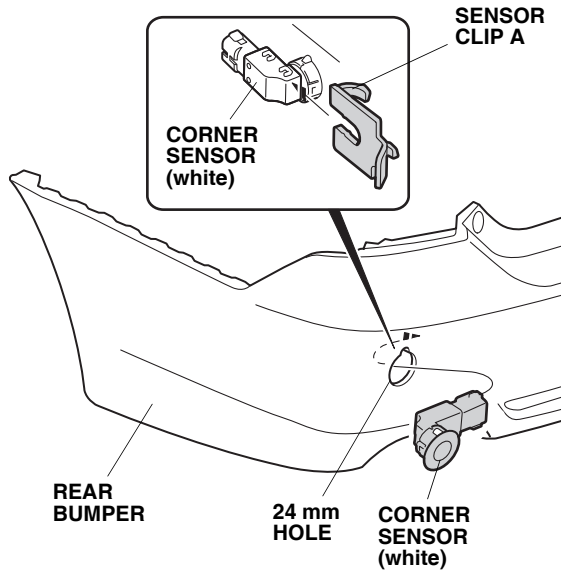

15. Install the two center sensors (blue) in the rear bumper using two sensor clips B.

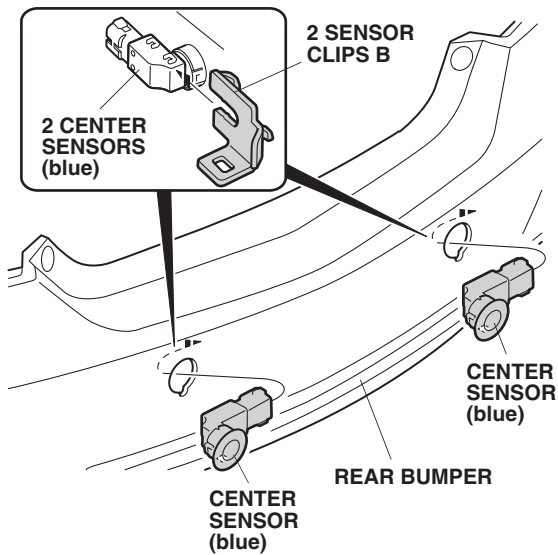

16. Plug the four subharness 2-pin connectors to the two corner sensors and two center sensors.

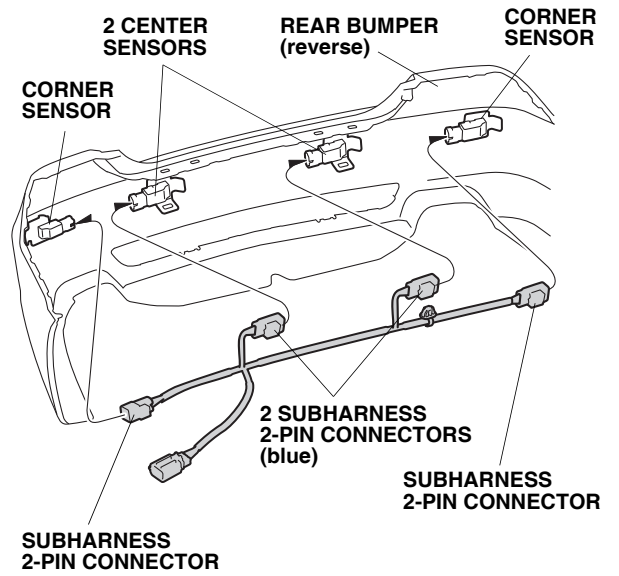

17. Using one wire tie with clip, secure the subharness to the sensor clip B as shown.
18. Install the subharness clip to the sensor clip B as shown.

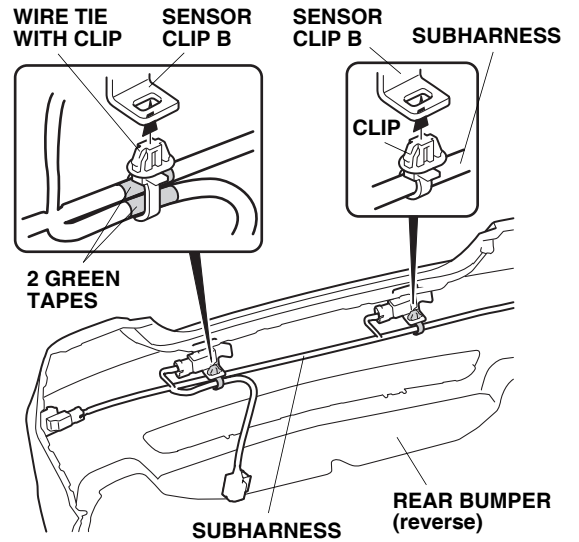

19. Using isopropyl alcohol on a shop towel, thoroughly clean the areas where aluminum tapes will attach.
20. Using four aluminum tapes, secure the subharness to the rear bumper as shown.

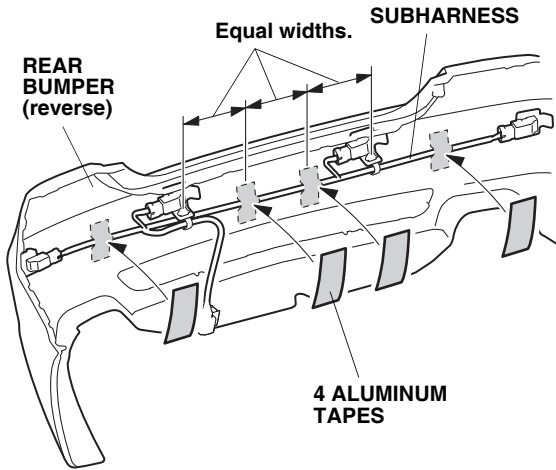

Routing the Main Harness

21. Remove the spare tire lid.

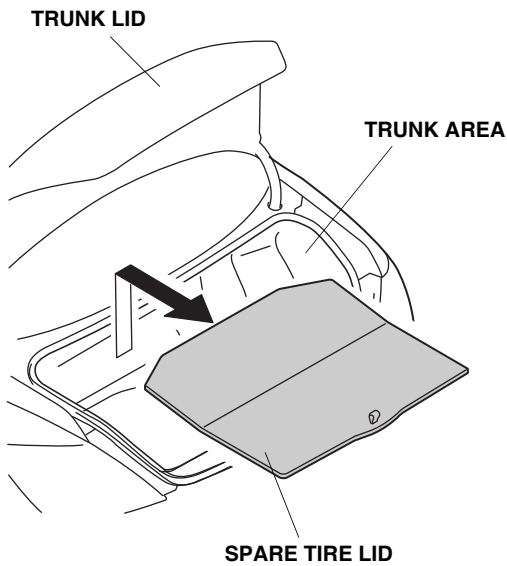

22. Pull away the weatherstrip in the area shown, and remove the rear trim panel (four clips and three retaining tabs).

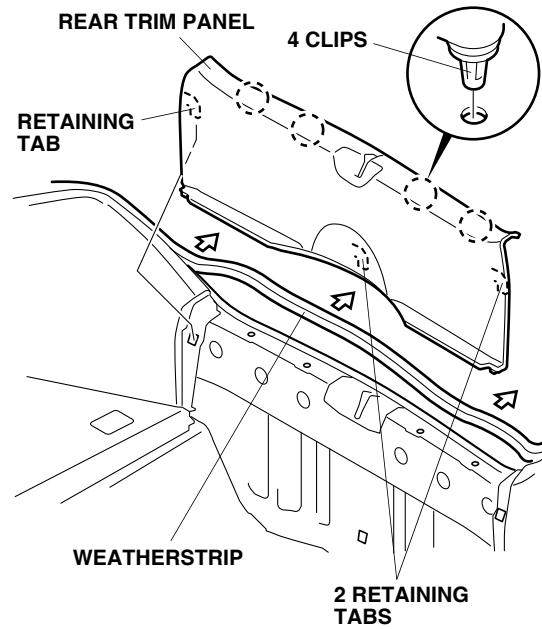

23. Remove the trunk hook (one clip). Open the covers and remove one screw and one tie-down hook from each.
 - Insert a small flat-tip screwdriver at the edge of the tie-down hook cover and pry it open.
 - Take care not to damage the tie-down hook cover when opening it.

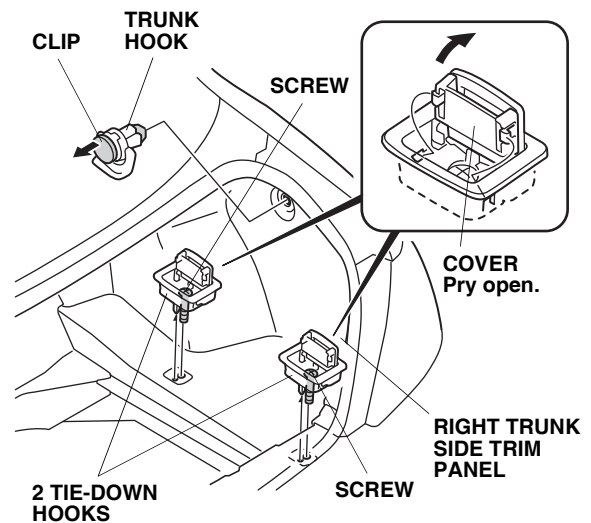

24. Remove the right weatherstrip in the area shown. Remove one clip, and turn up the trunk front trim panel (one clip.)
25. Remove the right trunk side trim panel (two clips.)

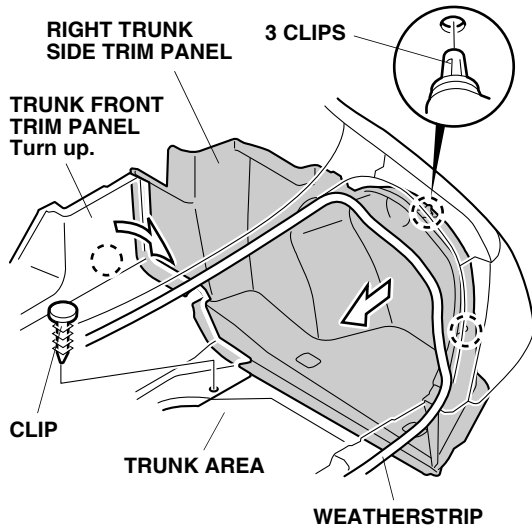

26. Attach the fuse label (2A REAR SENSOR) to the main harness fuse case.
27. WITH REAR CAMERA: Using one wire tie, secure the urethaned 6-pin connector to the subharness. Wrap one urethane tape around the 6-pin connector.
28. WITHOUT REAR CAMERA: Using one wire tie, secure the urethaned 20-pin connector to the subharness. Wrap one urethane tape around the 20-pin connector.

WITH REAR CAMERA

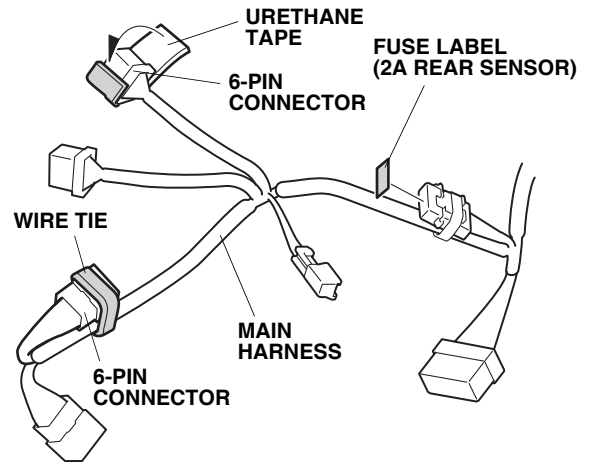

WITHOUT REAR CAMERA

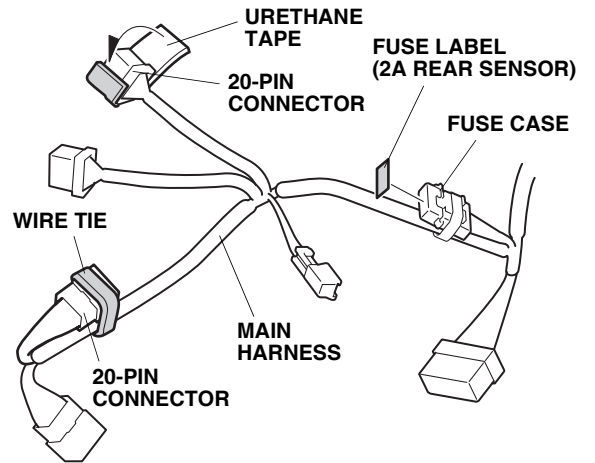

29. Set the washer-nut onto bracket A, and install bracket A onto the control unit.
30. Plug the main harness 14-pin connector into the control unit.

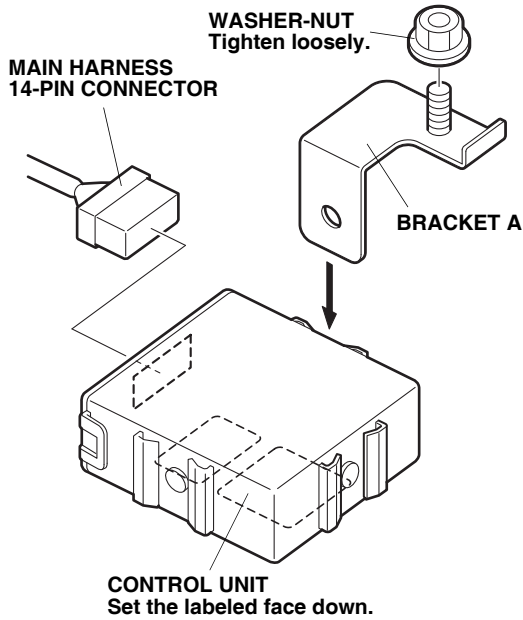

31. Install the control unit to the vehicle panel and tighten the washer-nut.

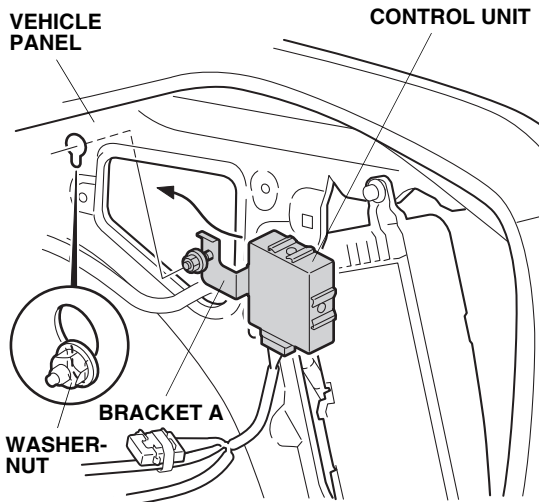

32. Unplug the vehicle 20-pin/6-pin connectors shown.
33. Plug the two main harness 20-pin/6-pin connectors to the vehicle 20-pin/6-pin connectors as shown.

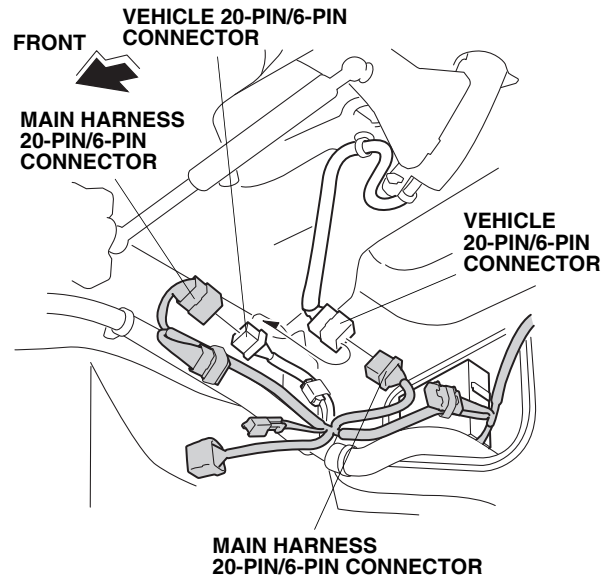

34. Remove the blue tape securing the vehicle 2-pin connector, then plug the vehicle 2-pin connector to the main harness 2-pin connector.

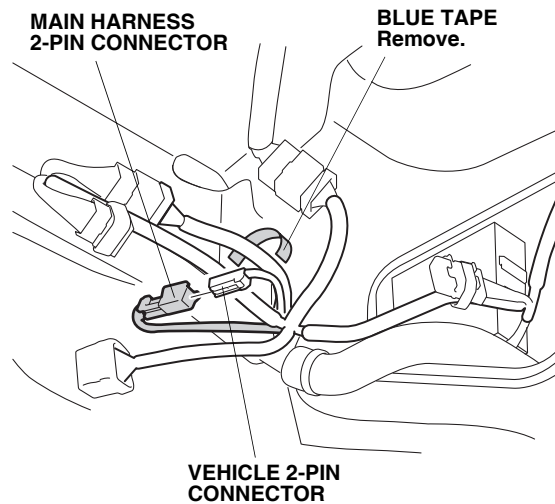

35. Using four wire ties, secure the main harness to the vehicle harness in the areas shown.

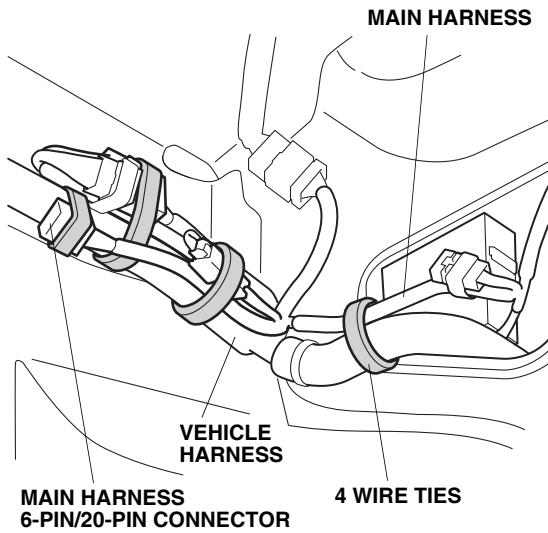

36. Insert the two main harness clips to the vehicle panel shown to secure the main harness.

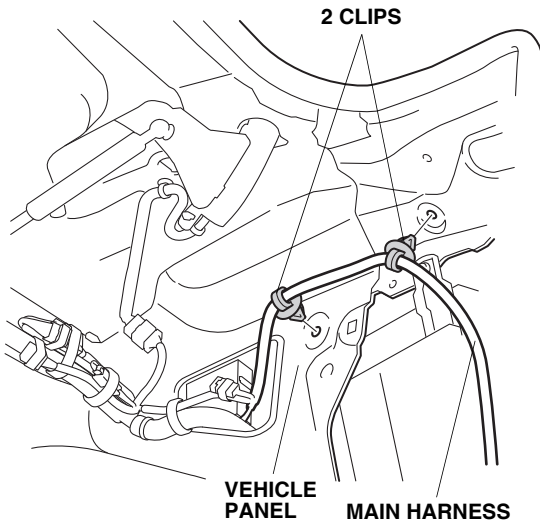

37. Remove the nut from the vehicle panel, install bracket B, and tighten it with the removed nut. Route the main harness to the rear side of the vehicle.
38. Insert the main harness clip into bracket B.

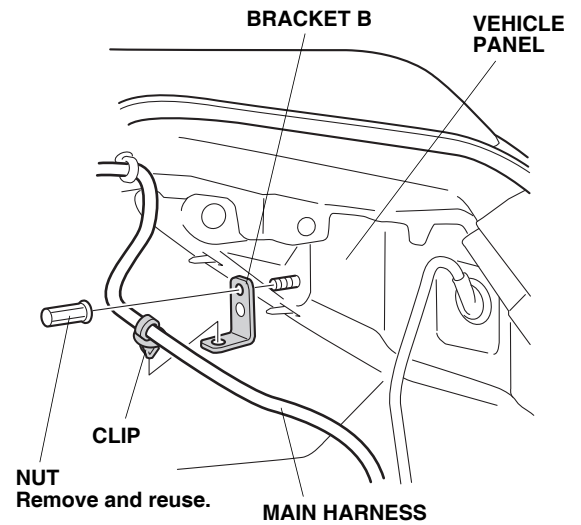

39. Inside the trunk, push the one grommet out and discard.
40. Route the main harness as shown, set the main harness grommet to the vehicle panel.

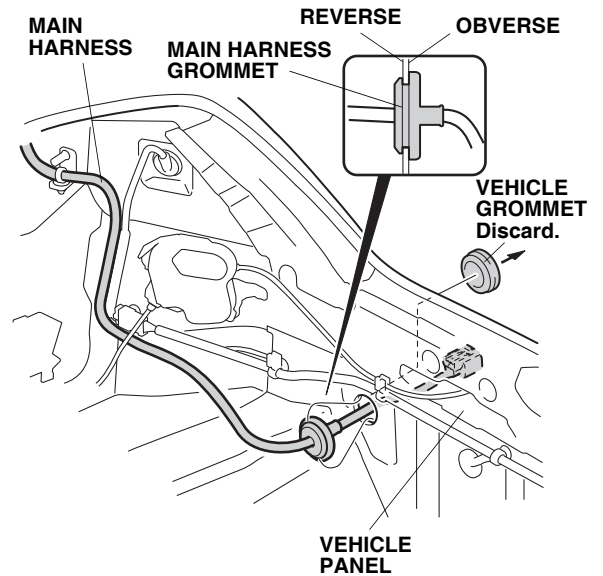

41. Using four wire ties, secure the main harness to the vehicle harness in the areas shown.

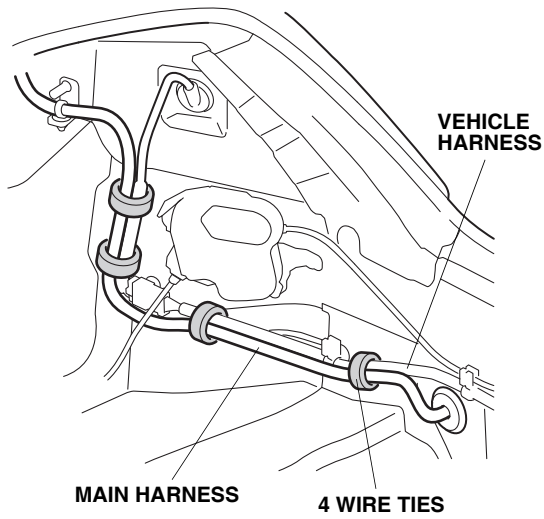

42. Using isopropyl alcohol, thoroughly clean the area where the holder will attach.
43. Attach a holder to the rear bumper beam as shown, then set the main harness 8-pin connector in the holder.

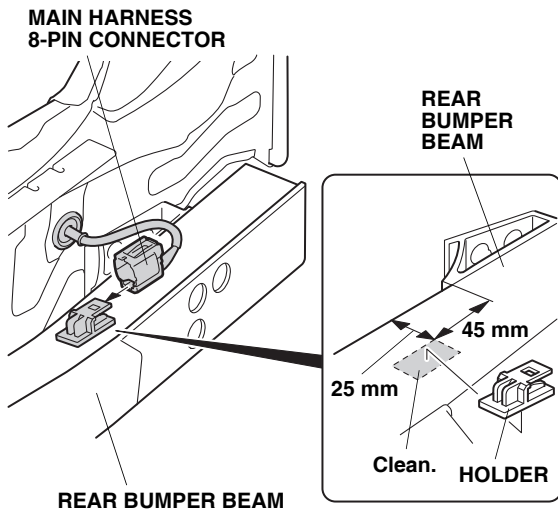

44. Plug the subharness 8-pin connector to the main harness 8-pin connector, then reinstall the rear bumper.

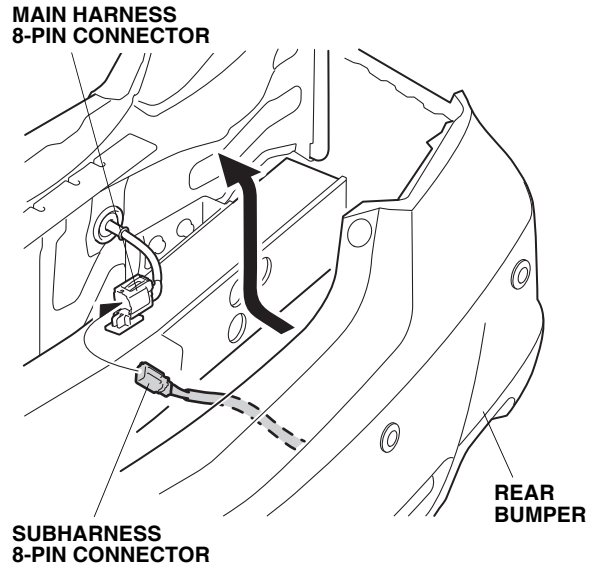

Installing the Buzzer

45. Release the three clips and two pins, then unplug the vehicle connector to remove the passenger's under cover.

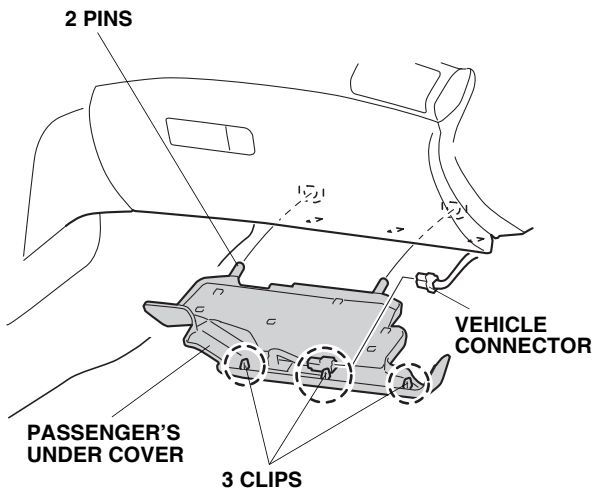

46. Remove the right front side step trim (two retaining tabs, two hooks, and four clips).

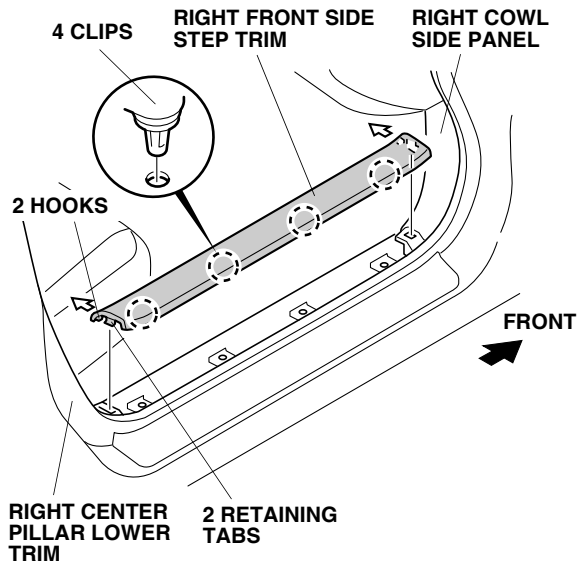

47. Pull away the right front door opening seal. Remove the right cowl side panel (two clips).

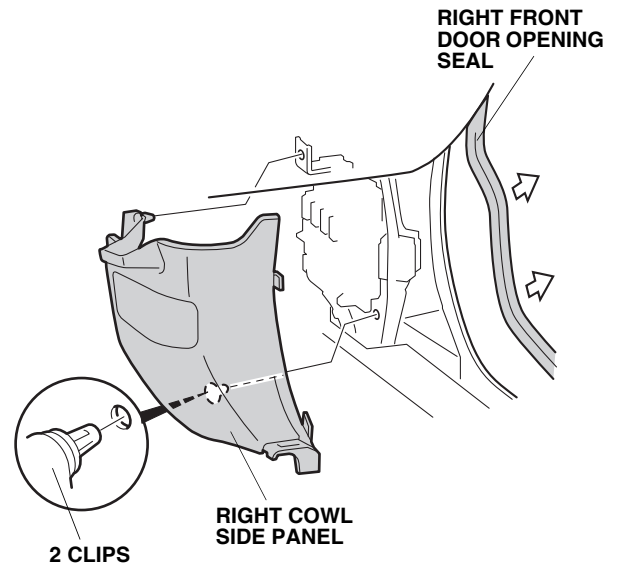

48. Remove the tape securing the vehicle 4-pin connector.
49. Plug the buzzer harness 4-pin connector to the vehicle 4-pin connector.
50. Using the ground bolt, secure the buzzer harness terminal to the vehicle panel.

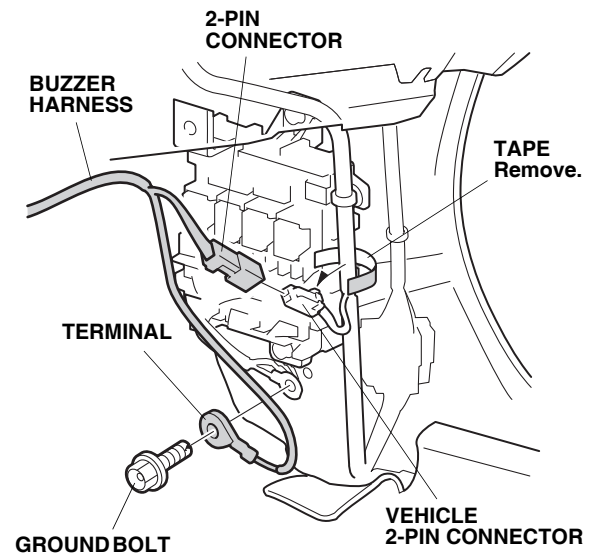

51. Route the buzzer harness as shown.
52. Using three wire ties, secure the buzzer harness to the vehicle harness in the areas shown.

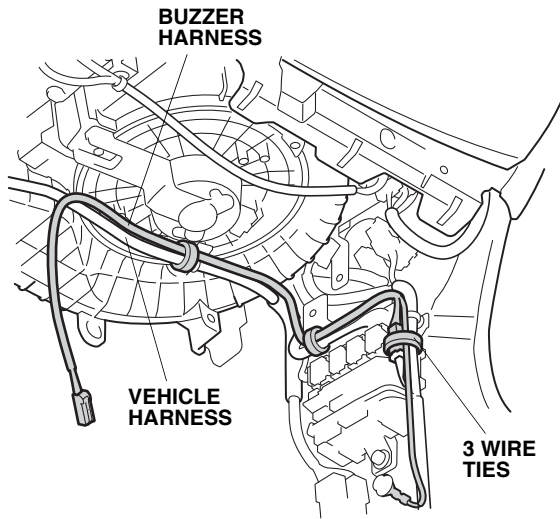

53. Using a self-tapping screw and a washer, install the buzzer as shown.

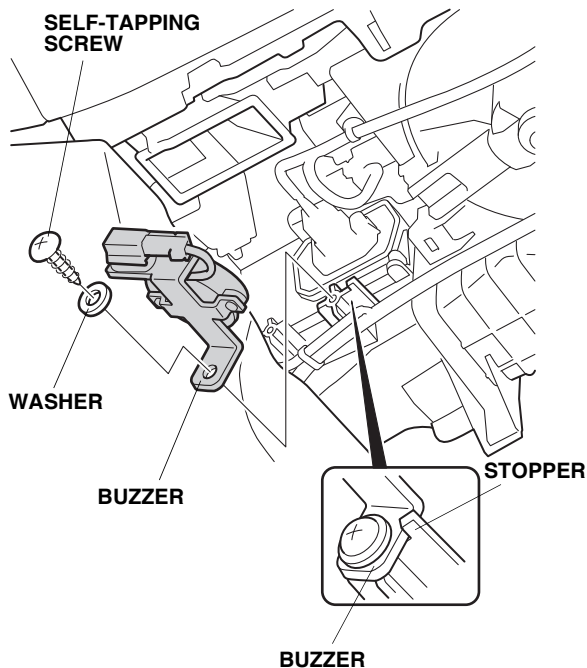

54. Plug the buzzer harness 4-pin connector to the buzzer.
55. Using one wire tie, secure the buzzer harness to the vehicle harness in the area shown.

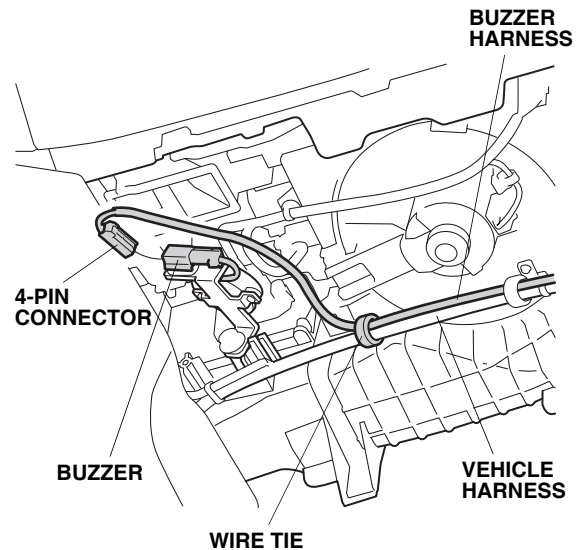

56. Check that all wire harnesses and cables are routed properly and that all connectors are plugged in.
57. Reinstall all removed parts.
58. Reconnect the negative cable to the battery.
59. Enter the anti-theft codes for the radio and navigation systems, then enter the customer's radio presets.
60. Reset the clock.
61. Check that the backup sensors work properly as described in the Accessory User's Information Manual, supplied with the backup sensor kit.

Buzzer Volume Control

The original setting of the volume control knob on the control unit is maximum. After checking the operation, turn the volume control knob to the appropriate volume.

