



INSTALLATION INSTRUCTIONS

Accessory
TRAILER HITCH

Application
2009 RDX

Publications No.
BII 39560
Issue Date
MAY 2008

PARTS LIST

**Trailer Hitch Kit
P/N 08L92-STK-200**

Trailer hitch

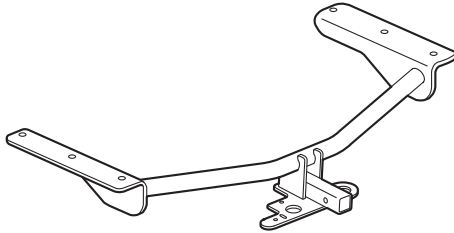

Ball mount

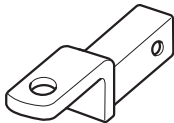

Right plate

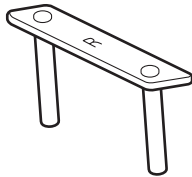

Left plate

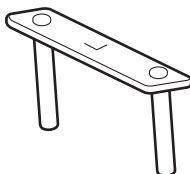

2 Hex bolts, 12 x 190 mm



2 Hex bolts, 12 x 175 mm



4 Hex nuts, 12 mm



10 Plain washers, 12 mm



6 Lock washers, 12 mm



2 Hex bolts, 12 x 40 mm

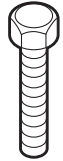

Hitch pin

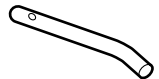

Hitch pin clip



Receiver cover

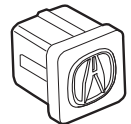

Template A
(For vehicles without a rear diffuser)

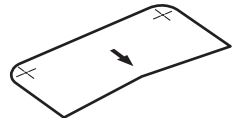

Template B
(For vehicles with a rear diffuser)

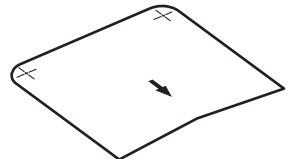

**Trailer Hitch Harness Kit
P/N 08L91-STK-200**

Trailer harness

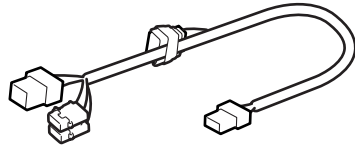

Trailer socket harness

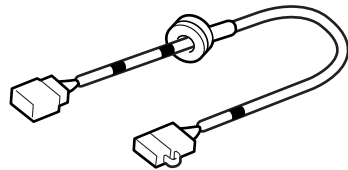

Control unit bracket

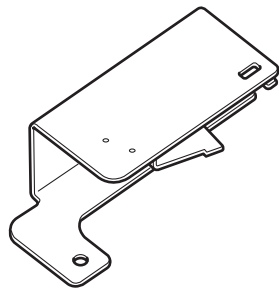

Control unit

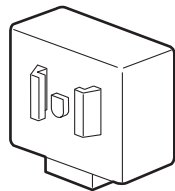

Connector bracket

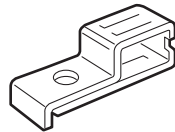

2 Flange bolts, 6 x 20 mm



Flange bolt, 6 x 16 mm

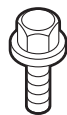

Flange nut, 6 mm



2 EPT sealers

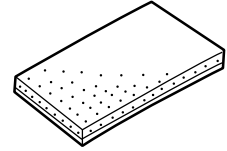

5 Wire ties

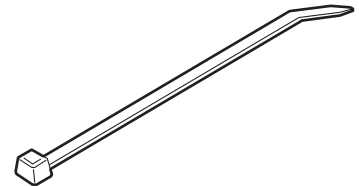

2 Wire ties with clips

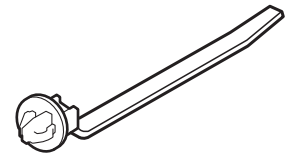

2 Connector clips



2 Jack nuts



Fuse label

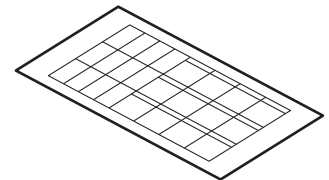

Accessory user's
information manual

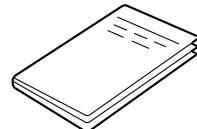
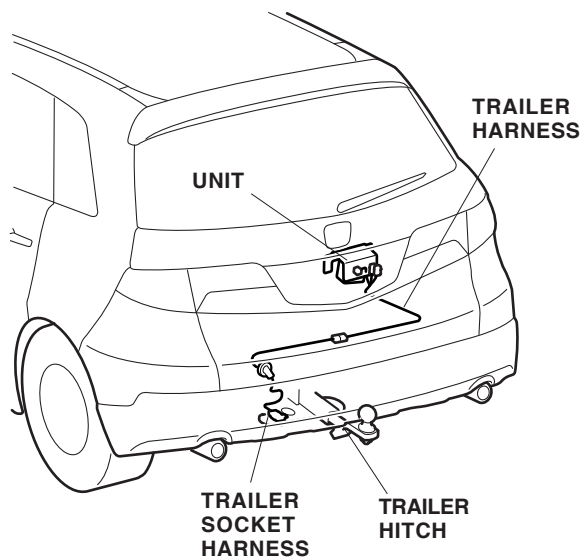

Illustration of the Trailer Hitch Installed on the Vehicle



TOOLS AND SUPPLIES REQUIRED

Phillips screwdriver
Flat-tip screwdriver
Ratchet
5 mm, 6 mm, 10 mm, 12 mm, and 19 mm Sockets
Utility knife
Tape measure
Clip remover
Diagonal cutters
Scissors
Torque wrench
Drill
3 mm and 10 mm Drill bits
Blanket
Eye protection (safety goggles, face shield, etc.)
Isopropyl alcohol
Shop towel
Saw blade
Felt-tip pen
Duct tape
Pushpin
14 mm Wrench

INSTALLATION

Client Information: The information in this installation instruction is intended for use only by skilled technicians who have the proper tools, equipment, and training to correctly and safely add equipment to your vehicle. These procedures should not be attempted by “do-it-yourselfers.”

NOTE:

- Be careful not to damage the rear bumper or other finished surfaces of the body.
 - Allow the exhaust system to cool down before installing the trailer hitch.
1. Make sure you have the anti-theft code for the radio, then write down the radio station presets.
 2. Disconnect the negative cable from the battery.
 3. Open the tailgate. Remove the cargo area cover.

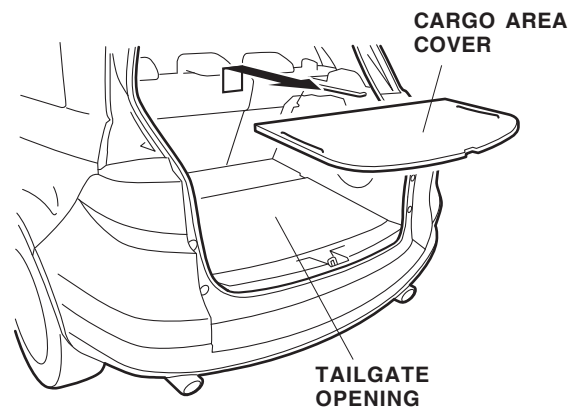

4. Remove the cargo area floor.

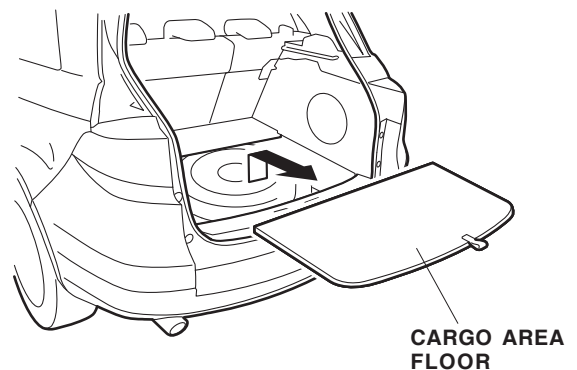

5. Remove the cargo area lid (four clips).

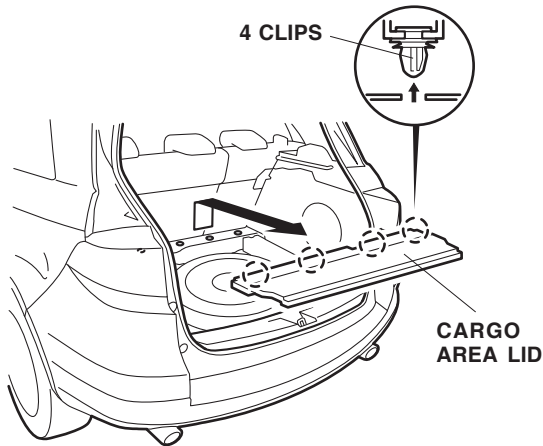

6. Remove the spare tire (one anchor bolt).

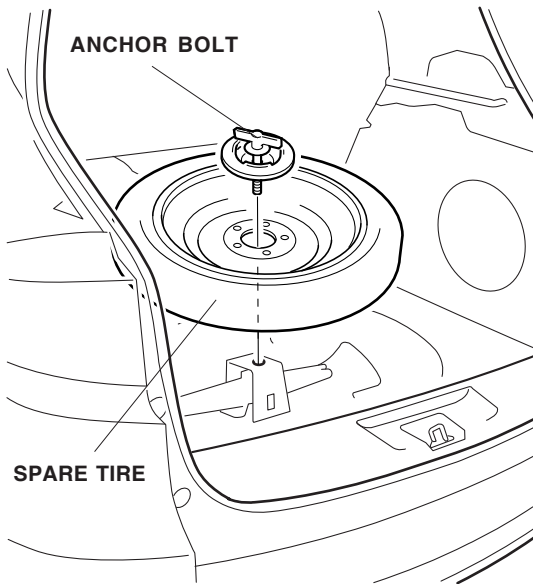

7. Locate the left spacer. Using a utility knife, cut out the left spacer in the area shown.

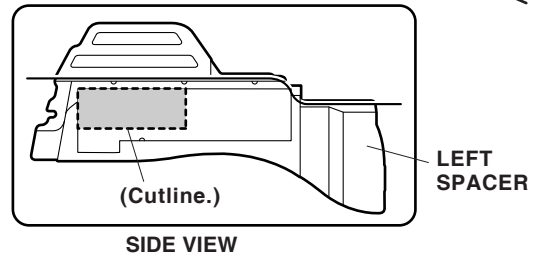
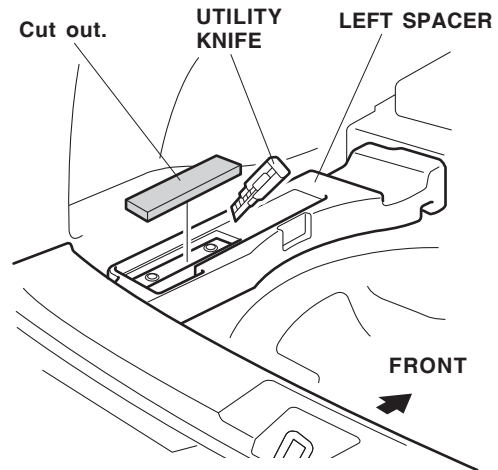

8. Locate the right spacer. Using a utility knife, cut out the right spacer in the area shown. Take care not to damage the vehicle harness under the right spacer.

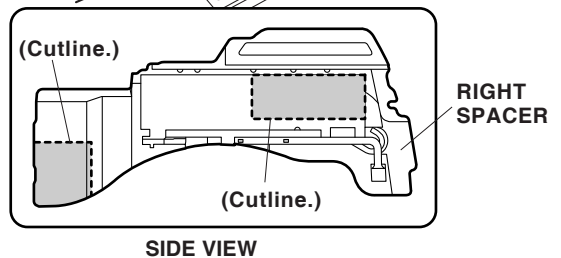
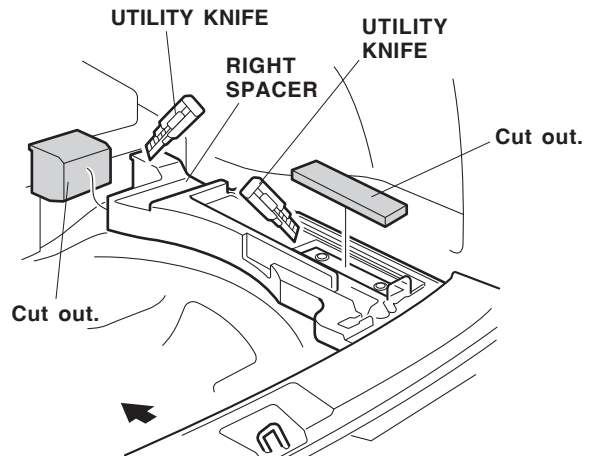

- Remove the two clips securing the right side trim panel and right floor spacer.

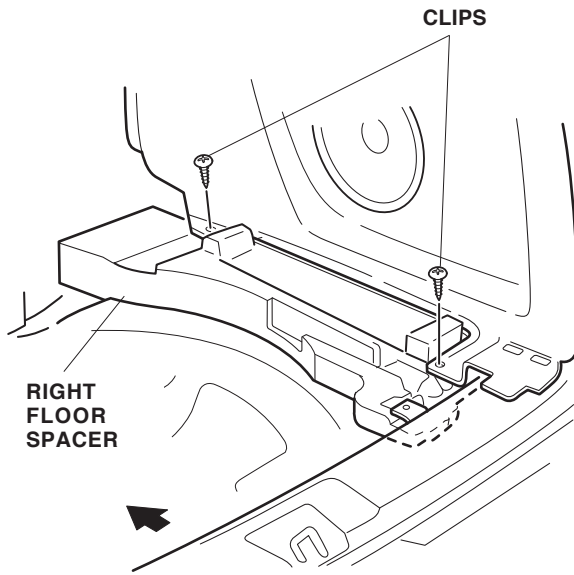

- Remove the right floor spacer by gently pushing in at the back edge, and pulling out at the front edge to clear the vehicle bracket.

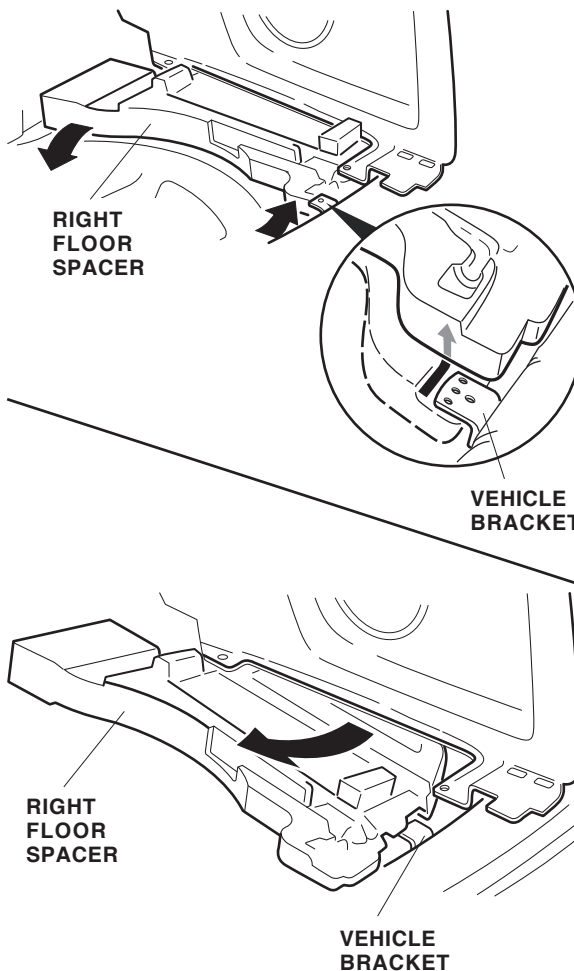

Routing the Hitch Harness

- Inside the vehicle along the rear panel, locate the rubber grommet. Remove the rubber grommet by pushing it outward.

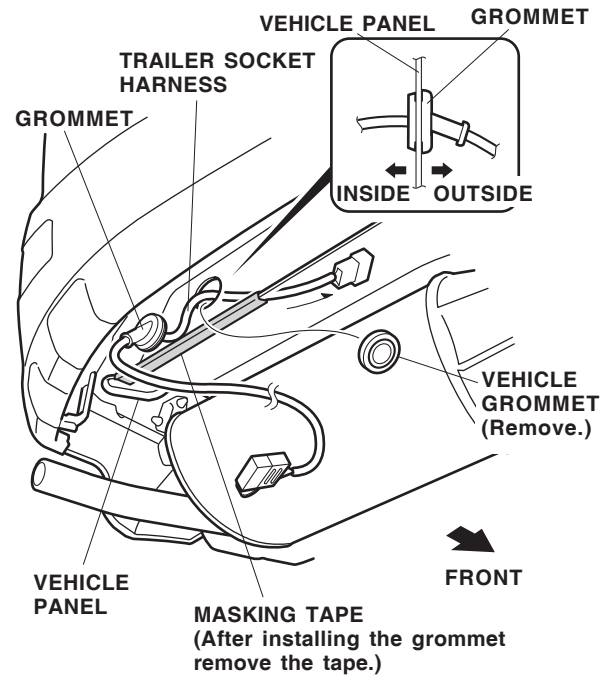
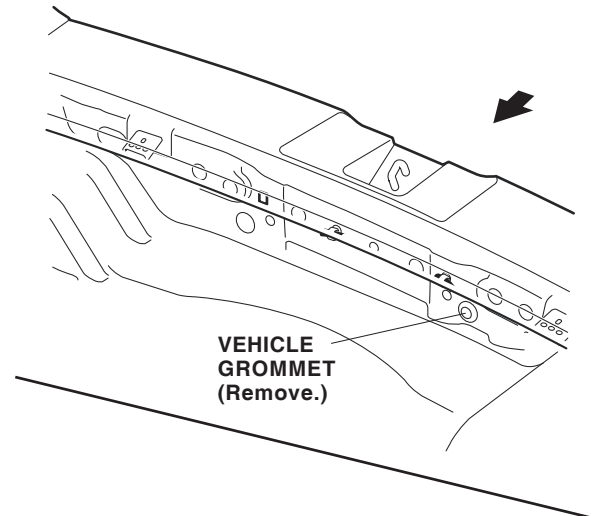

- Under the rear bumper, attach a piece of masking tape to the vehicle panel in the area shown.
- Get the trailer socket harness, and route the trailer socket harness inside of the vehicle. Seat the grommet in the panel hole in the direction shown.

- Install the two wire ties with clips at the green-taped area of the trailer socket harness, then secure the trailer socket harness to the vehicle panel.

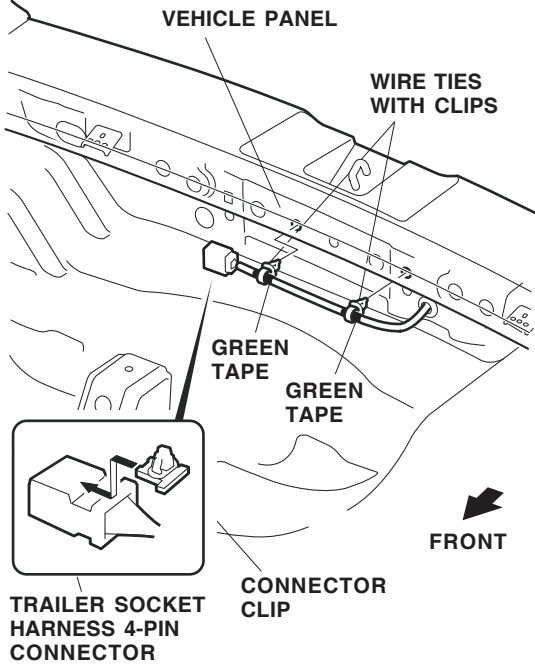

- Install the connector clip to the trailer socket harness 4-pin connector, but don't clip the connector at this time.
- Near the front of the cargo area, locate and remove the blue tape from the vehicle 6-pin connector. Plug in the hitch harness 6-pin connector into the vehicle 6-pin connector.

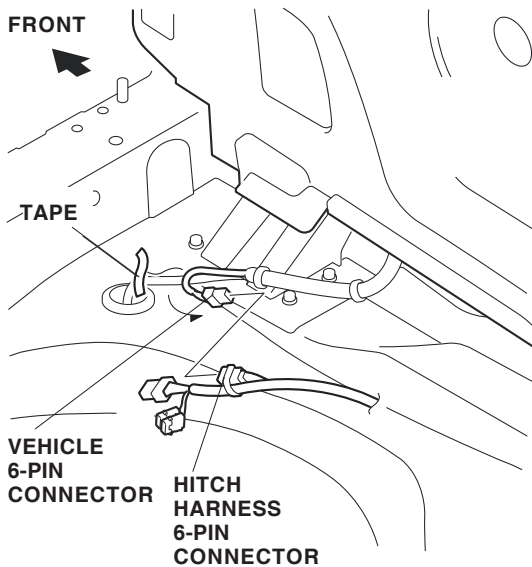

- Near the 6-pin connector, secure the hitch harness to the vehicle harness with two wire ties.

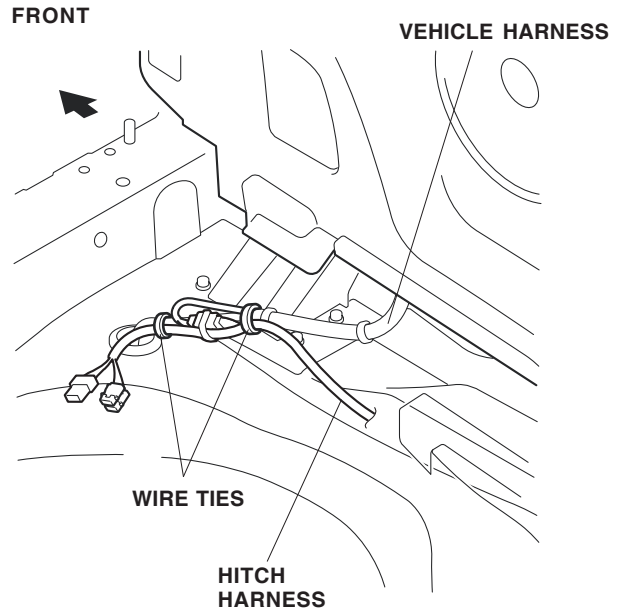

- Route the hitch harness towards the rear of the vehicle.
- Without Backup Sensors:** Using scissors, cut the two EPT sealers in half. Using isopropyl alcohol on a shop towel, clean the vehicle panel surface where the EPT sealer will attach. Secure the hitch harness to the vehicle using three halves of the EPT sealers. The remaining cut piece of EPT sealer will be used later.

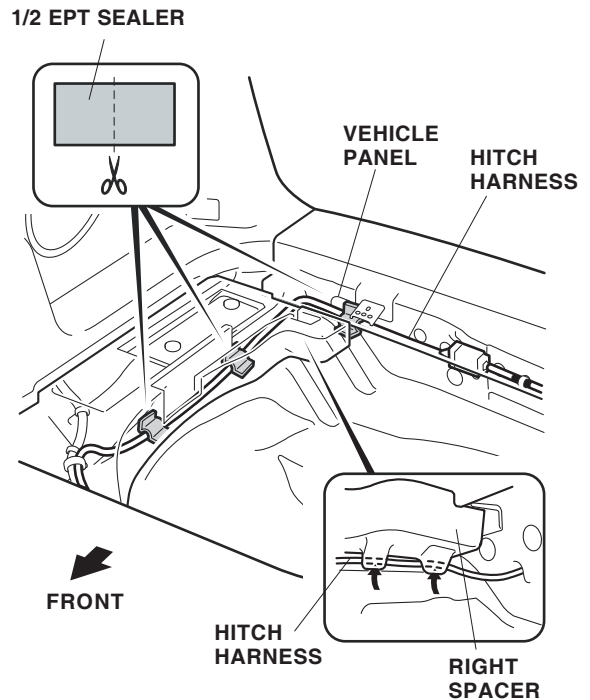

With Backup Sensors: Trim the corner of the right spacer to accommodate both wire harnesses.

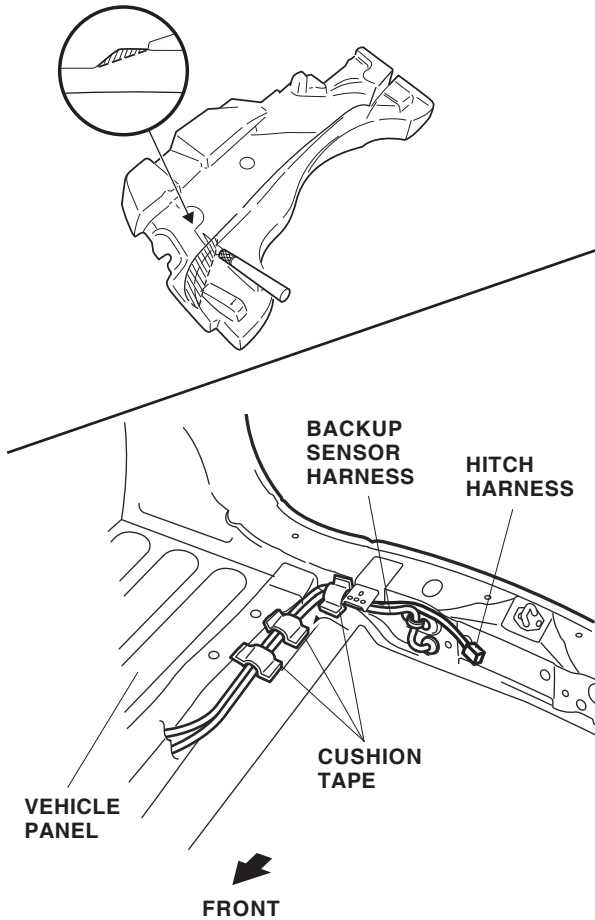

20. Plug the trailer hitch harness 4-pin connector into the trailer socket harness 4-pin connector.

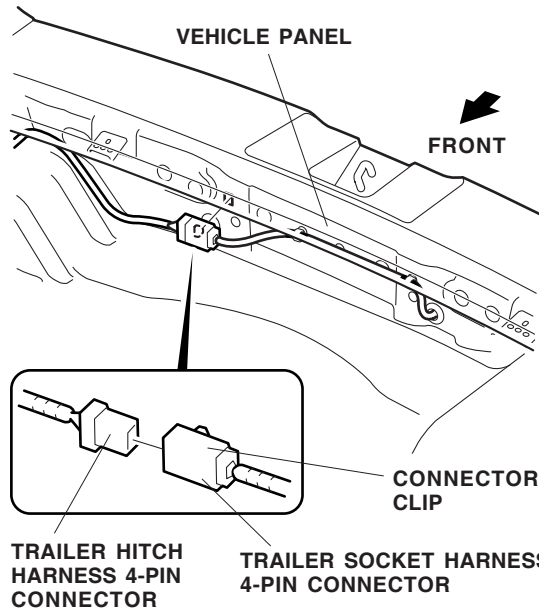

21. Secure the trailer socket harness 4-pin connectors to the vehicle panel using the connector clip.

22. Route the trailer socket harness (installed in step 13) along the trailer hitch. Secure the trailer socket harness to the trailer hitch using two wire ties.

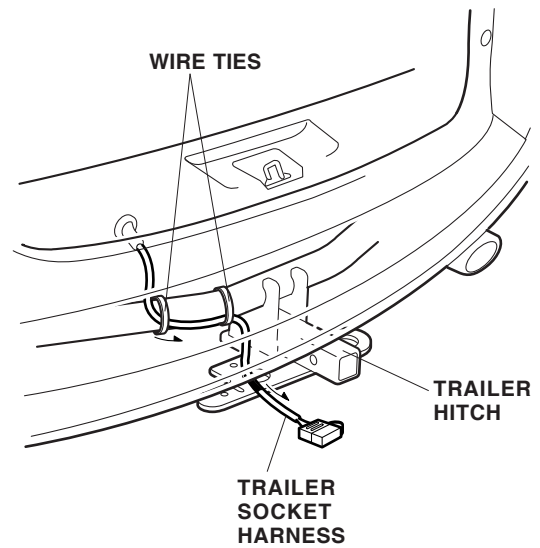

23. Attach the trailer socket harness 4-pin connector to the trailer hitch using the 6 x 16 mm flange bolt and the 6 mm flange nut.

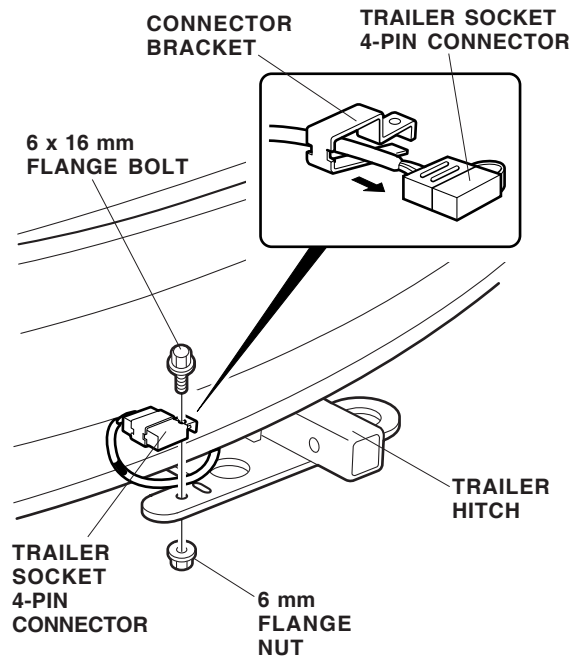

24. Secure the trailer hitch trailer socket harness to the trailer hitch at the green tape using one wire tie.

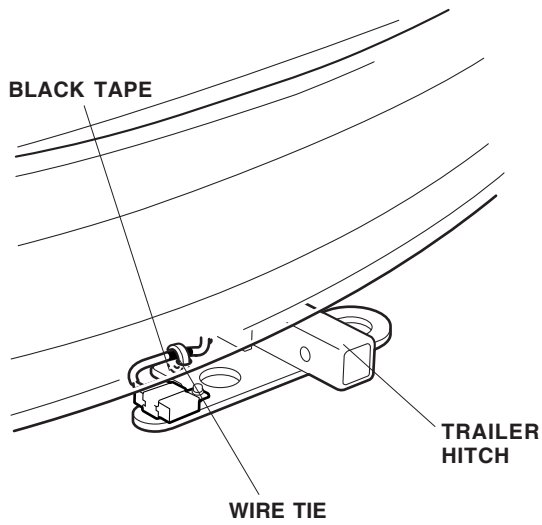

Installing the Control Unit

25. Install the two jack nuts into the vehicle panel holes. Using the 6 x 20 mm flange bolt, install the jack nuts by tightening the flange bolts until the jack nut is collapsed. Remove the flange bolt.

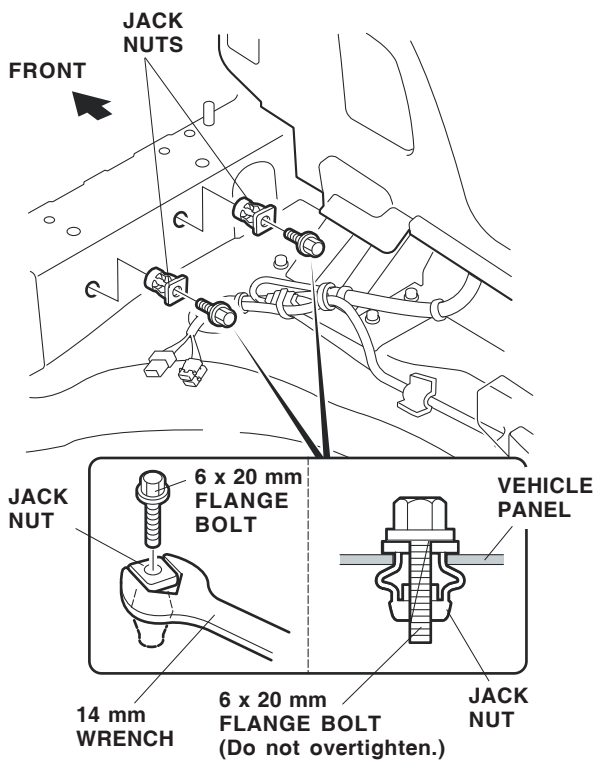

26. Using isopropyl alcohol on a shop towel, clean the vehicle panel surface where the EPT sealer will attach. Attach the remaining cut piece of EPT sealer to the floor panel in the area shown.

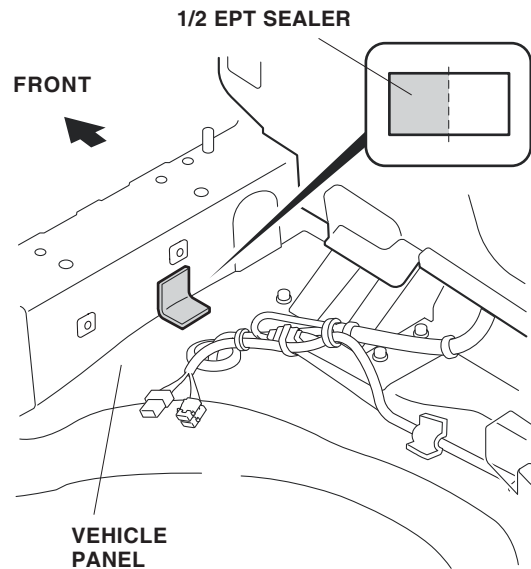

27. Install the control unit bracket to the control unit.

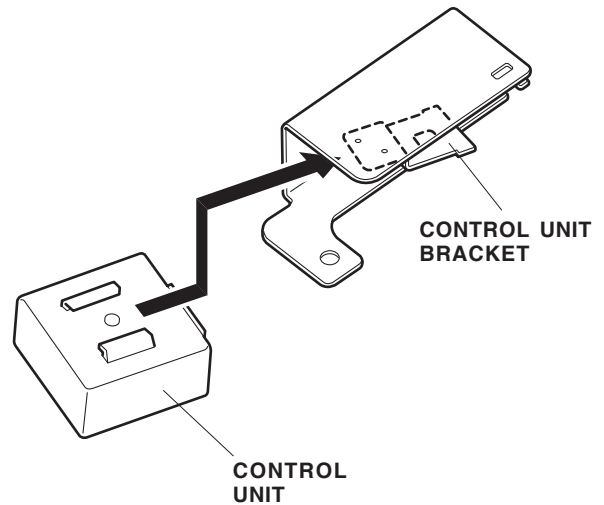

28. Attach the 7.5A and 5A fuse labels to the fuse cases on the trailer hitch harness.

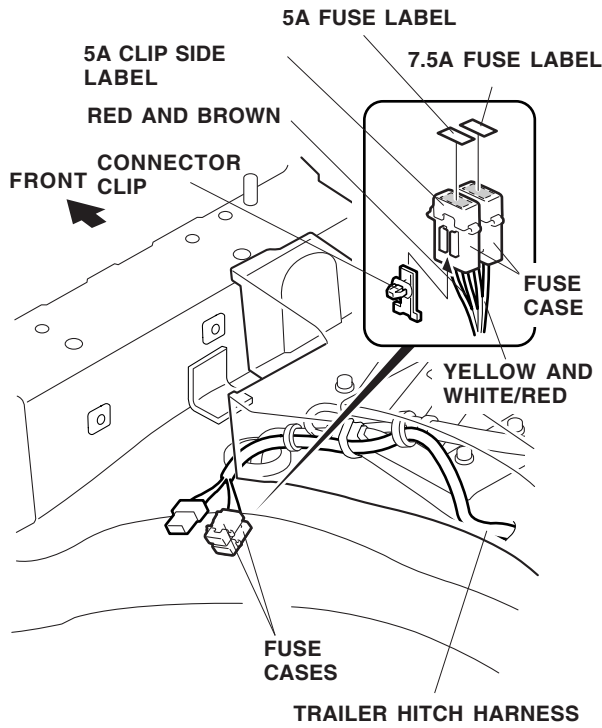

29. Install the connector clip to the trailer hitch harness fuse case.
30. Reinstall the right spacer.

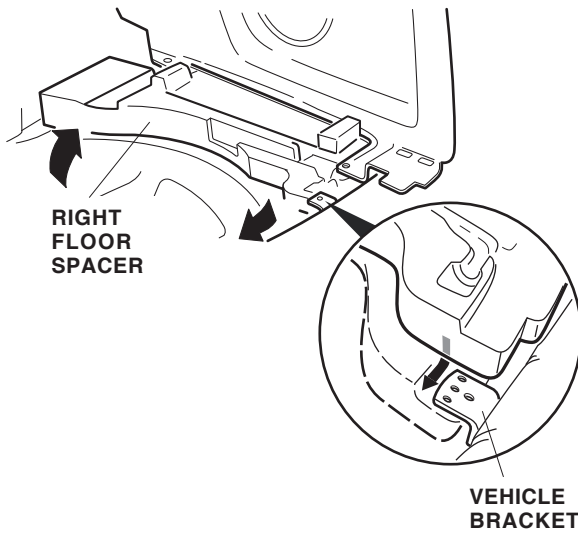

31. Loosely install one 6 x 20 mm flange bolt into the right jack nut.

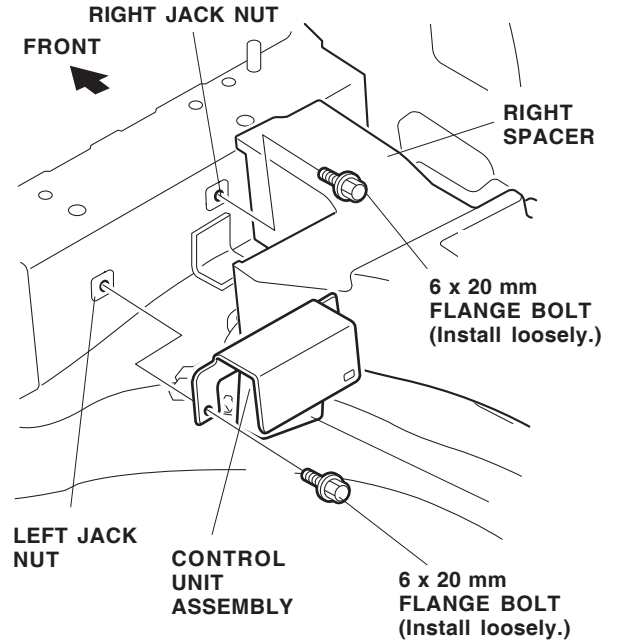

32. Attach the control unit bracket to the vehicle panel using one 6 x 20 mm flange bolt into the left jack nut. Do not tighten the flange bolt at this time.
33. Plug the trailer hitch harness 12-pin connector into the control unit, and secure the fuse case connector clip to the bracket.

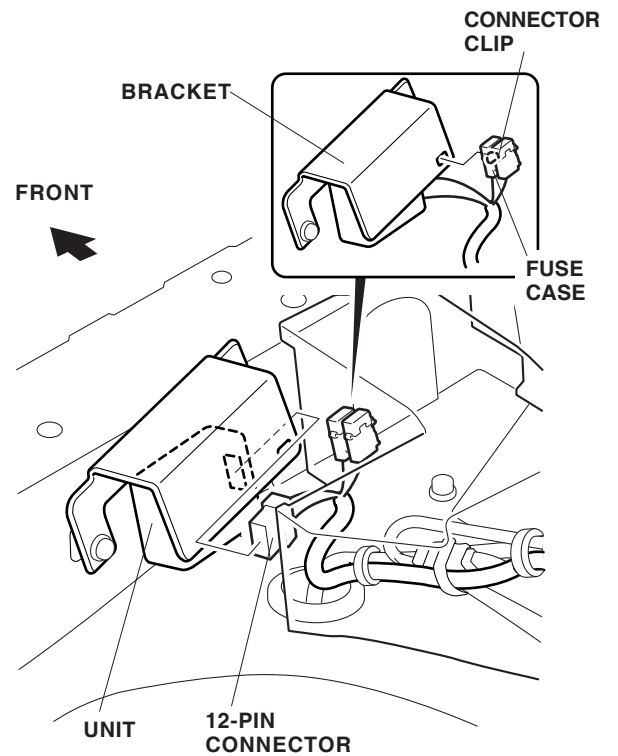

34. Rotate the control unit assembly down onto the right flange bolt. Torque both 6 x 20 mm flange bolts to 4.0 N·m (3.0 lb-ft).

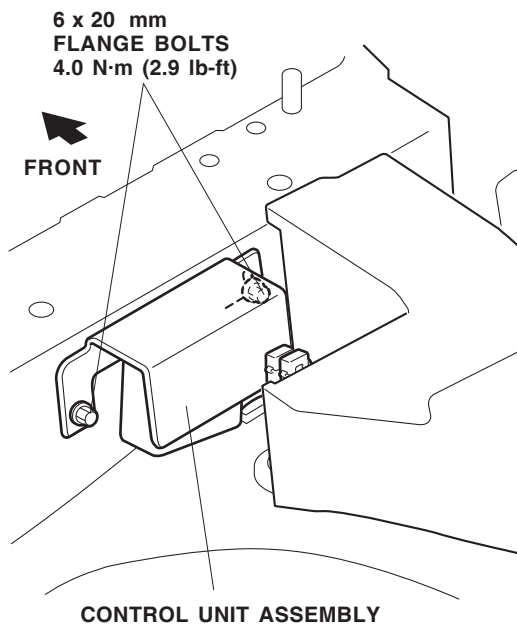

35. Check that all wire harnesses are routed properly and all connectors are plugged in.

Installing the Trailer Hitch

If the vehicle you are working on has a rear diffuser, continue with step 36; otherwise, go to step 40.

36. With the vehicle on a hoist, position template B on the rear diffuser, and tape in place.

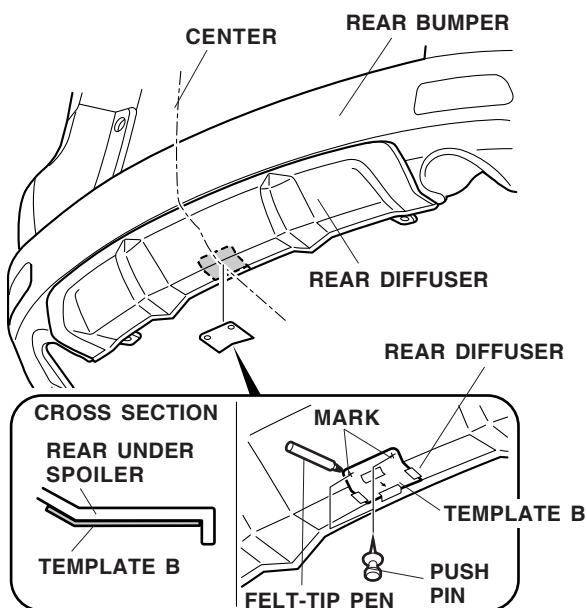

37. Using a pushpin, pierce the diffuser at both cross marks. Using a felt-tip pen, mark the outline of the template, then remove the template.

38. While wearing eye protection, drill a 10 mm hole through the rear bumper and the rear diffuser. First drill with a 3 mm drill bit and finish with a 10 mm drill bit.

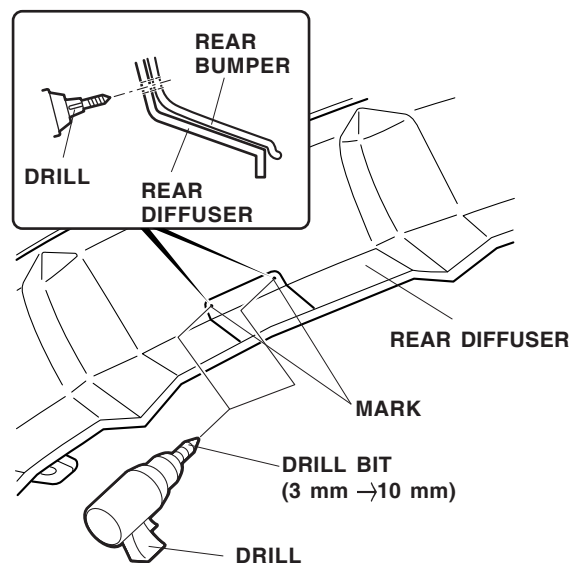

39. Using a saw blade, cut out the rear diffuser along the outline marks you made in step 37. Then, go to step 44.

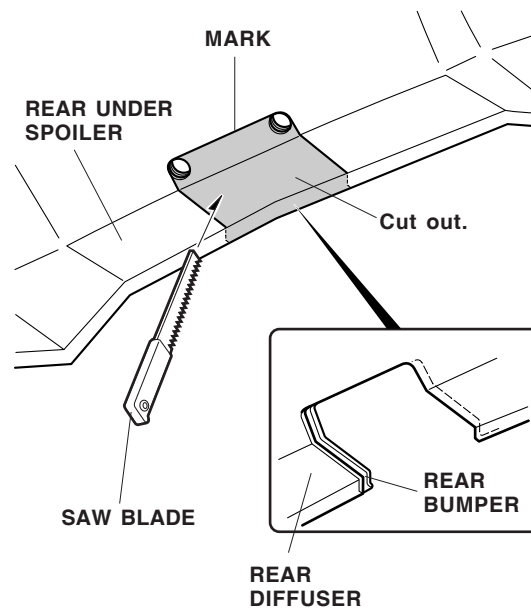

40. With the vehicle on a hoist, position template A on the rear bumper, and tape in place.

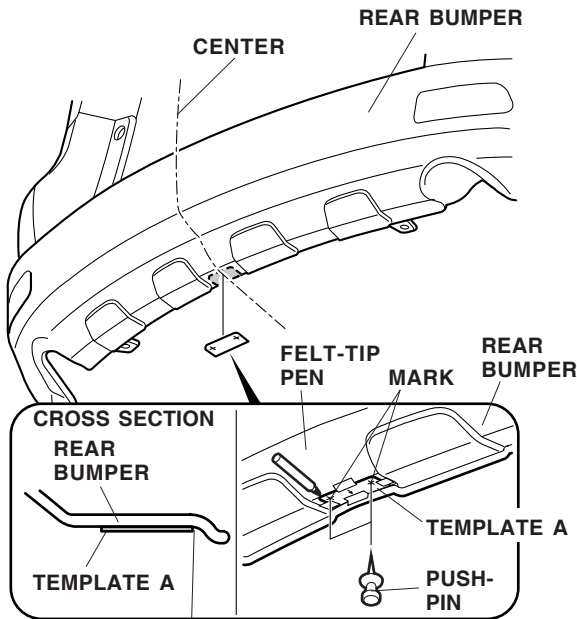

Align with the end of the straight section.

41. Using a pushpin, pierce the rear bumpers at both cross marks. Using a felt-tip pen, mark the outline of the template, then remove the template.
42. While wearing eye protection, drill a 10 mm hole through the rear bumper at the marked locations. First drill with a 3 mm drill bit and finish with a 10 mm drill bit.

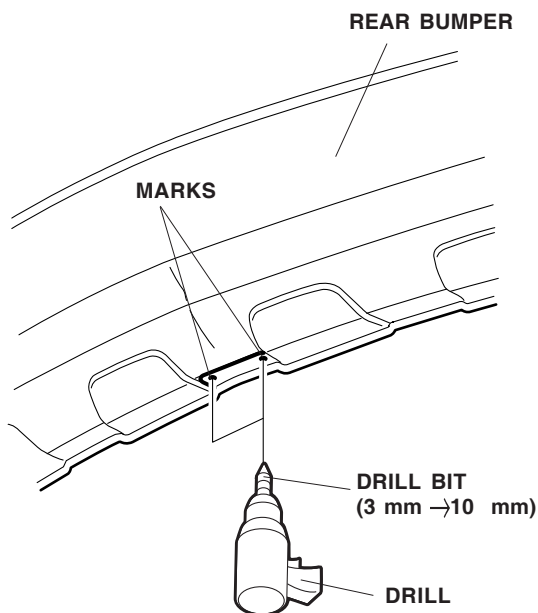

43. Using a saw blade, cut out the rear bumper along the marks you made in step 41.

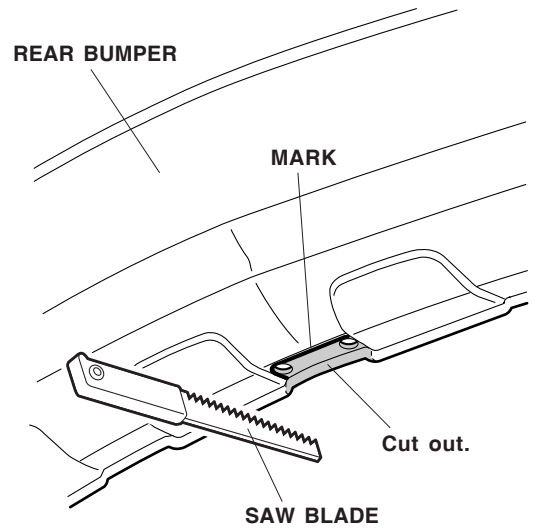

44. Remove the four vehicle grommets from the vehicle.

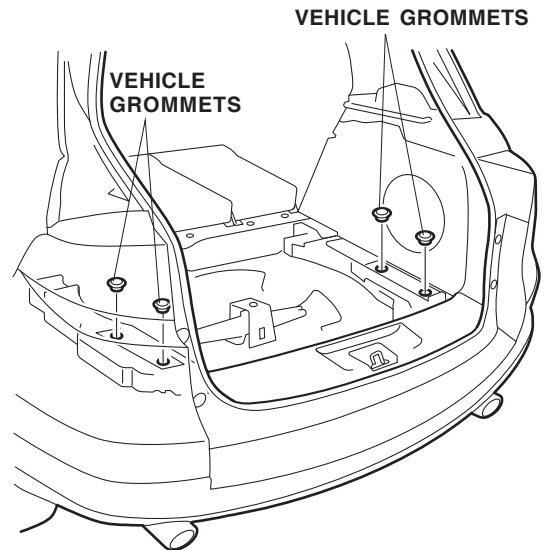

45. Insert the right and left plates into the holes exposed in step 44.

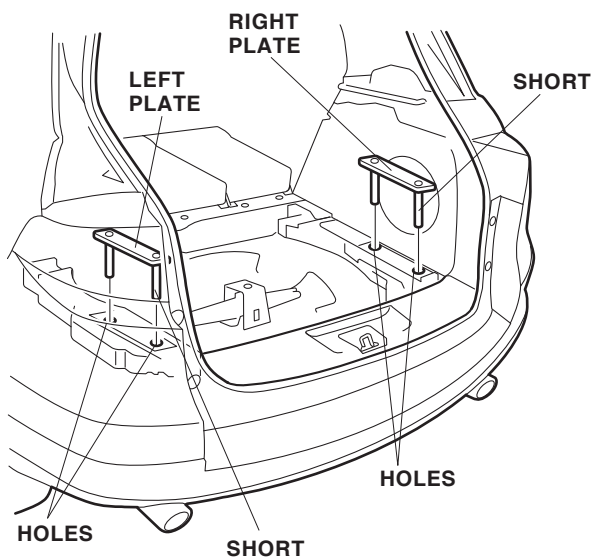

46. Install the trailer hitch on the right and left stays using eight plain washers, four lock washers, four nuts, two 12 x 190 mm bolts, and two 12 x 175 mm bolts. Torque (12 x 190 mm bolt and 12 x 175 mm bolt): 79 N·m (58 lb-ft).

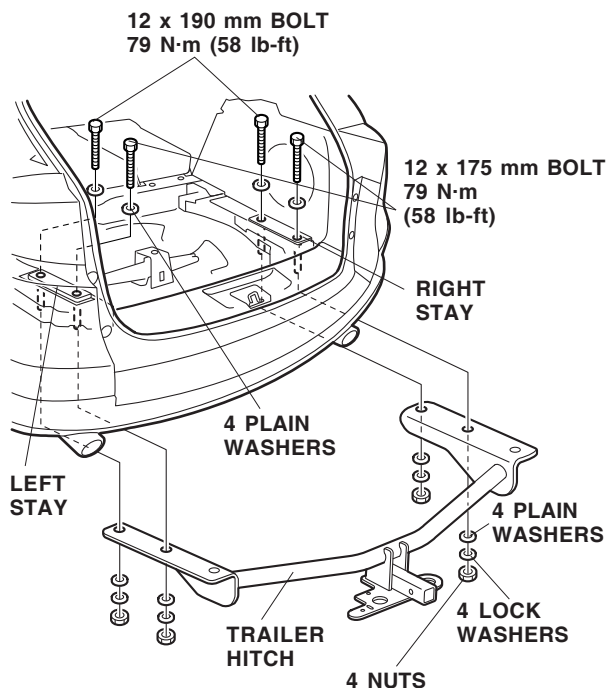

47. Install the two 12 x 40 mm bolts with plain washers and lock washers. Torque (12 x 40 mm bolt): 79 N·m (58 lb-ft).

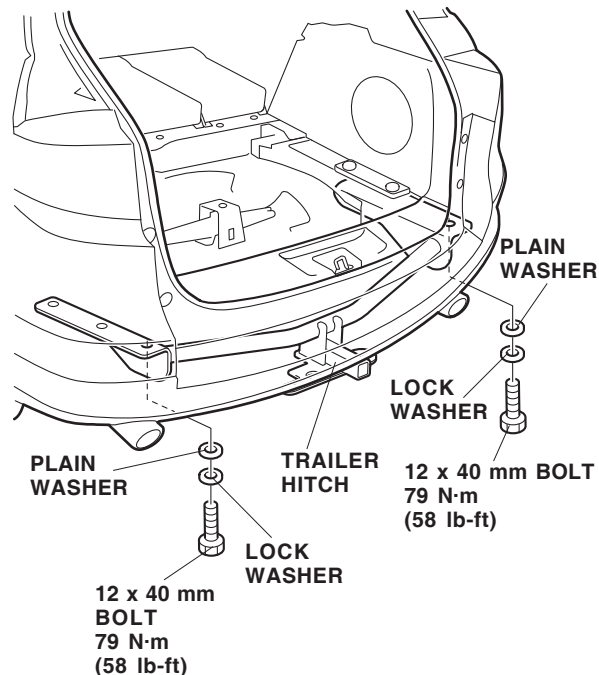

48. Check that all wire harnesses are routed properly and all connectors are plugged in.
49. Reinstall all removed parts.
50. Reconnect the negative cable to the battery.
51. Enter the client's radio anti-theft code, and reset the radio station presets.
52. Reset the clock.

NOTE: Whenever the battery is disconnected, the driver's window AUTO function is disabled.

- Start the engine. Push down on the driver's window switch until the window is fully open.
- Pull up on the driver's window switch to close the window completely, then hold the switch for 2 seconds or more.
- Lower and raise the window to check the operation of the driver's window AUTO function.

Give a copy of this page to your client.

Installing the Receiver Cover

Whenever you remove the hitch pin clip, the hitch pin, and the ball mount, store them securely in the cargo area. Install the receiver cover into the opening at the end of the trailer hitch. When you reinstall the ball mount, store the receiver cover in the cargo area. After the first 600 miles (1,000 km) of towing, have your Acura dealer recheck the tightness of the trailer hitch bolts.

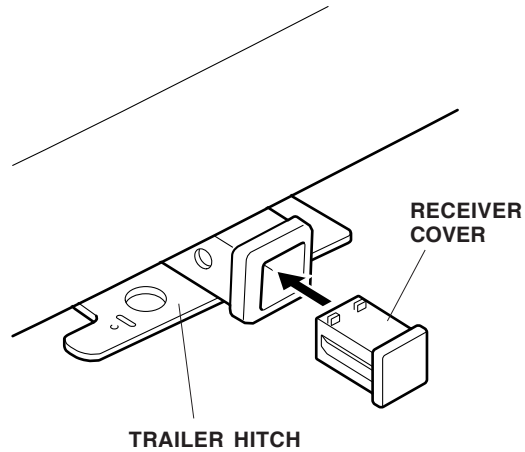

Install the ball mount on the trailer hitch using the hitch pin clip and hitch pin.

