



ACURA INSTALLATION INSTRUCTIONS

Accessory
STEERING WHEEL

Application
2009 MDX

Publications No.
BII 39887
Issue Date
JULY 2008

PARTS LIST

Steering wheel



2 TORX bolts



Important Information

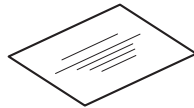

TOOLS REQUIRED

Phillips screwdriver
Flat-tip screwdriver
19 mm T-handle wrench
Torque wrench
Steering wheel puller
T30 TORX bit

INSTALLATION

Client Information: The information in this installation instruction is intended for use only by skilled technicians who have the proper tools, equipment, and training to correctly and safely add equipment to your vehicle. These procedures should not be attempted by “do-it-yourselfers.”

NOTE:

- Observe all safety notes and precautions described in the service manual in addition to these described in this installation instruction.
- After installing the steering wheel, you must align the steering wheel spoke angle to the straight-ahead position by adjusting the front toe.

1. Make sure you have the anti-theft codes for the radio and navigation system (if equipped), then write down the radio presets.
2. Disconnect the negative cable from the battery, and wait for at least 3 minutes before installing the steering wheel.
3. From underneath the driver’s airbag, pry up on the four retaining tabs, and remove the access panel.
4. Remove the horn ground terminal and the airbag connectors from the holder on the cord guide. Unplug the horn ground terminals.

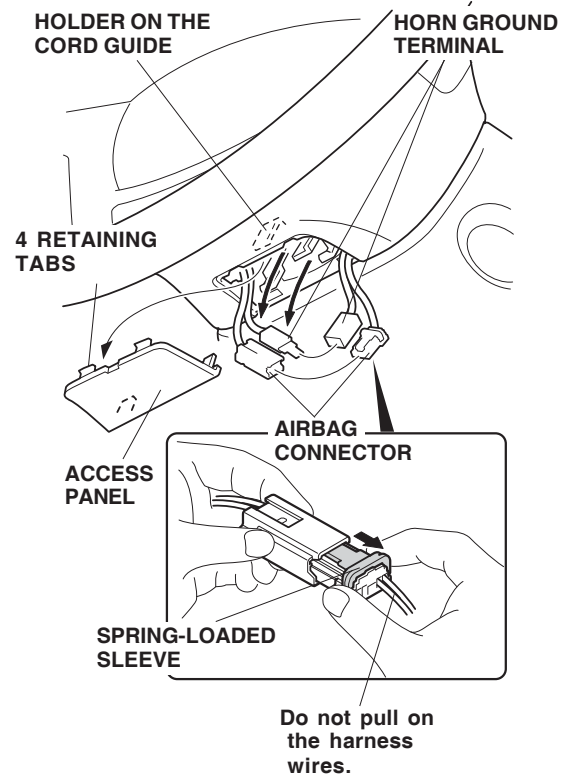

5. Unplug the airbag connectors. To release the lock, pull the spring-loaded sleeve towards the stop while holding the opposite half of the airbag connector. Then pull the airbag connector halves apart. Make sure to pull on the sleeve and not on the airbag connector.

- Remove and discard the two TORX bolts that secure the airbag, and remove the airbag. Carefully set the airbag in a secure location with the pad facing up. Do not drop or bump the airbag against anything.

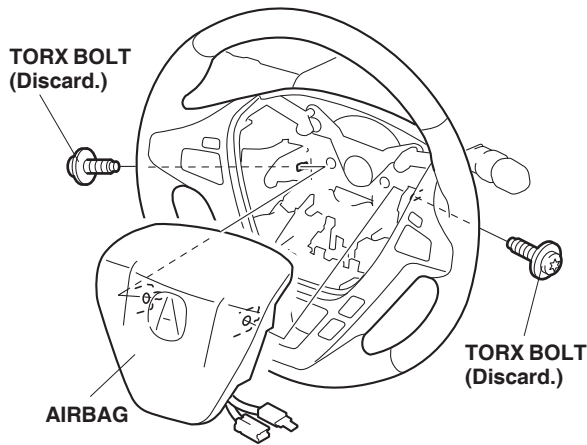

- Turn the steering wheel so the front wheels are in the straight-ahead position.
- Remove the steering wheel bolt. Disconnect the vehicle 20-pin connector from the cable reel. Using a steering wheel puller, remove the steering wheel. Do not thread the steering wheel puller bolts in more than 10 mm. Be careful not to move the steering wheel during removal.

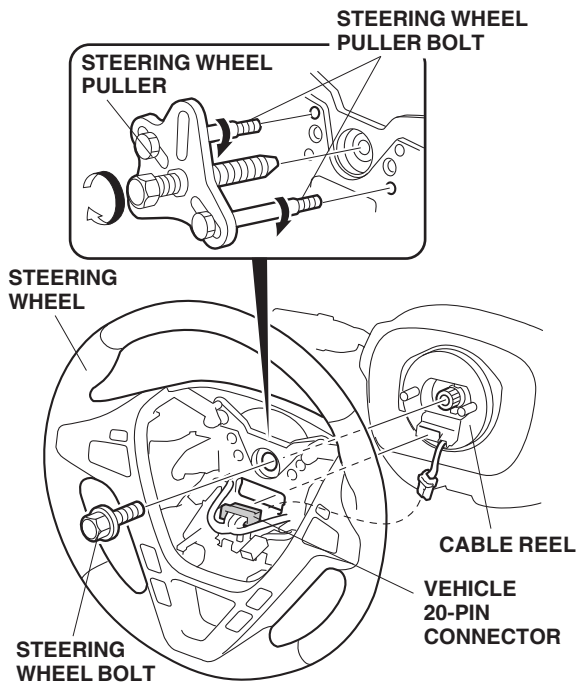

- Remove the eight self-tapping screws that fasten the steering wheel cover to the steering wheel, and remove the steering wheel cover.

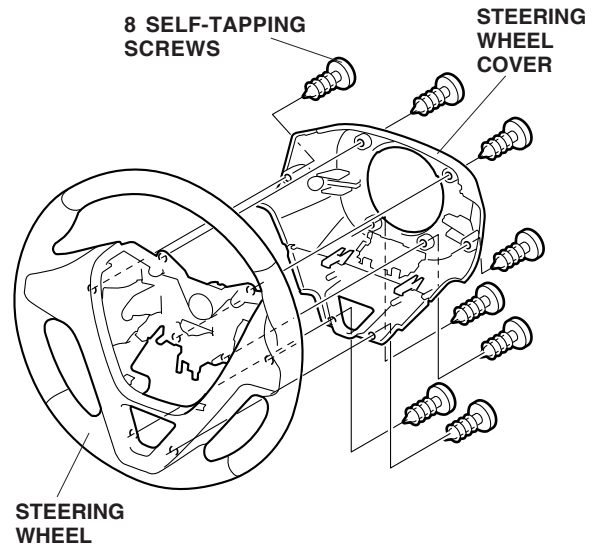

- Remove the switch panel by releasing the cord from the retaining tabs on the steering wheel.

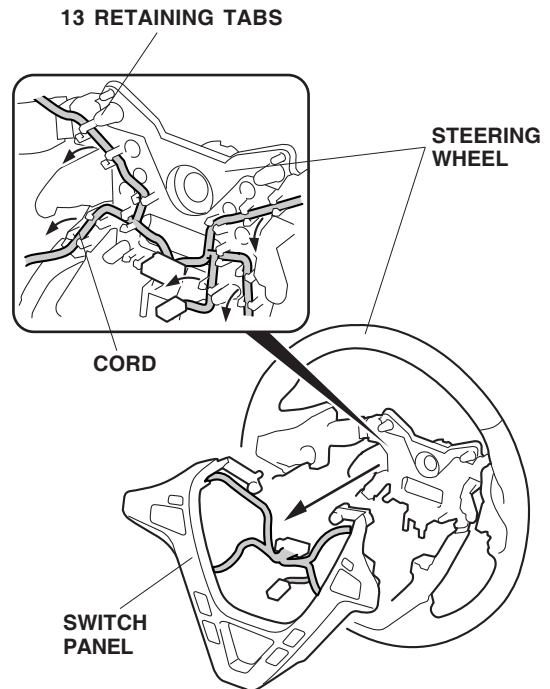

11. Pry up the six retaining tabs and remove the cord guide from the steering wheel.

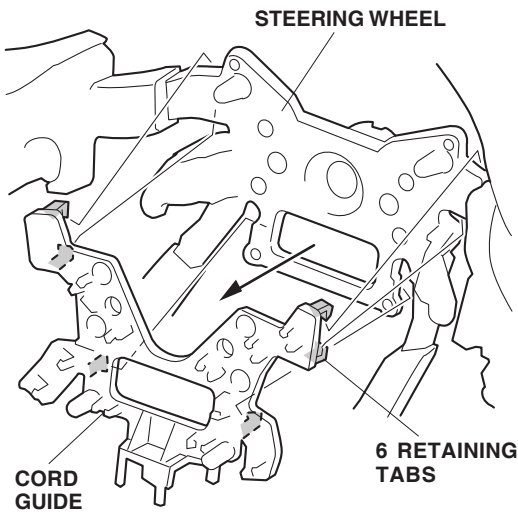

12. Install the cord guide on the new steering wheel.

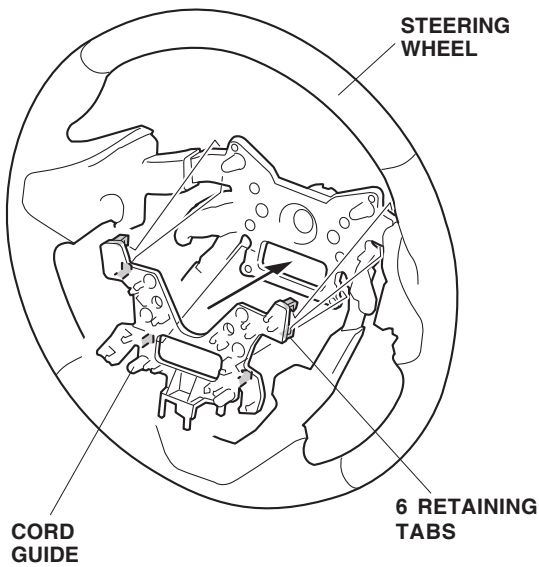

13. Position the switch panel to the steering wheel, and attach the cord to the retaining tabs on the steering wheel.

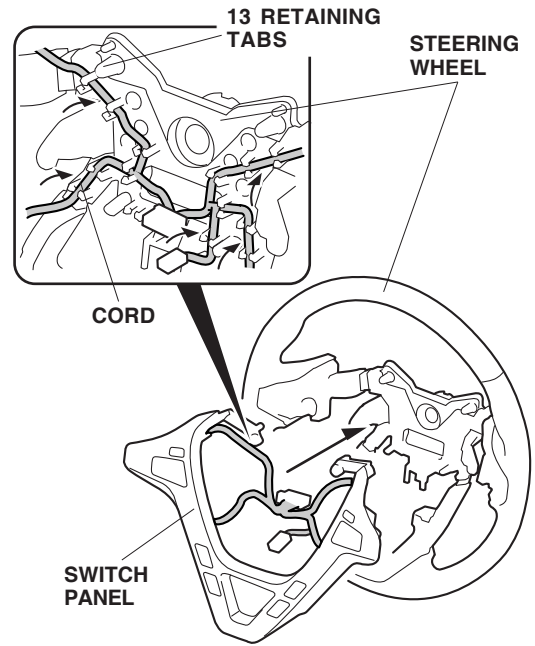

If the steering wheel does not have a ground bolt go to step 16: otherwise, continue with step 14.

14. Using the ground bolt, connect the ground wire to the steering wheel as shown.

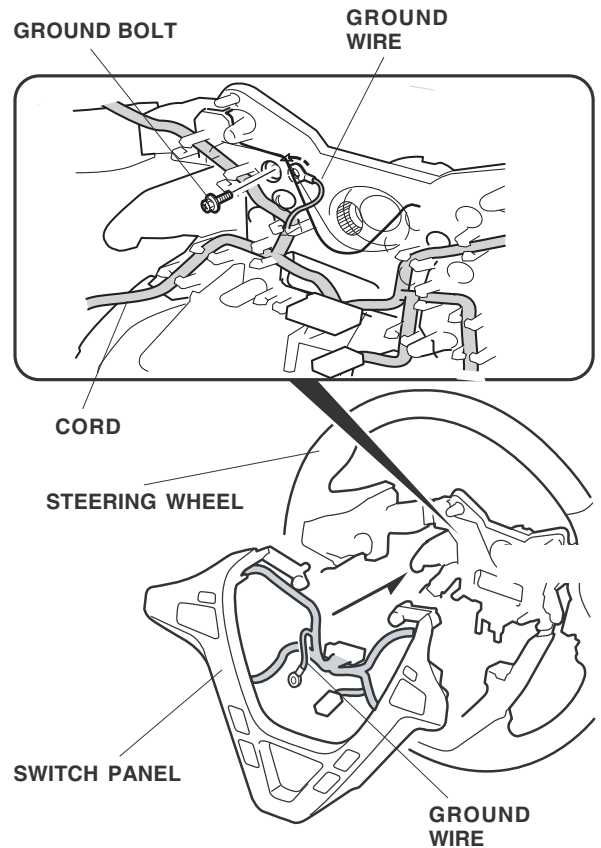

15. Install the steering wheel cover to the steering wheel with the eight self-tapping screws.

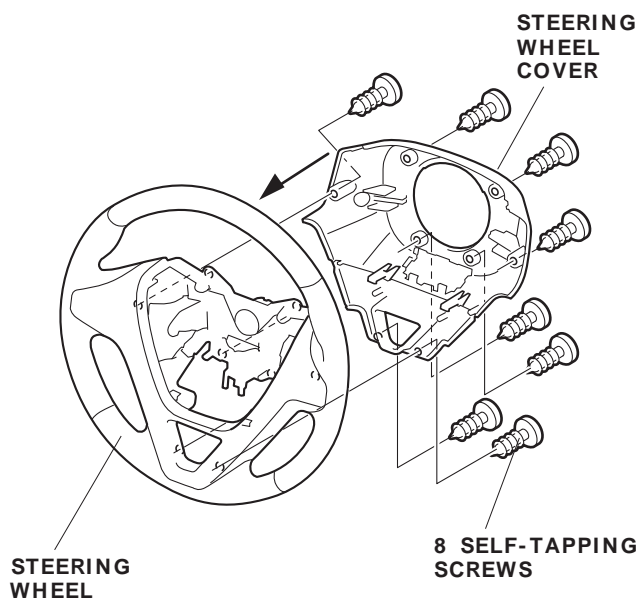

16. Connect the wire between the steering wheel and cord guide.

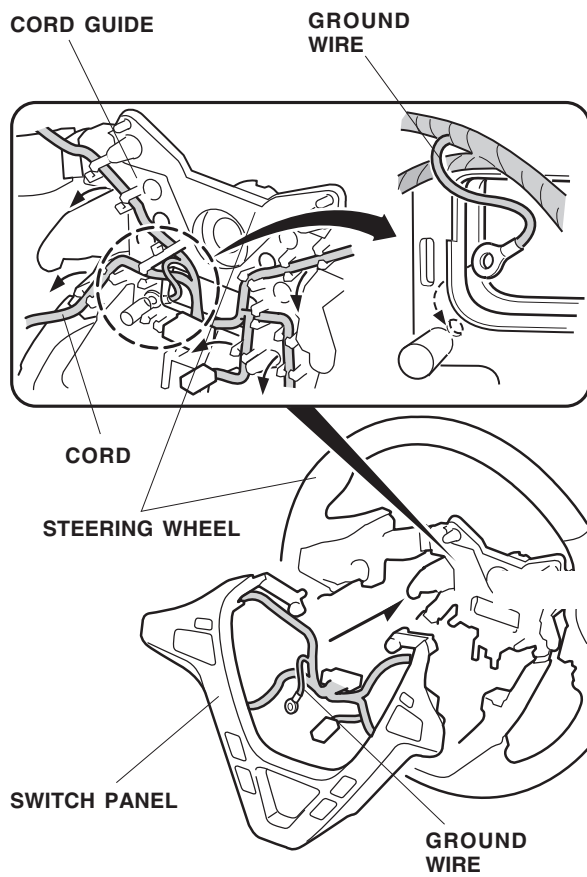

17. Install the steering wheel cover to the steering wheel with the eight self-tapping screws. Secure the ground wire with the self-tapping

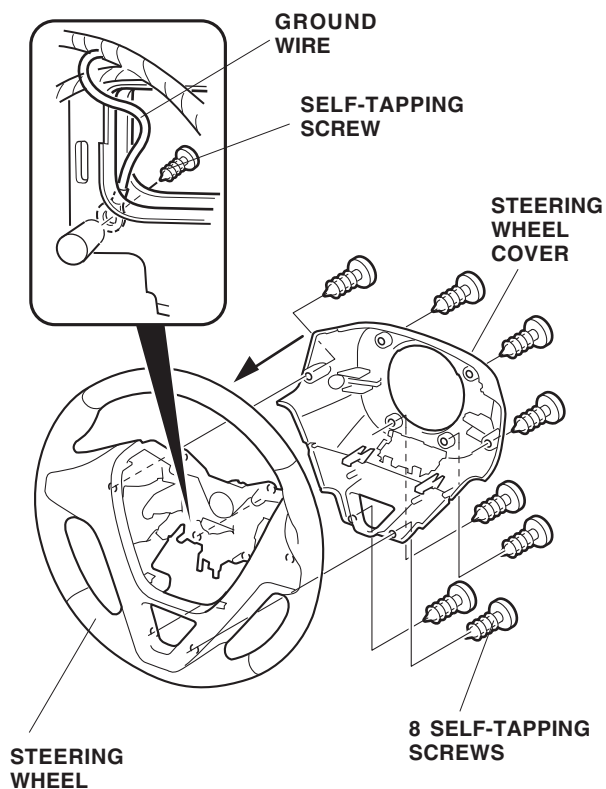

18. Install the steering wheel on the steering column shaft in the straight-ahead position:
 - Route the wire harness through the opening in the steering wheel.
 - Align the two tabs of the canceling sleeve with the two cutouts in the steering wheel as shown.
 - Check that the wire harness is not pinched.

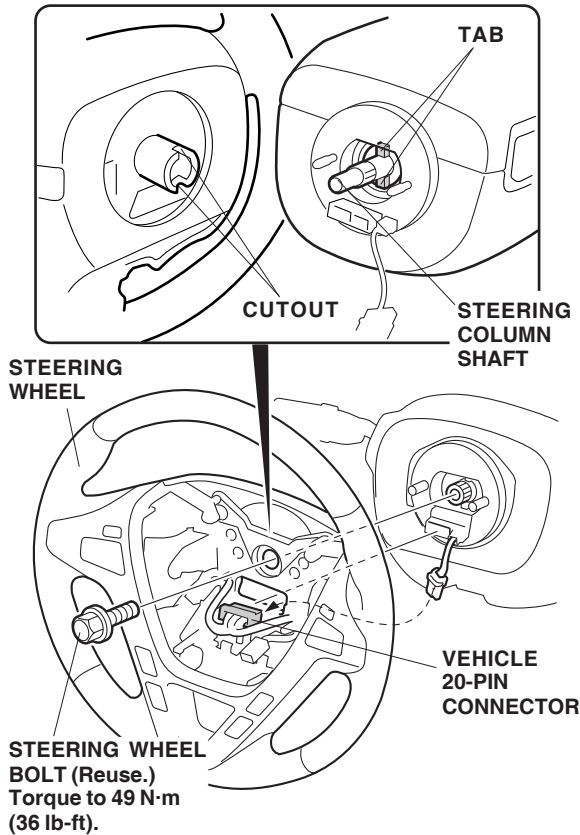

19. Install the steering wheel bolt. Torque the steering wheel bolt to 49 N·m (36 lb-ft).
20. Reconnect the 20-pin connector.

21. Get the airbag, and route the airbag harness and horn harness down through the steering wheel. Position the airbag on the steering wheel, and install the two new TORX bolts. Torque the TORX bolts to 10 N·m (7.4 lb-ft). Check that the harnesses are not pinched.

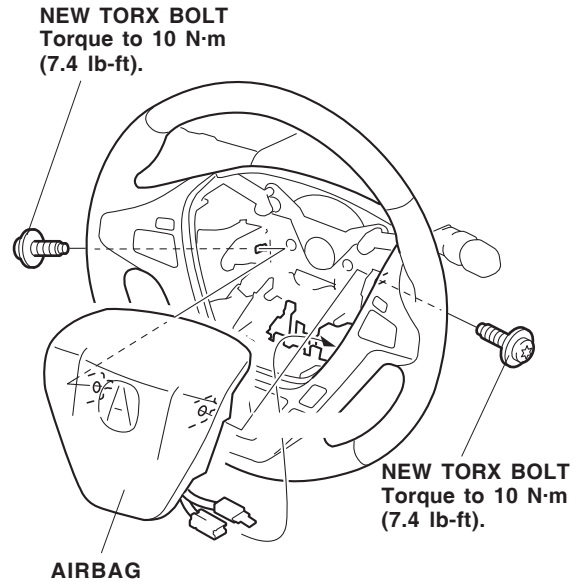

22. From under the steering wheel, connect the horn ground terminals, and attach the terminals to the holder on the cord guide.

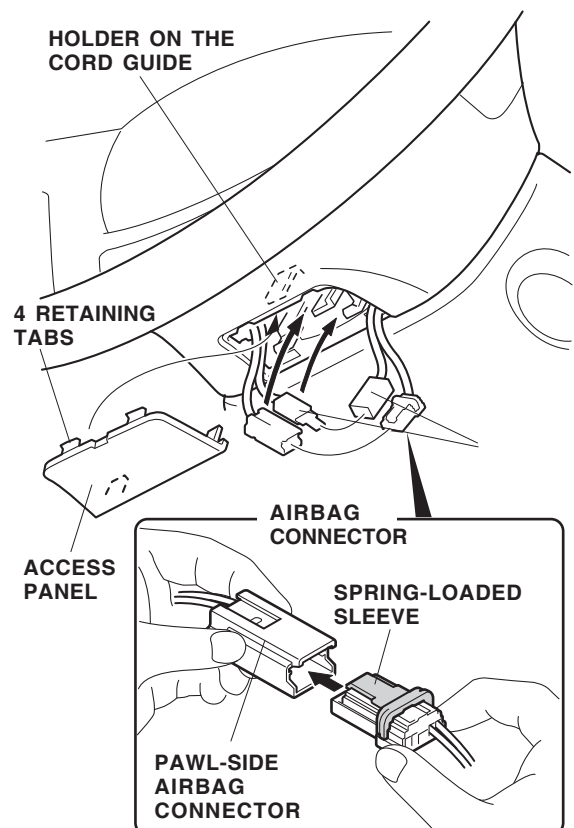

23. To reconnect, hold the pawl-side airbag connector, and press on the back of the sleeve-side airbag connector in the direction shown. As the two airbag connector halves are pressed together, the sleeve is pushed back by the pawl. Do not touch the sleeve.
24. Reattach the airbag harness connectors to the holder on the cord guide.
25. Reinstall the access panel.
26. Reconnect the negative battery cable to the battery, and do these tasks:
 - Turn the ignition switch to ON (II); the SRS indicator should come on for about 6 seconds and then go off.
 - Enter the anti-theft code for the audio system and the navigation system (if equipped), and reenter the radio presets.
 - Make sure the horn and turn signal switches work properly.
 - Make sure the steering wheel switches work properly.
27. Reset the steering column position memorization:
 - Insert the built-in key into the ignition switch, and remove it.
 - The steering wheel automatically moves fully in and up to let you know the system is reset.
28. Reset the clock.

NOTE: Whenever the battery is disconnected, the driver's window AUTO function is disabled.

- Start the engine. Push down on the driver's window switch until the window is fully open.
- Pull up on the driver's window switch to close the window completely, then hold the switch for 2 seconds or more.
- Lower and raise the driver's window to check the operation of the driver's window AUTO function.
- Make sure the steering wheel is in the straight-ahead position with the front wheels. If the spoke angle of the steering wheel is not in the straight-ahead position with the front wheels, adjust the front toe as described in the service manual.