

Accessory	Application	Publications No.
<b>BACKUP SENSOR</b>	<b>2009 MDX</b>	<b>BII 39890</b>
		Issue Date <b>JULY 2008</b>

**PARTS LIST**

**Backup Sensor Attachment Kit**  
**P/N 08V67-STX-200A**

Control unit

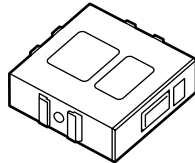

Buzzer

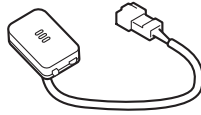

2 Corner sensor clips



Left center sensor clip  
(White)

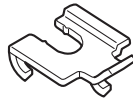

Right center sensor clip  
(Black)

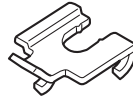

Backup sensor harness

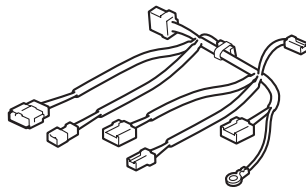

Subharness

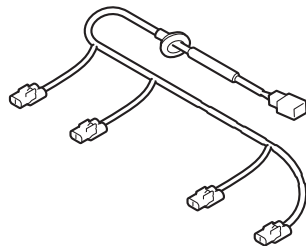

Control unit bracket

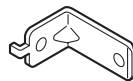

Grommet



Self-tapping screw, 5 x 16 mm



12 Wire ties

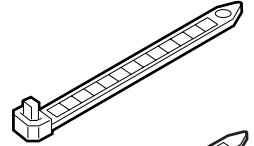

5 Wire ties with clips

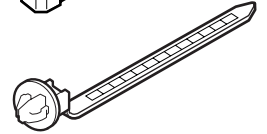

4 Clips



2 Self-tapping screws, 4 x 14 mm



2 Washers



Fuse label

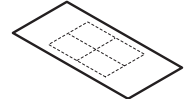

EPT sealer

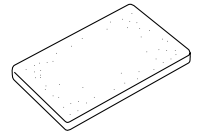

Accessory User's Information Manual

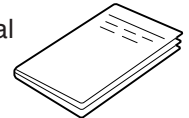

**Backup Sensor Kit**

2 Corner sensors

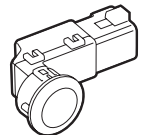

Right center sensor

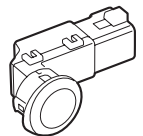

Left center sensor

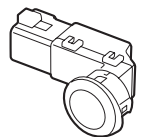

## TOOLS AND SUPPLIES REQUIRED

Phillips screwdriver  
Small flat-tip screwdriver  
Ratchet  
8 mm and 10 mm Socket  
Pushpin  
Eye protection (face shield, safety goggles, etc.)  
Drill  
3 mm and 5 mm Drill bit  
16 mm, 24 mm, and 26 mm Hole saw  
File  
Piece of wire  
Tape measure  
Felt-tip pen  
Diagonal cutters  
Torque wrench  
Blanket  
Isopropyl alcohol  
Shop towel

## Illustration of the Backup Sensor Installed on the Vehicle

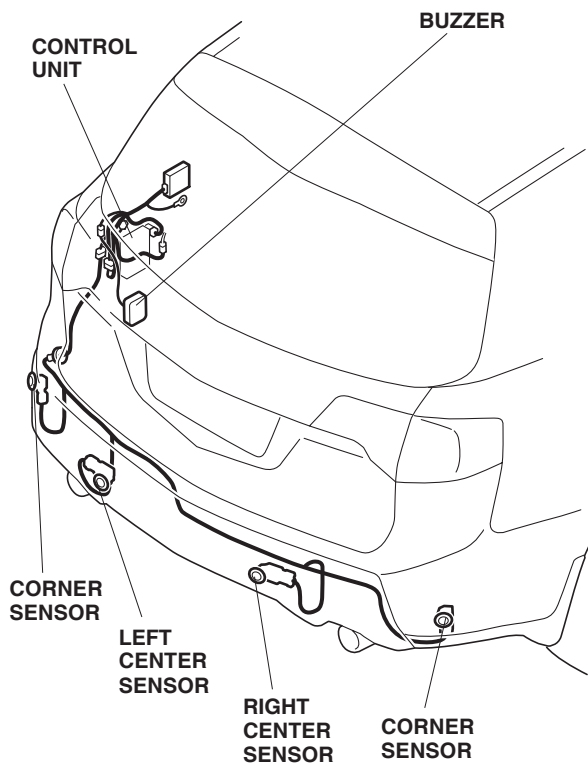

## INSTALLATION

**Client Information:** The information in this installation instruction is intended for use only by skilled technicians who have the proper tools, equipment, and training to correctly and safely add equipment to your vehicle. These procedures should not be attempted by “do-it-yourselfers.”

1. Make sure you have the anti-theft code for the radio, then write down the radio station presets.
2. Disconnect the negative cable from the battery.
3. Open the tailgate. With the help of an assistant, remove the rear bumper (four caps, four bolts, twelve self-tapping screws, and four clips). Set the rear bumper on the blanket to prevent damage.

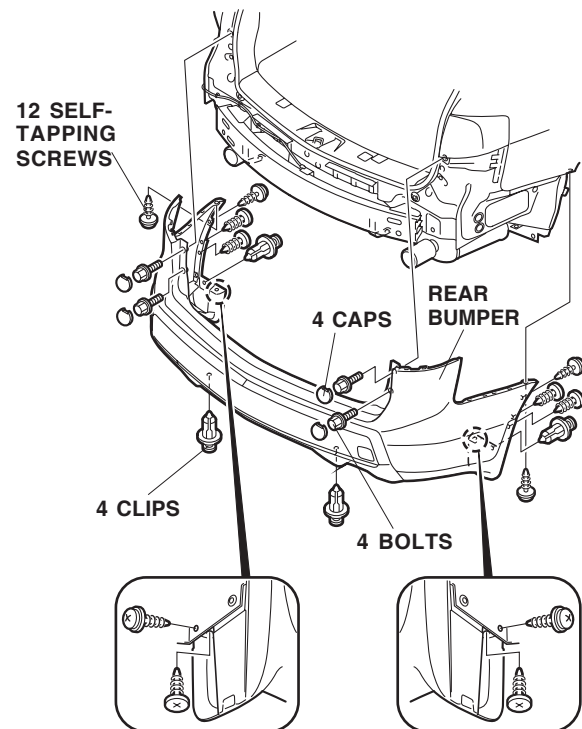

- Using diagonal cutters, cut the rear bumper in two places using the measurements shown.

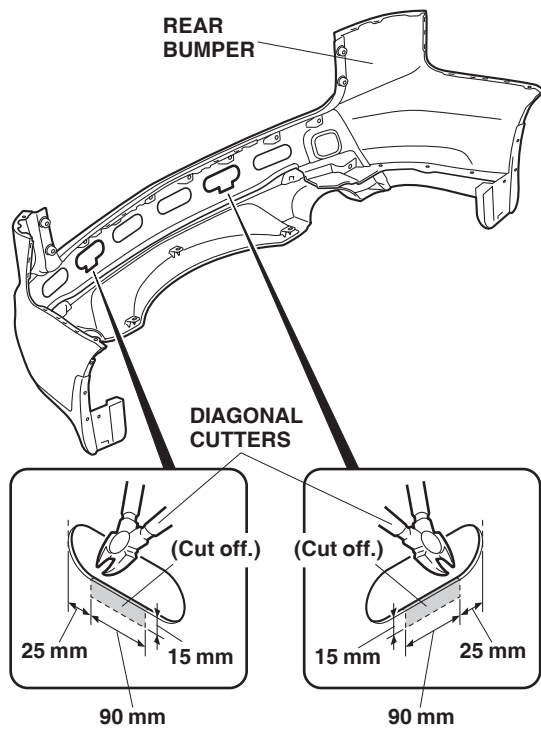

- On the inside of the lower trim, locate the two preset marks. Using a pushpin, pierce through the lower trim at the center and top of the two marks.

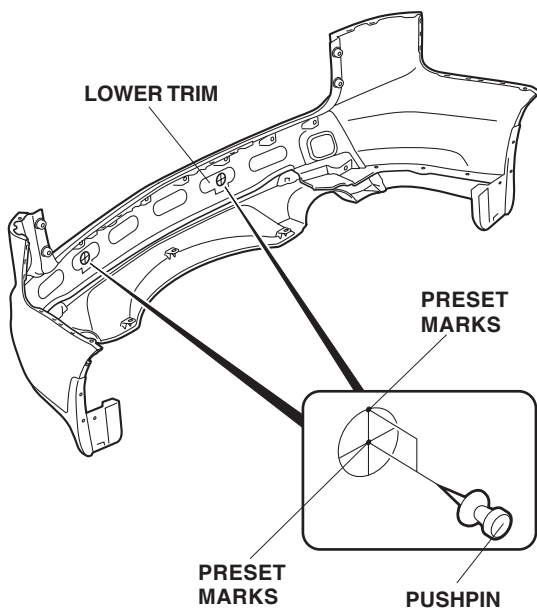

- While wearing eye protection, drill the lower trim from the painted side at each pierced mark you made. First drill each mark with a 3 mm drill bit, then drill each lower mark with a 26 mm hole saw. Remove any burrs from the edges of the holes with a file.

NOTE: The top hole must be drilled exactly at the 12 o'clock position for the sensor to operate correctly.

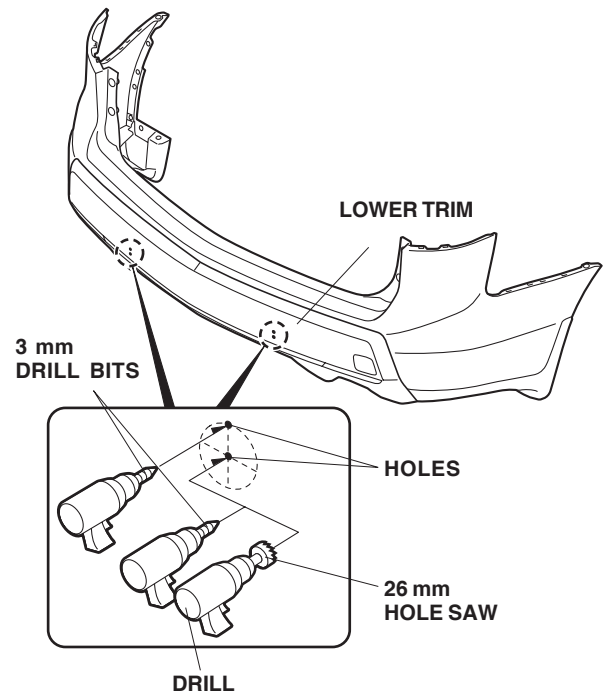

- On the inside of the rear bumper, locate the two preset marks. Using a pushpin, pierce through the rear bumper at the center and top of the two marks.

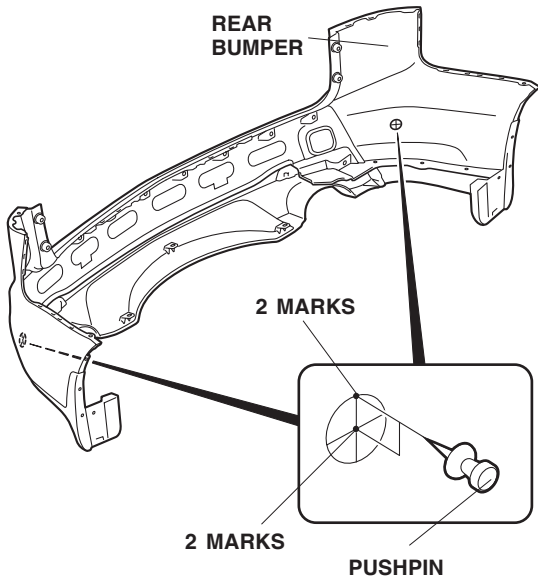

- While wearing eye protection, drill the rear bumper from the painted side at each pierced mark you made. First drill each mark with a 3 mm drill bit, then drill each lower mark with a 24 mm hole saw. Remove any burrs from the edges of the holes with a file.

NOTE: The top hole must be drilled exactly at the 12 o'clock position for the sensor to operate correctly.

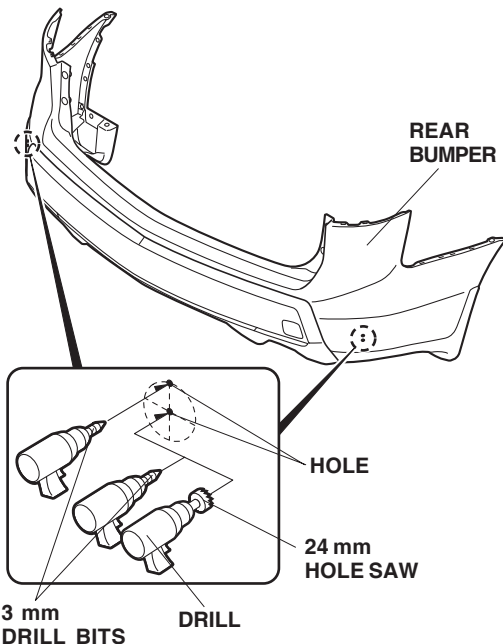

- Install the corner sensors to the rear bumper using the two corner sensor clips.

NOTE: The sensor detent must be positioned at the 12 o'clock position for the sensor to operate correctly.

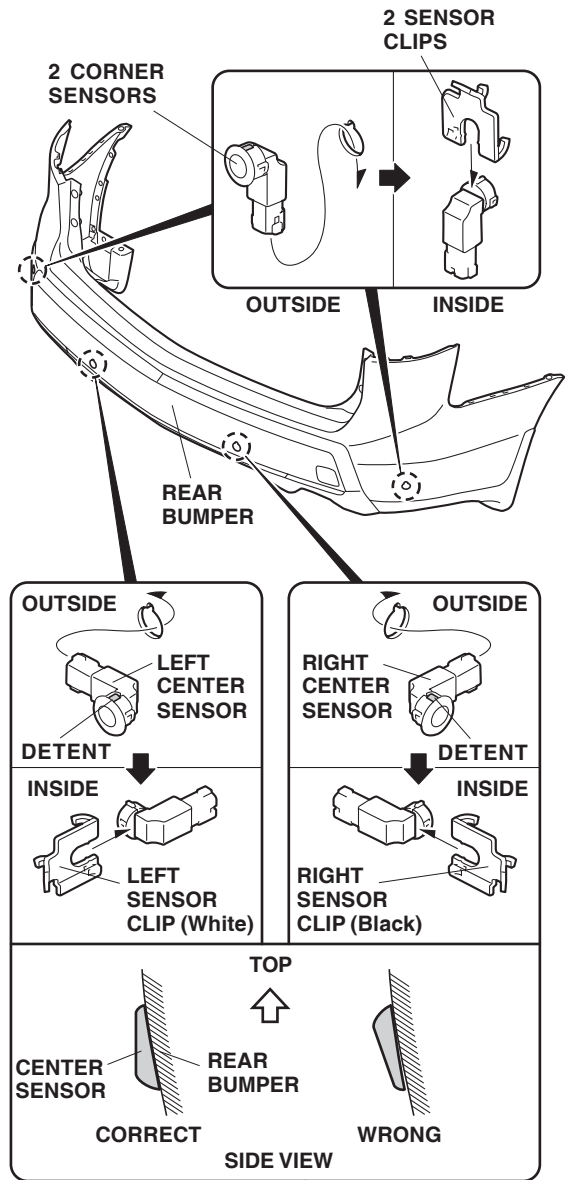

- Install the right and left center sensors on the rear bumper using the right sensor (black) clip for the right sensor and the left sensor (white) clip for the left sensor.

NOTE: The sensor detent must be positioned at the 12 o'clock position for the sensor to operate correctly.

11. Inside the cargo area, raise the lock handle and remove the rear cargo floor lid.

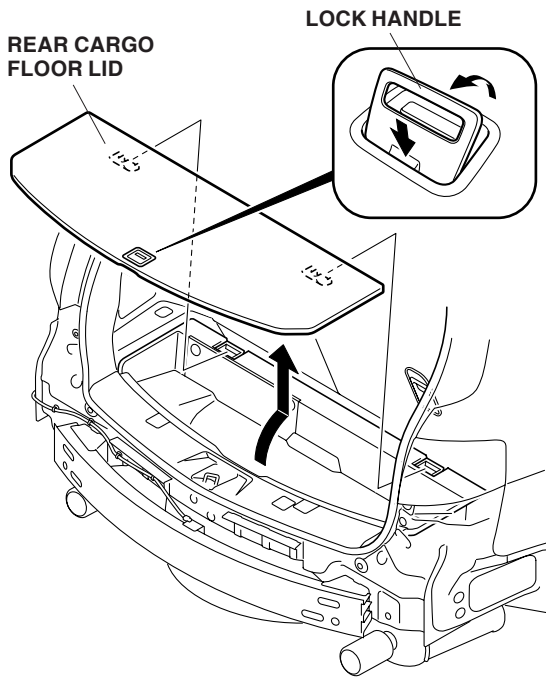

12. Turn the knobs counterclockwise and remove the lid from the rear cargo tray.

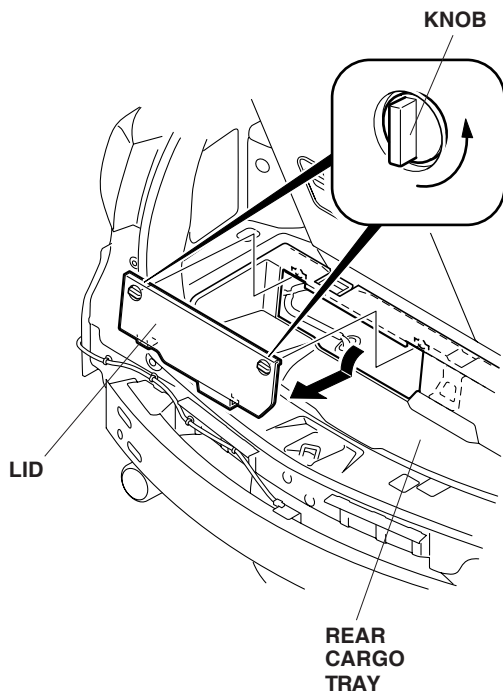

13. Remove the rear trim panel (four retaining tabs and four clips).

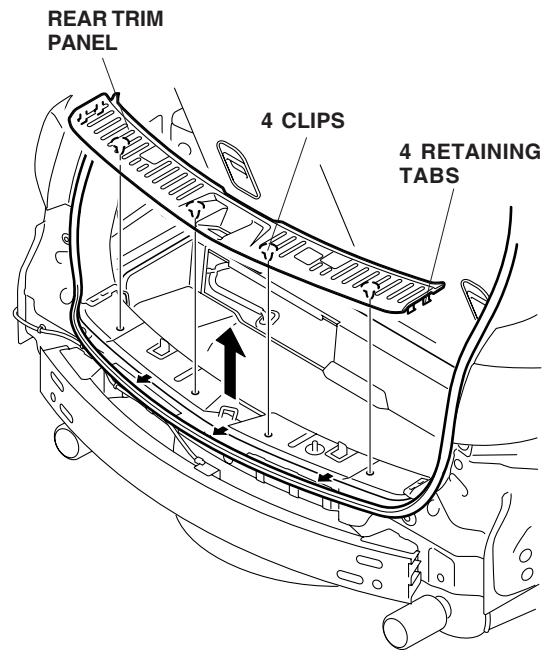

14. Remove the two cargo lid hinges (one self-tapping screw for each).

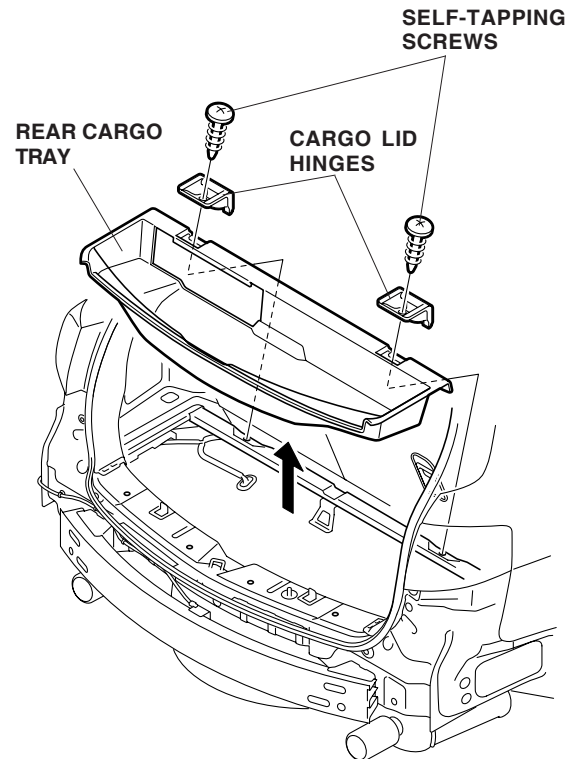

15. Remove the rear cargo tray.

## Routing the Subharness

16. Remove the left rear door side sill (three clips and two retaining tabs).

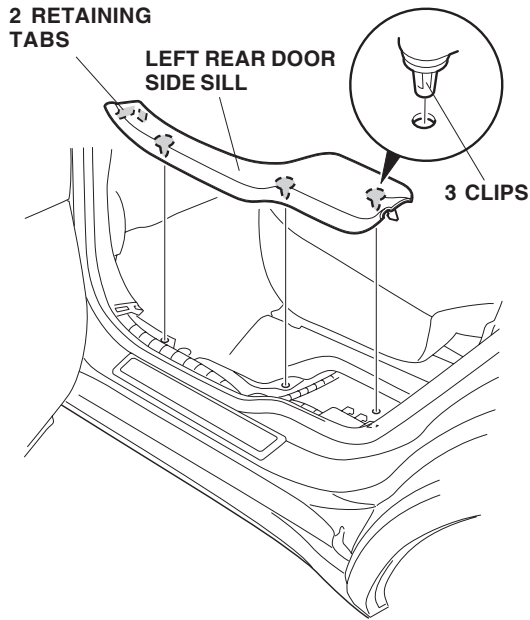

17. Release the two retaining tabs, spread the two seat bolt covers apart, and remove the seat bolt cover from the left third seat frame.

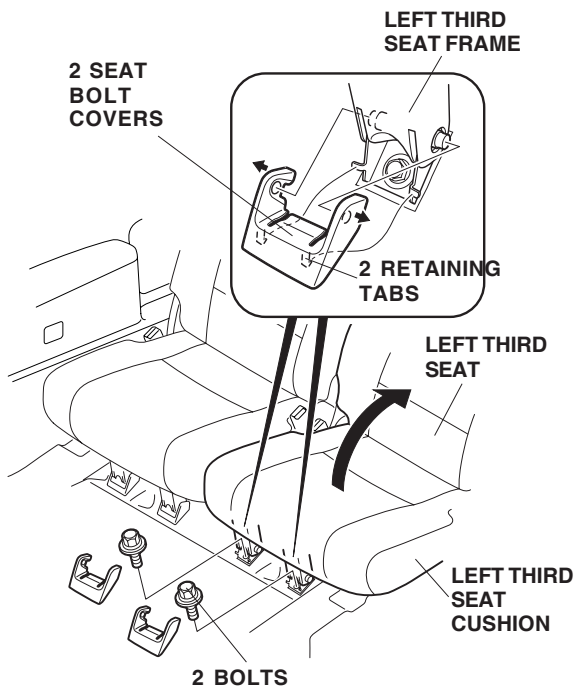

18. Remove the two bolts that fasten the left third seat to the floor. Raise the left third seat cushion.

19. Remove the four rear bolts that fasten the left third seat to the floor.

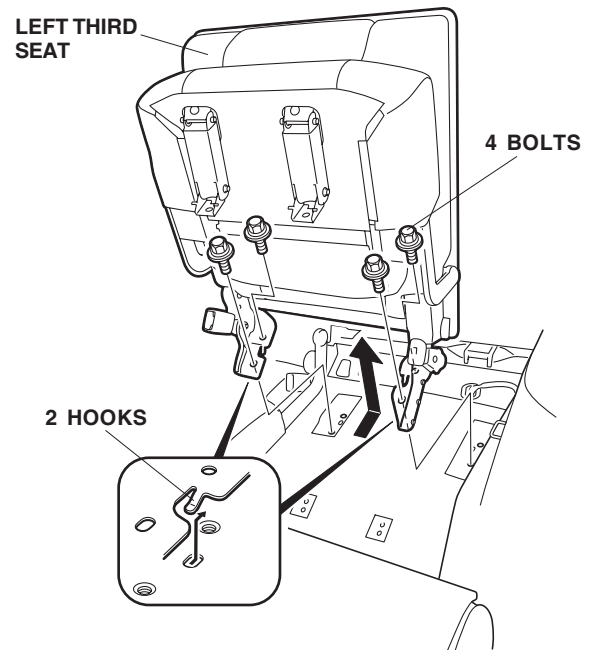

20. Release the two hooks by moving the left third seat rearward, then remove the left third seat.

- Using a small flat-tip screwdriver, open the lower tie-down hook covers. Remove the two tie-down hooks (one screw for each).

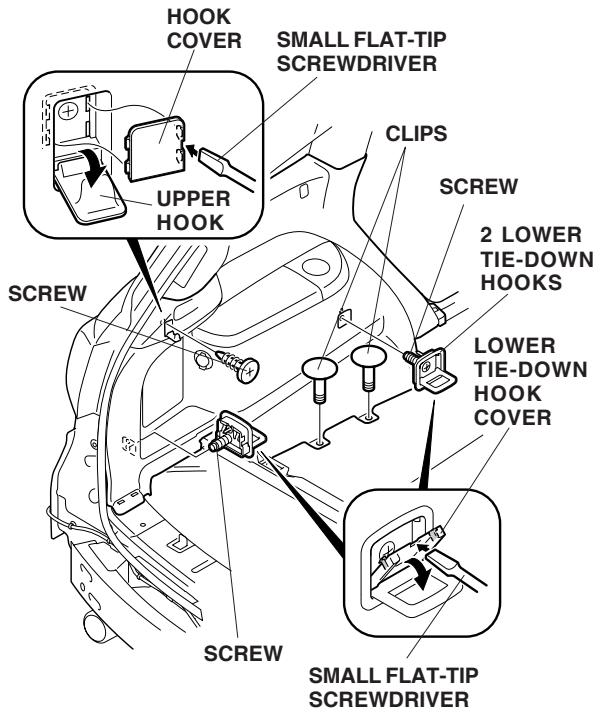

- Using a small flat-tip screwdriver, remove the hook cover from the upper hook. Remove the screw above the hook.
- Remove the two lower clips from the left cargo area side trim.

- Remove the tailgate weatherstrip and left rear door weatherstrip around the left cargo area side trim.

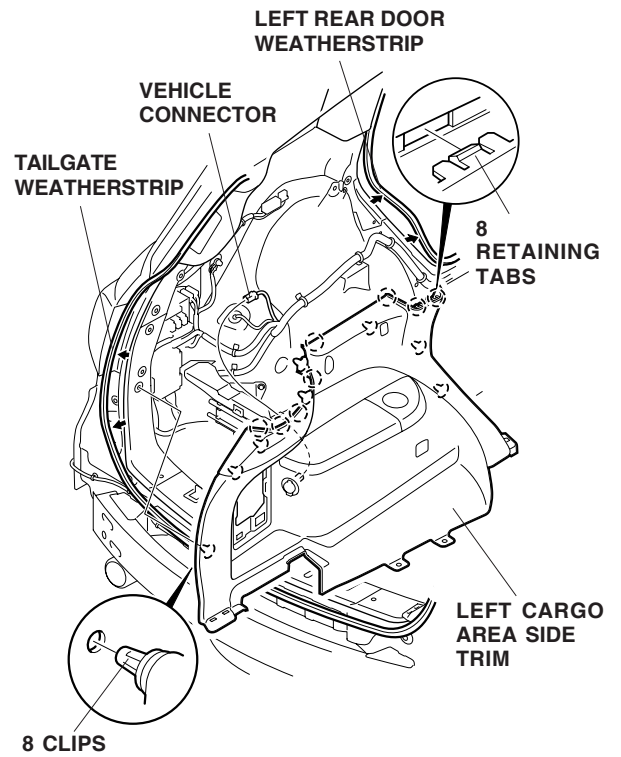

- Remove the left cargo area side trim (eight clips, eight retaining tabs, and unplug the vehicle connector).



26. Get the subharness. Using diagonal cutters, carefully cut and remove half of the grommet from the harness.

NOTE: Take care not to cut the subharness.

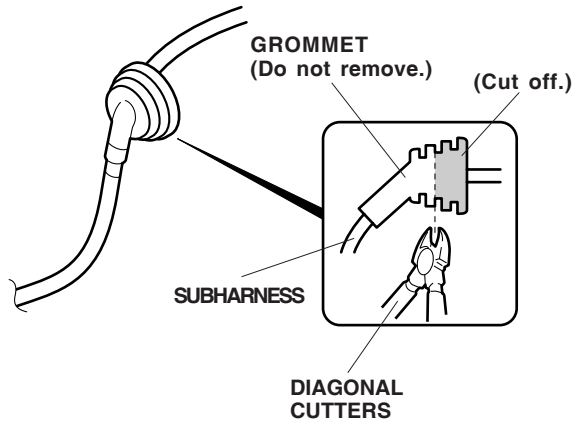

27. Locate and remove the body panel grommet from the left rear bumper area.

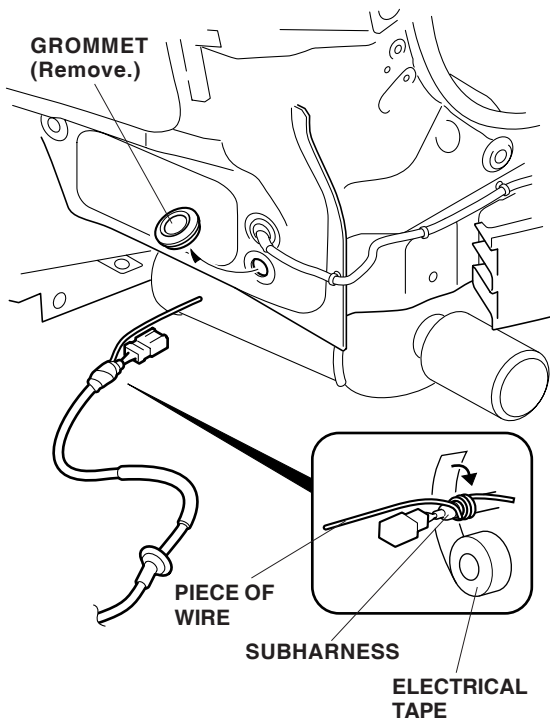

28. Tape a piece of wire to the subharness.

29. Route the subharness into the cargo area, and seat the rubber grommet into the body panel with the harness pointing down.

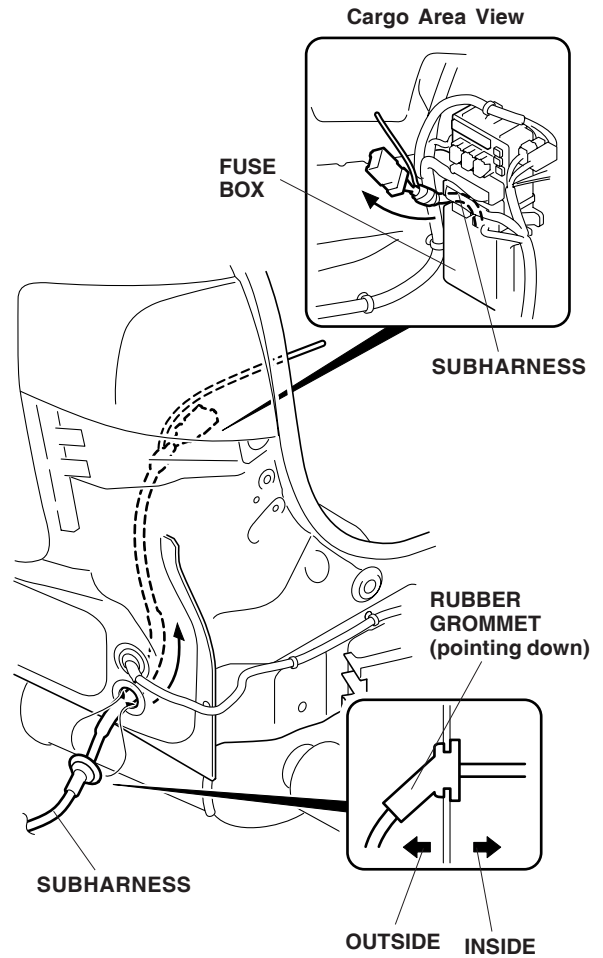

30. Remove the wire from the subharness.



31. Route the Subharness:

**With Vehicle Harness:** Route the subharness along the vehicle harness. Loosely secure the subharness to the vehicle harness with five wire ties.

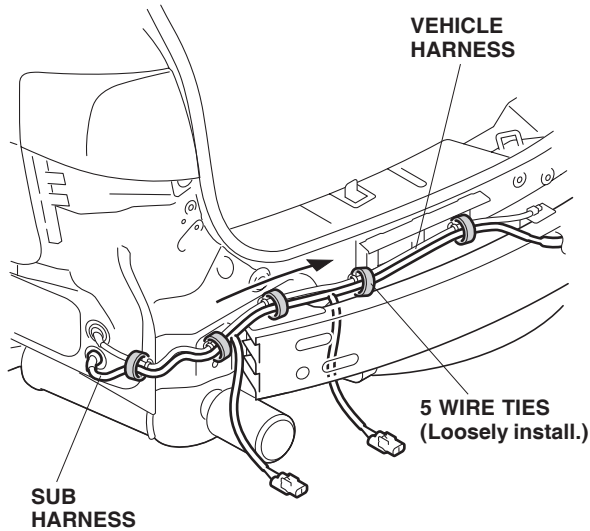

**Without Vehicle Harness:** Route the subharness along the bumper beam. Loosely install five wire ties with clips to the subharness and insert the clips into the five vehicle panel holes.

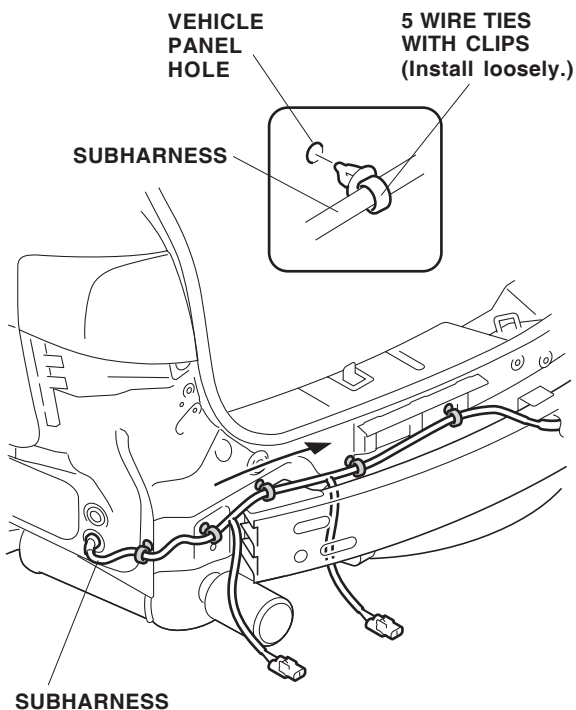

32. Install four clips to the subharness at the four thinner points on the subharness, then route the subharness along the rear bumper beam.

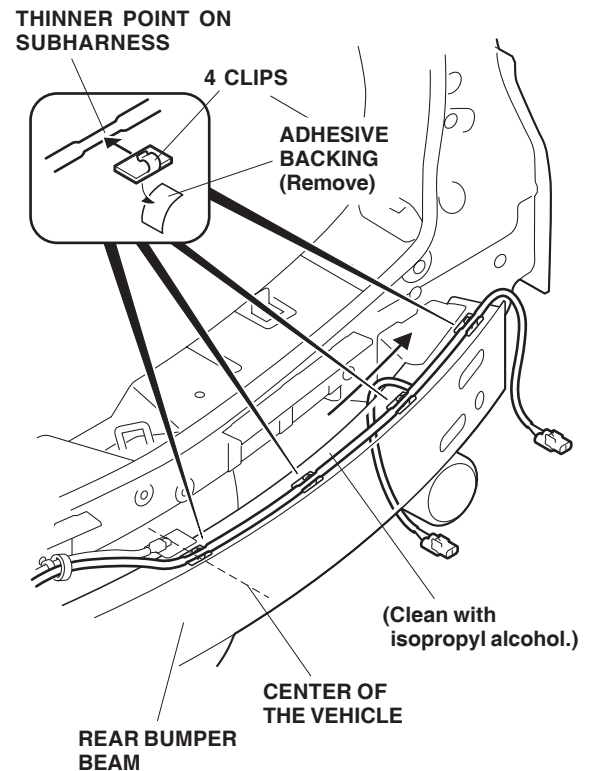

33. Using isopropyl alcohol on a shop towel, clean the bumper beam where the clips will attach.
34. Remove the adhesive backing from one of the four clips and attach it to the rear bumper beam so that the center of the clip aligns with the center of the vehicle. Attach the remaining three clips to the rear bumper beam with no slack in the subharness.
35. Tighten the wire ties you loosely secured in step 31.

## Routing the Backup Sensor Harness

36. Inside the cargo area, plug the backup sensor harness 6-pin connector into the subharness 6-pin connector.

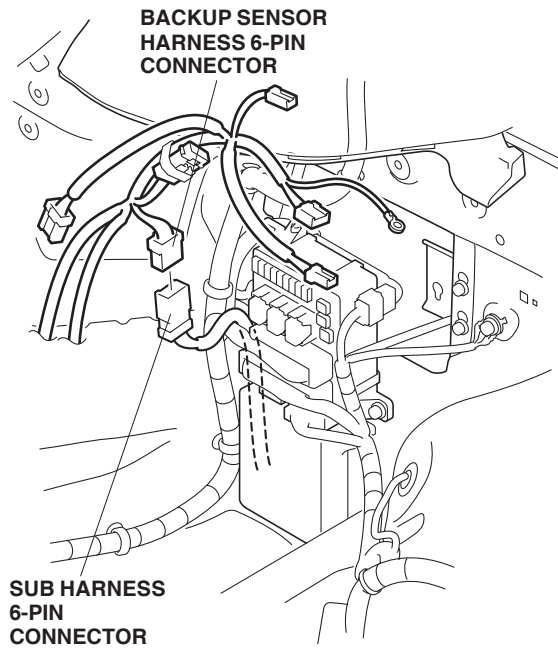

37. Remove the vehicle ground bolt from the ground terminal and attach the backup sensor harness ground terminal to the vehicle ground terminal using the vehicle ground bolt.

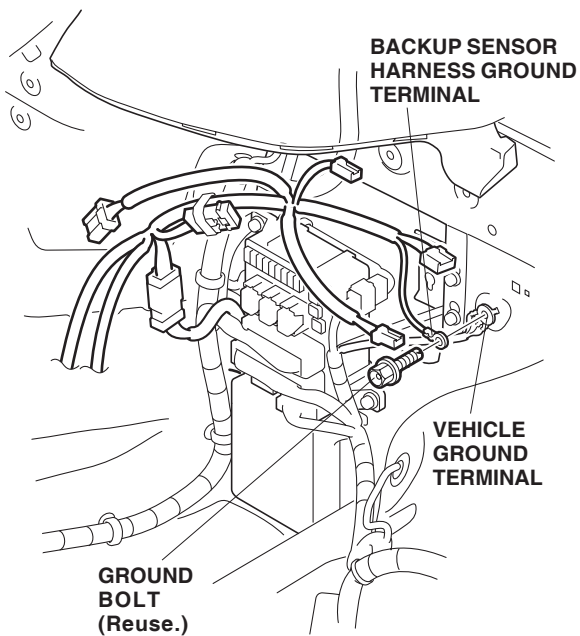

38. Attach the fuse label (BACKUP SENSOR 2A) to the backup sensor harness fuse case.

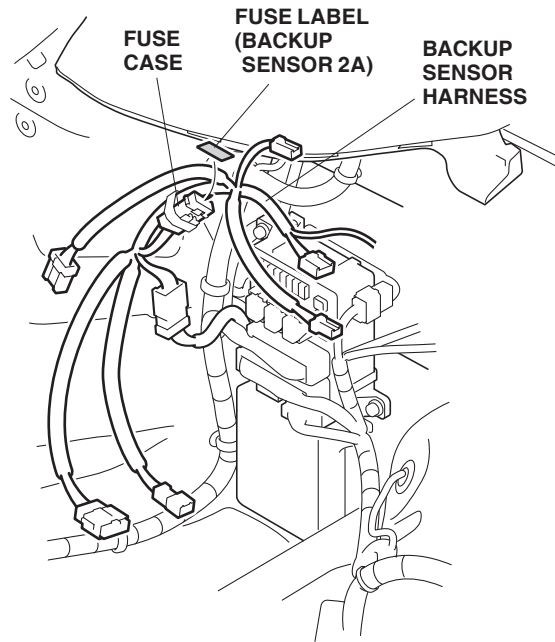

If the vehicle is equipped with a power tailgate, go to step 42. Otherwise, continue with step 39.

39. Unplug the vehicle 4-pin connector and plug the backup sensor harness 4-pin connectors in between.
41. Go to step 44.

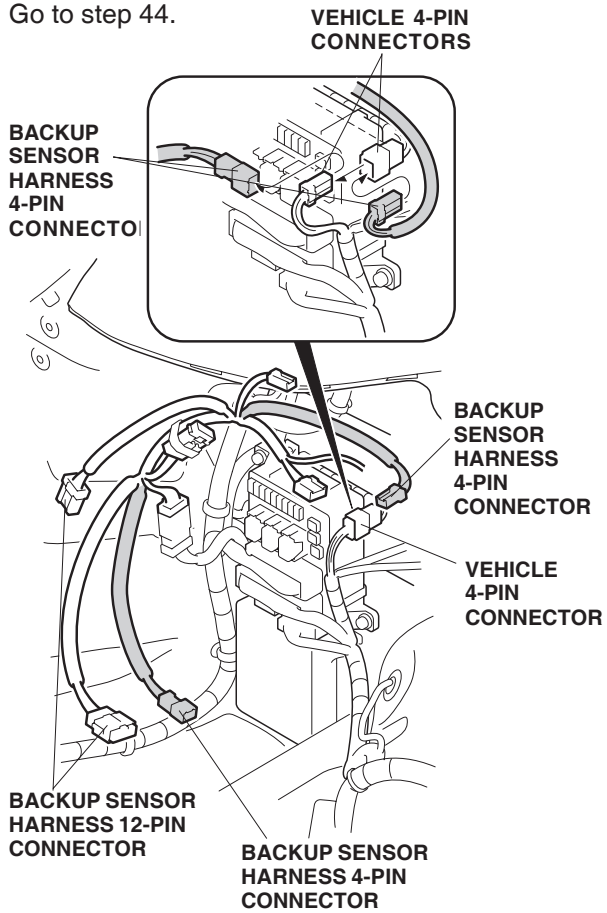

40. Plug the backup sensor harness 12-pin connectors into each other.

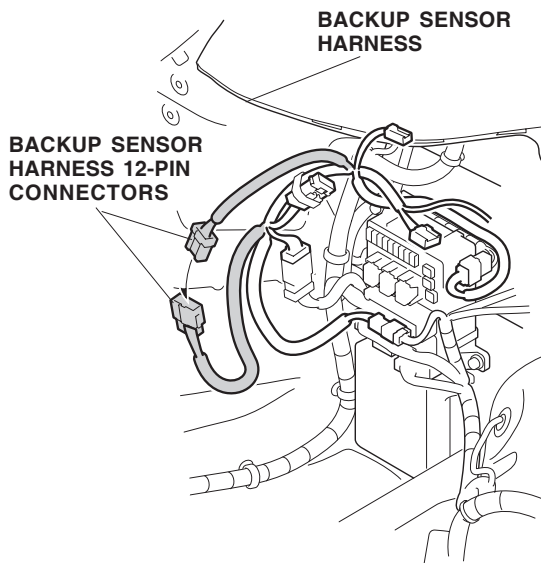

41. Go to step 44.

42. Unplug the vehicle 12-pin connector and plug the backup sensor harness 12-pin connectors in.

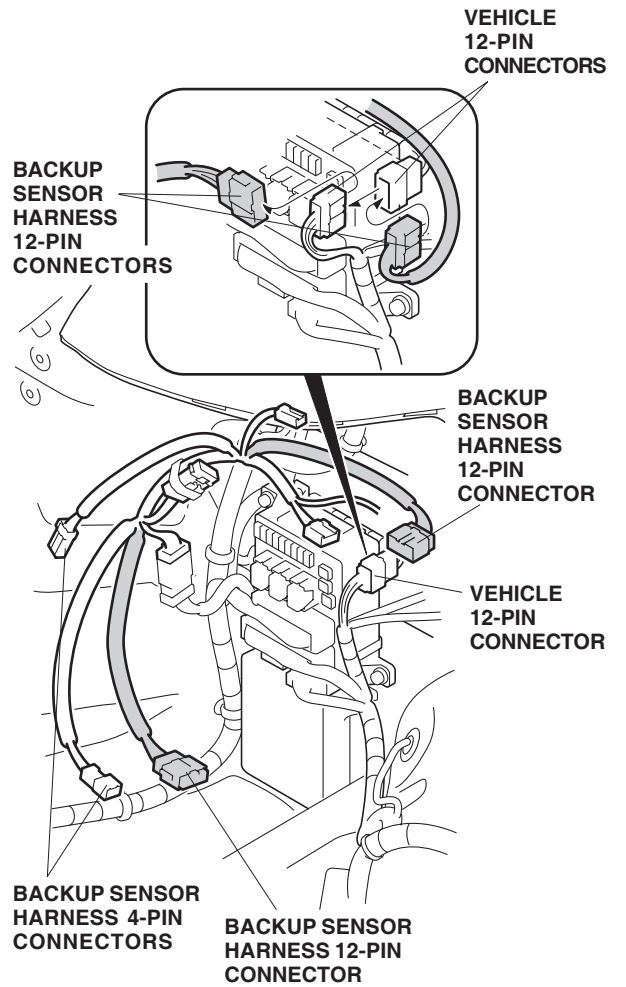

43. Plug the 4-pin connectors of the backup sensor harness into each other.

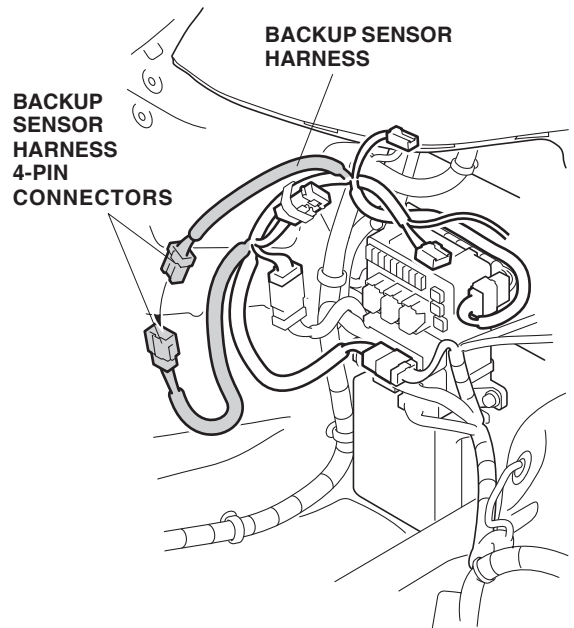

44. Slide the control unit onto the control unit bracket.

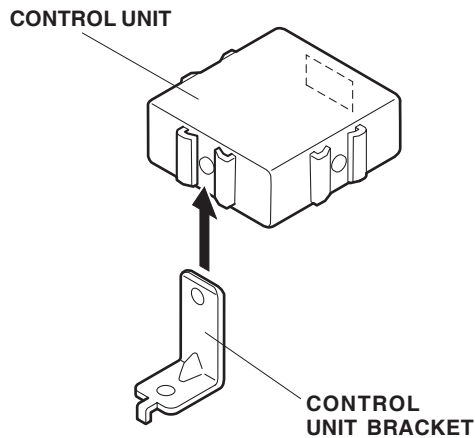

45. Insert the grommet into the hole in the vehicle panel.

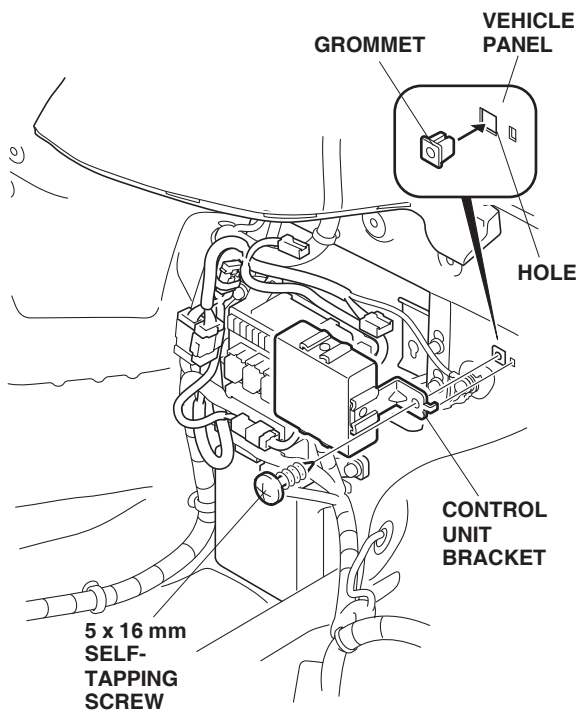

46. Position the control unit bracket on the grommet, and install the 5 x 16 mm self-tapping screw.

47. Plug the backup sensor harness 14-pin connector into the control unit.

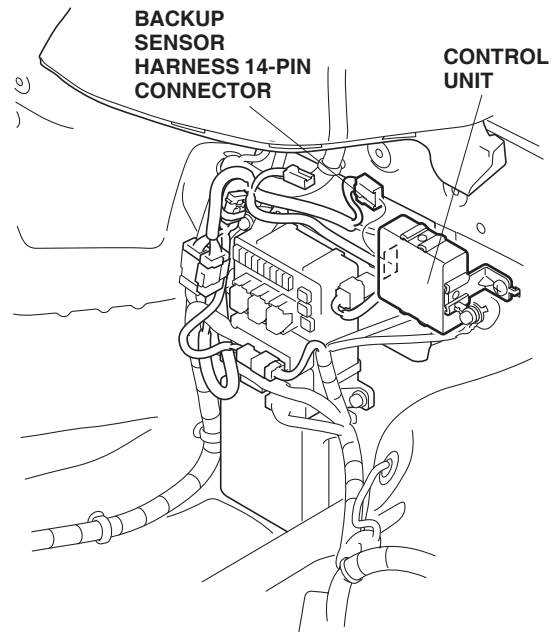

48. Using scissors, cut the EPT sealer as shown. Wrap the small piece of EPT sealer around the backup sensor 4-pin connector, and wrap the large piece of EPT sealer around the 12-pin connector.

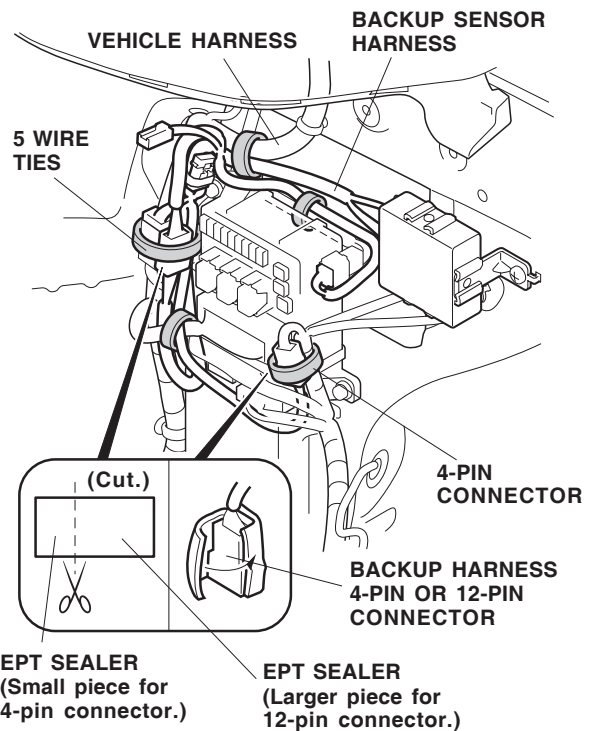

49. Secure the backup sensor harness to the vehicle harness using five wire ties.

## Installing the Buzzer

50. Using a tape measure and a felt-tip pen, measure and mark the inside of the left cargo area side trim as shown.

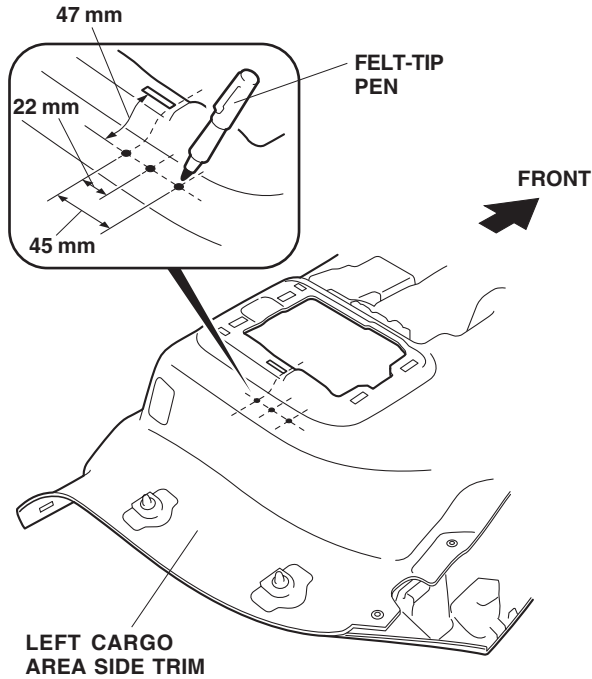

51. Using a pushpin, pierce through the left cargo area side trim at each of the three marks.

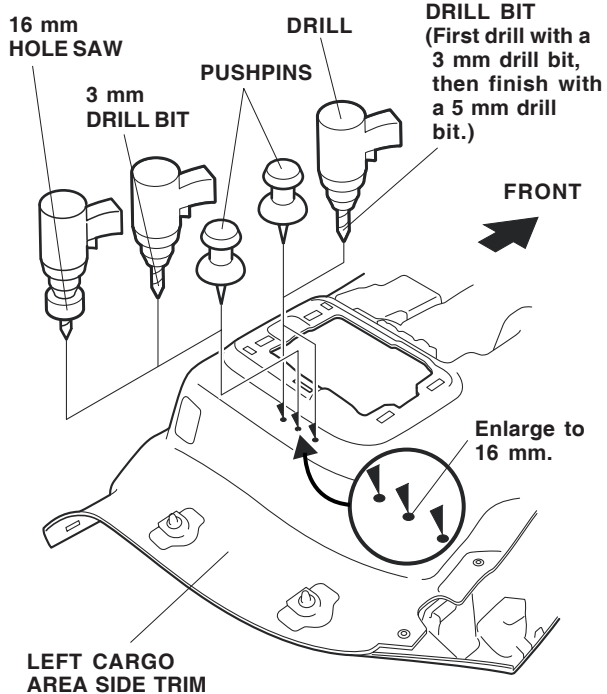

52. While wearing eye protection, drill a 3 mm hole through each of the three pierced points. Then drill the two outer holes with a 5 mm bit. Enlarge the center hole to 16 mm using a hole saw. Remove any burrs from the holes.

53. Route the buzzer harness through the 16 mm hole. With the buzzer switch facing up, install the buzzer with two 4 x 14 mm self-tapping screws with washers.

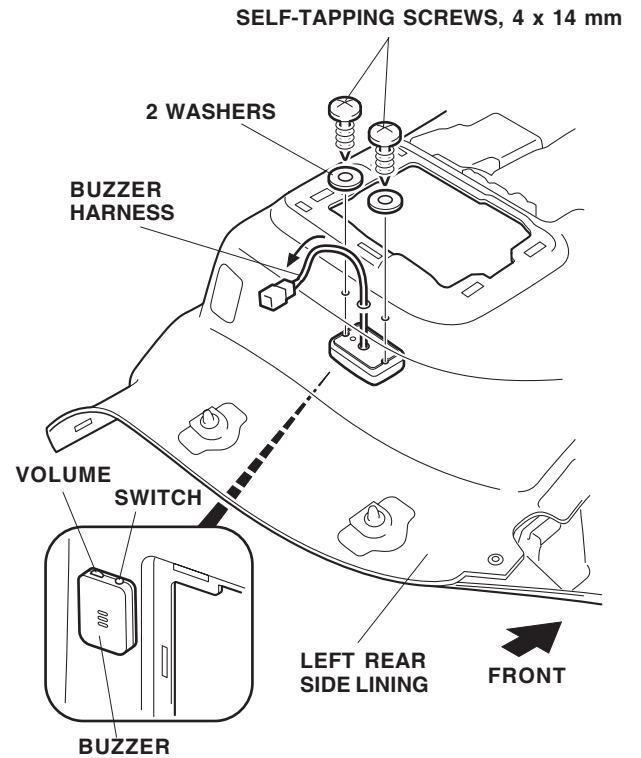

54. Connect the buzzer harness 2-pin connector to the backup sensor harness 2-pin connector. Secure the buzzer harness 2-pin connector to the vehicle harness using one wire tie.

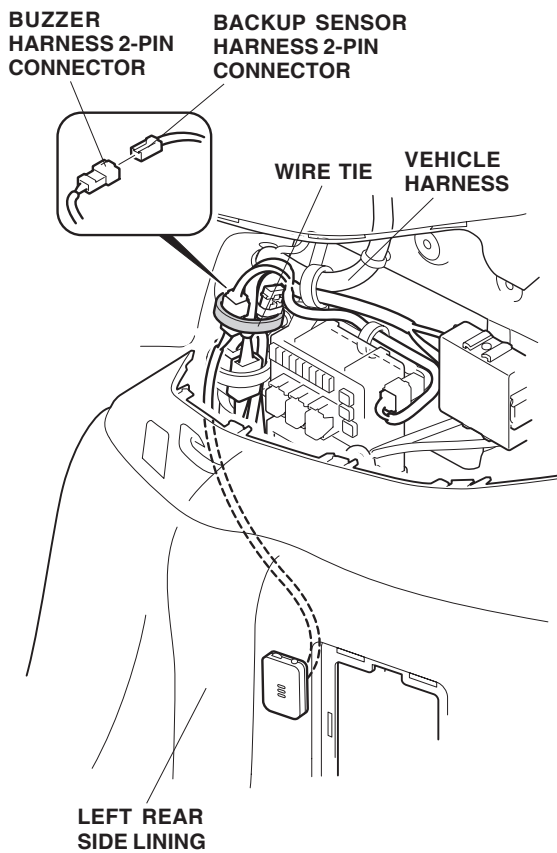

55. Plug in the vehicle connector, and reinstall the left cargo area side trim. Check that all clips and retaining tabs are installed securely.

56. With the help of an assistant, plug the backup sensor harness 2-pin connectors into the sensors, and reinstall the rear bumper. Check that all clips and retaining tabs are installed securely.

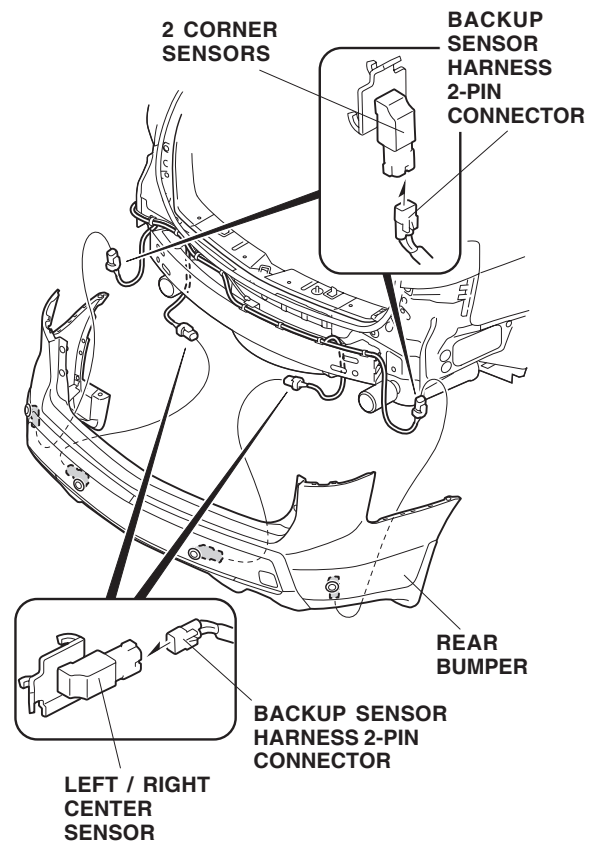

57. Check that all wire harnesses and cables are routed properly and that all connectors are plugged in.
58. Reinstall the third seat, torque the seat bolts to 41 to 53 N·m (30 to 39 lb-ft).
59. Reinstall all removed parts. Check that all clips and other fasteners are installed securely.
60. Reconnect the negative cable to the battery. Check that the electrical accessory and other electrical systems function properly.
61. Enter the client's radio anti-theft code, and reset the radio station presets.
62. Reset the clock.
63. Check that the backup sensors work properly as described in the Accessory User's Information Manual.

NOTE: When the battery is disconnected, the driver's window AUTO function is disabled.

64. Start the engine. Push down on the driver's window switch until the window is fully open.
65. Pull up on the driver's window switch to close the window completely, then hold the switch for 2 seconds or more.
66. Lower and raise the driver's window to check operation of the driver's window AUTO function.