



INSTALLATION INSTRUCTIONS

Accessory

REAR UNDER SPOILER

Application

2008 RL

Publications No.

BII 36372

Issue Date

MAY 2007

PARTS LIST

Rear under spoiler

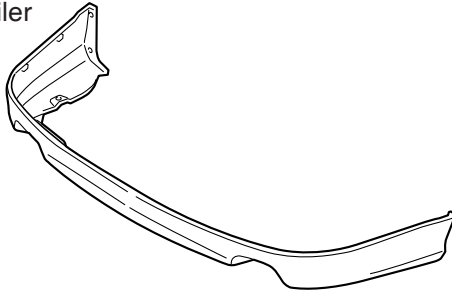

9 Square head bolts

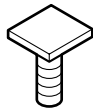

11 Washer-nuts



4 Self-tapping screws

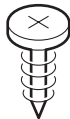

4 Spring nuts



2 Stepped bolts

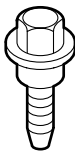

2 Clips

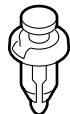

Template



TOOLS AND SUPPLIES REQUIRED

Phillips screwdriver

Flat-tip screwdriver

Ratchet

10 mm Socket

Drill

3 mm, 6 mm, 8 mm, and 10 mm Drill bits

Pushpin

File

Eye protection (face shield, safety goggles, etc.)

Utility knife

Hacksaw

Felt-tip pen

Blanket

Scale

INSTALLATION

Client Information: The information in this installation instruction is intended for use only by skilled technicians who have the proper tools, equipment, and training to correctly and safely add equipment to your vehicle. These procedures should not be attempted by "do-it-yourselfers."

NOTE:

- Be careful not to damage the body paint finish.
- Install this rear under spoiler kit only if the ambient air temperature is 60°F (15°C) or above.
- To allow the adhesive to cure, do not wash the car for 24 hours.

1. Open the trunk lid, and remove the rear bumper (four clips and two self-tapping screws).

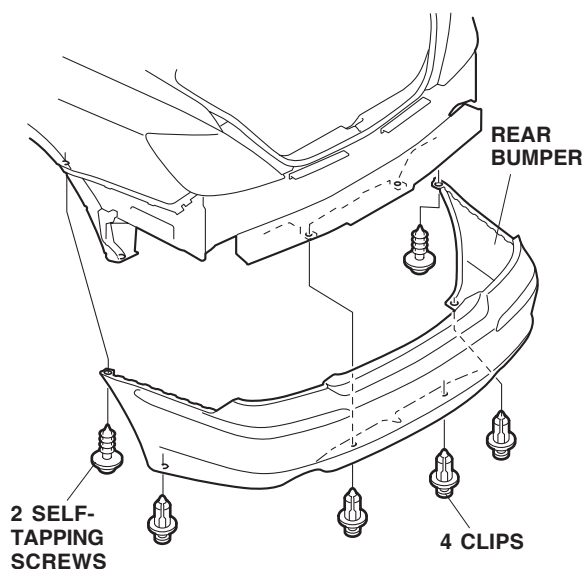

2. Position the template on the left side of the rear bumper by aligning them as shown. Using a pushpin, pierce the rear bumper as indicated by the arrow on the template.

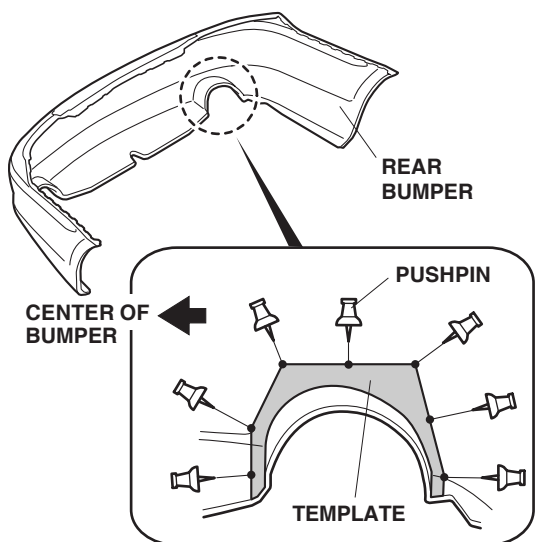

3. Remove the template. While wearing eye protection, drill a 10 mm hole at each of the seven pierced points on the rear bumper. First drill with a 3 mm drill bit, and finish with a 10 mm drill bit.

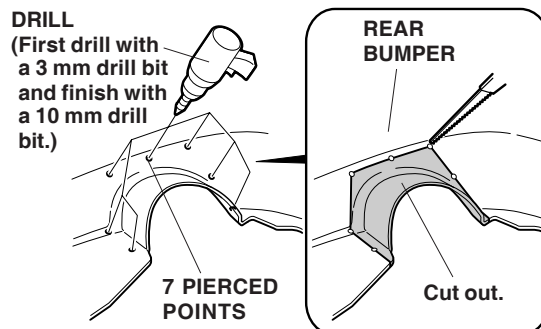

4. Draw the lines that connect the 10 mm holes in the rear bumper as shown, and cut off the rear bumper along the lines you just made.
5. Flip the template, and repeat steps 2 through 4 on the right side of the rear bumper.
6. Slide the two spring nuts onto the recesses at both ends of the rear bumper. Position the rear under spoiler on the rear bumper, and install the two self-tapping screws.

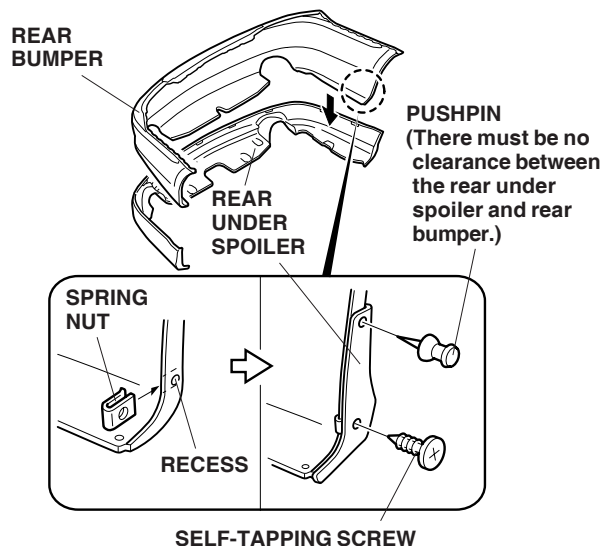

7. Using a pushpin, mark both ends of the rear bumper at the upper hole position of the rear under spoiler. There must be no clearance between the rear under spoiler and rear bumper. Remove the rear under spoiler.

- While wearing eye protection, drill a 6 mm hole at each of the two pierced points on both ends of the rear bumper. First drill with a 3 mm drill bit, and finish with a 6 mm drill bit.

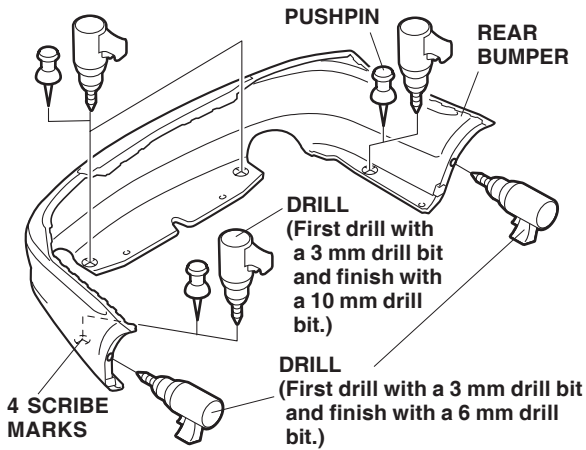

- Using a pushpin, pierce through the four scribe marks on the bottom of the rear bumper. While wearing eye protection, drill a 10 mm hole at each of the four pierced points. First drill with a 3 mm drill bit and finish with a 10 mm drill bit.
- Using a pushpin, pierce through the nine scribe marks on the rear bumper. While wearing eye protection, drill an 8 mm hole at each of the nine pierced points. First drill with a 3 mm drill bit and finish with an 8 mm drill bit.

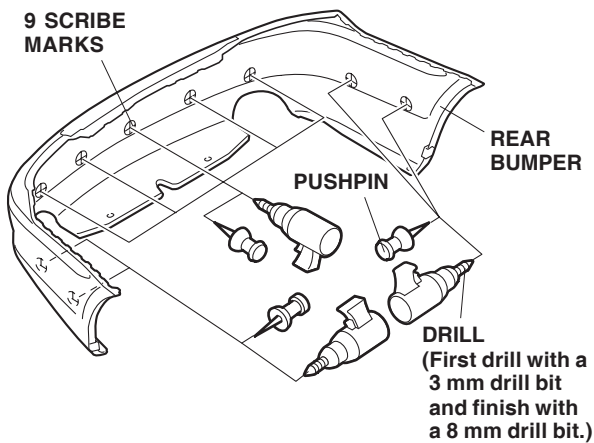

- Using a file, remove any burrs from all holes.

- Measure the left rear inner fender, and cut it out as shown. Remove the burrs from the edges of the hole.

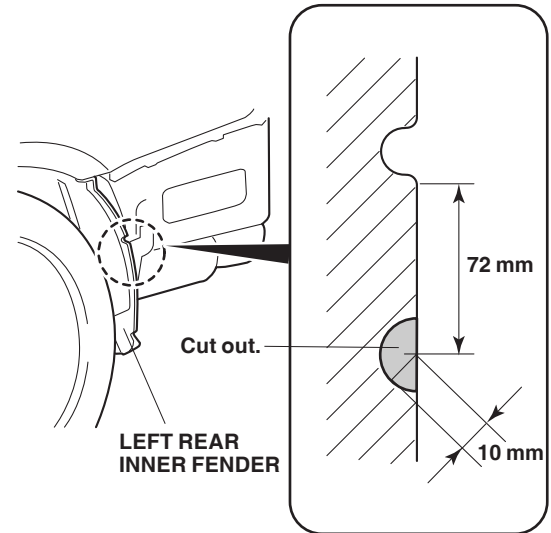

- Repeat step 12 on the right rear inner fender.
- Install the nine square bolts on the rear under spoiler.

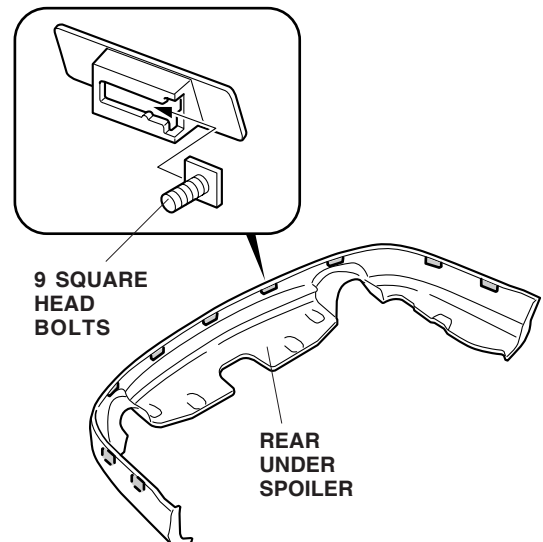

15. Slide the two spring nuts onto both ends of the rear bumper.

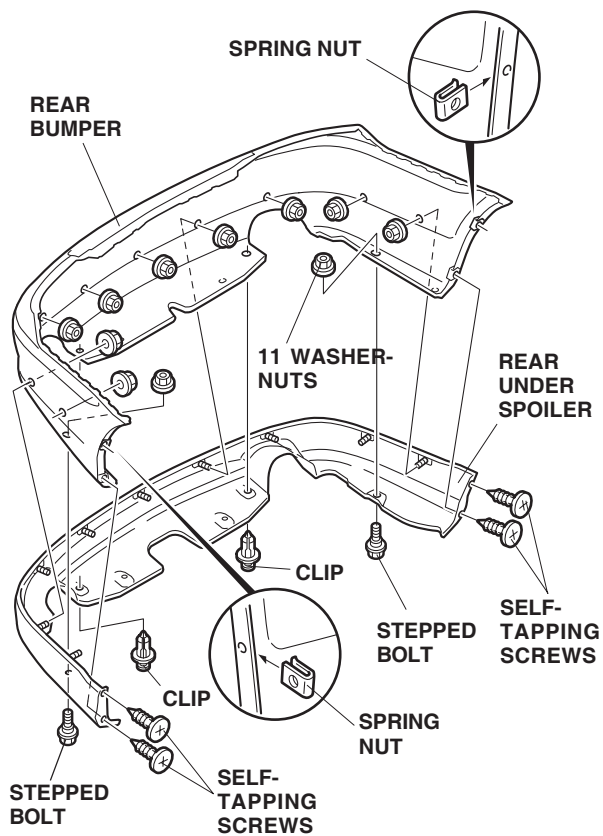

16. Position the rear under spoiler on the rear bumper, and install the 11 washer-nuts, two stepped bolts, two clips, and four self-tapping screws. Torque the washer-nuts to 2 N·m (1.5 lb-ft, 0.2 kgf·m).

17. Reinstall the rear bumper with the four clips and two self-tapping screws.

