



**ACURA**

**INSTALLATION  
INSTRUCTIONS**

Accessory

**RUNNING BOARD  
P/N 08L33-STK-200**

Application

**2008 RDX**

Publications No.

**BII 37440**

Issue Date

**JUL 2007**

**PARTS LIST**

Right running board

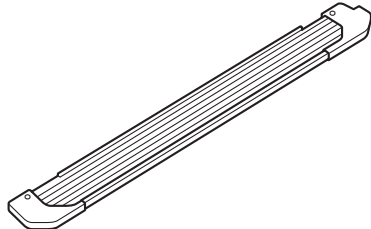

Left running board

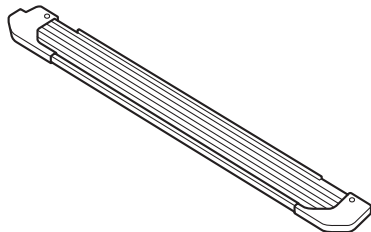

4 Brackets A

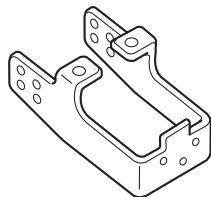

4 Brackets B

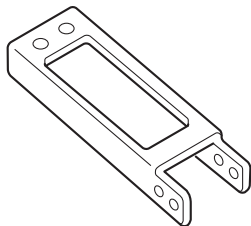

16 Flange nuts, 8 mm



44 Flange bolts, 8 x 20 mm

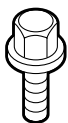

**TOOLS AND SUPPLIES REQUIRED**

- Ratchet
- 13 mm Socket
- Extension
- 13 mm Combination wrench
- Blanket

**INSTALLATION**

**Client Information:** The information in this installation instruction is intended for use only by skilled technicians who have the proper tools, equipment, and training to correctly and safely add equipment to your vehicle. These procedures should not be attempted by “do-it-yourselfers”.

**NOTE:**

- Thoroughly clean the bottom of the body from the rear of the front wheels forward to the front of the rear wheels.
- Be careful not to damage the body paint finish. To prevent damage, place a blanket under the running board during the installation.
- These instructions show the left running board being installed; the same procedure applies to installing the right running board.

### Front Bracket Assembly

1. Using brackets A and B loosely assemble the two bracket assemblies, and install the four flange bolts and four flange nuts. Make sure to use the lower holes in bracket A.

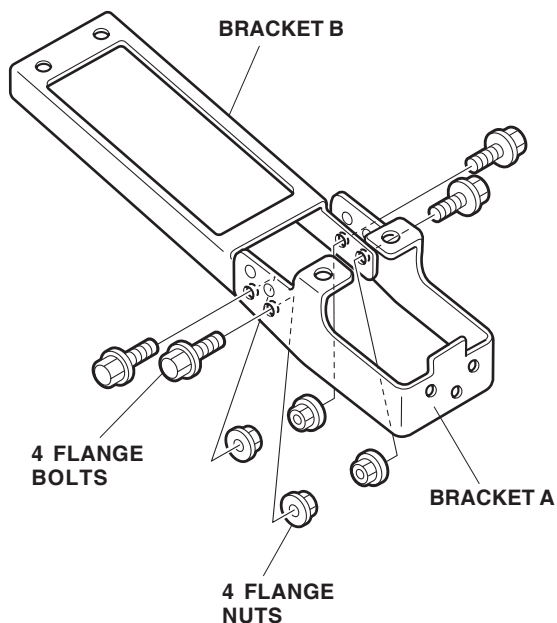

### Rear Bracket Assembly

2. Using brackets A and B loosely assemble the two rear bracket assemblies, and install the four flange bolts and four flange nuts. Make sure to use the upper holes in bracket A.

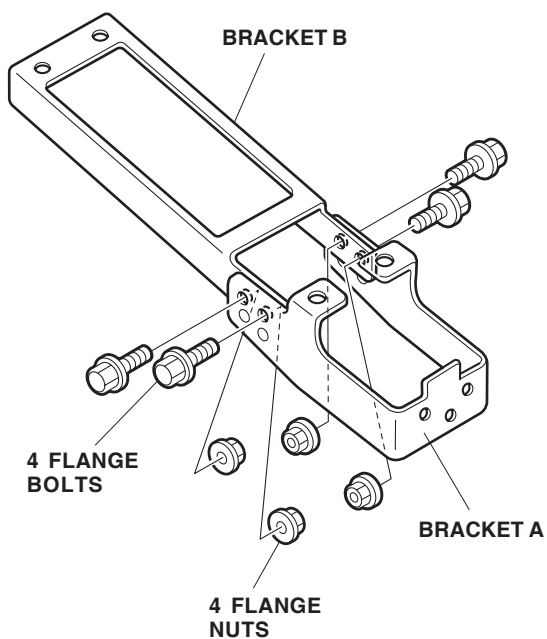

3. Position the front bracket assembly and rear bracket assembly at the respective installation positions of the vehicle. Install the front and rear bracket assemblies on the vehicle using the four flange bolts. Torque the flange bolts to 27 N·m (20 lb-ft).

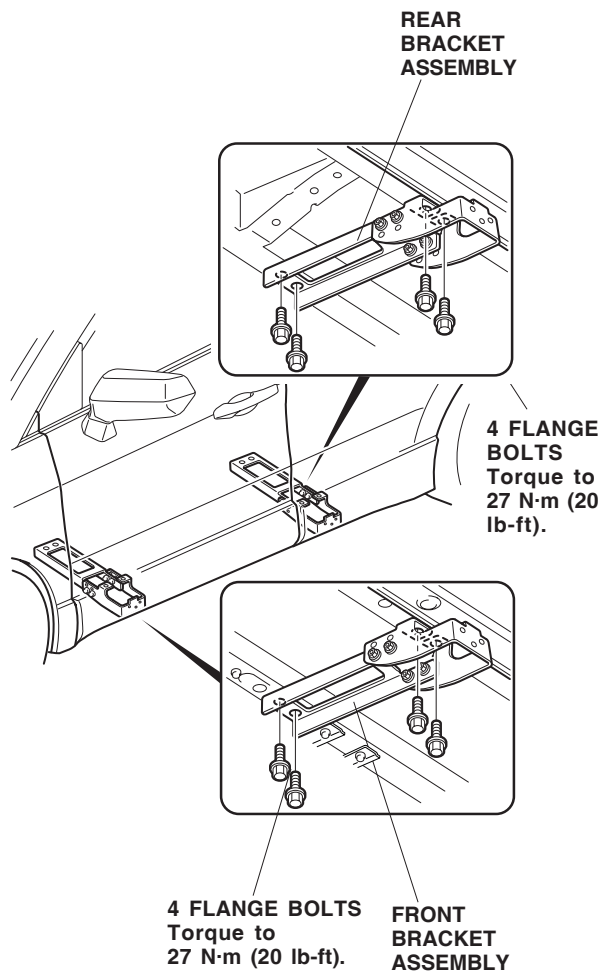

- Place the left running board (marked driver's side) on the hook of each bracket. Align the holes in the left running board with the holes in the brackets and install the left running board using the six flange bolts. Torque the flange bolts to 27 N·m (20 lb-ft).

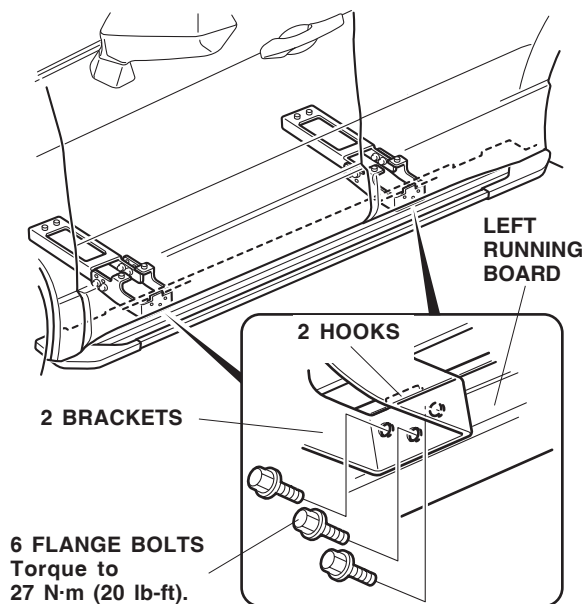

- Torque the flange bolts and flange nuts (from steps 1 and 2) to 27 N·m (20 lb-ft).

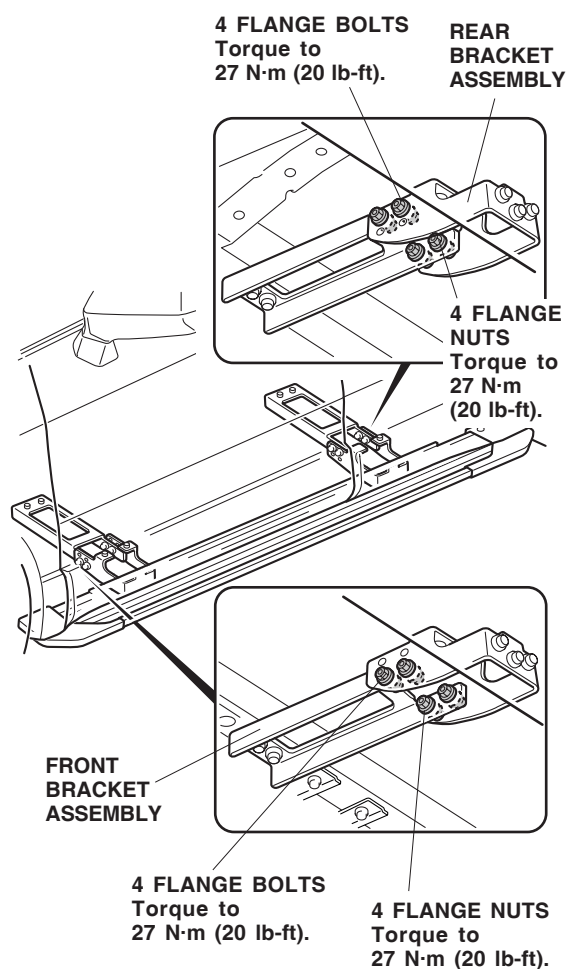

- Check that all the flange bolts and nuts are tightened securely.
- Repeat steps 1 thru 6 to install the right running board on the right side of the vehicle.