

ACURA INSTALLATION INSTRUCTIONS

Accessory	Application	Publications No.
ENGINE BLOCK HEATER P/N 08T44-SJA-200	2008 RDX	BII 37427
		Issue Date
		JUL 2007

PARTS LIST

NOTE: Installation of the engine block heater requires that the vehicle be raised on a hoist and that the coolant be replaced. This installation should be done only by an authorized dealer.

Engine block heater

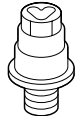

Aluminium washer



Heater harness

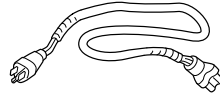

Protective cap

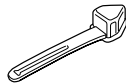

15 Wire ties
(7 not used)



5 Wire ties with clip

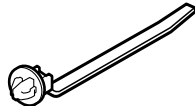

TOOLS AND SUPPLIES REQUIRED

Philips screwdriver
Flat-tip screwdriver
Ratchet
19 mm, 24 mm Socket
Torque wrench
Drill
Drill bit (3 mm, 5 mm)
Wrench (1/2 inch)
10 mm Combination wrench
Diagonal cutters
Drain pan
Coolant (Genuine Antifreeze/Coolant only, in a 50/50 mixture with water)
Blanket/Fender cover
Tape measure

NOTE:

- Always use Honda Antifreeze/Coolant. Using a non-Honda coolant can result in corrosion, causing the cooling system to malfunction or fail.
- To avoid burning out the element, do not operate the engine block heater before it is installed in the vehicle and before you add coolant.

INSTALLATION

Client Information: The information in this installation instruction is intended for use only by skilled technicians who have the proper tools, equipment, and training to correctly and safely add equipment to your vehicle. These procedures should not be attempted by “do-it-yourselfers.”

1. Make sure you have the anti-theft code for the radio and navigation system, then write down the audio presets.
2. Open the hood, and allow the engine and all cooling system components to cool down.
3. Place a clean drain pan under the radiator drain plug, then remove the drain plug from the bottom of the radiator to drain the coolant. Remove the radiator cap to increase the flow.

NOTICE Radiator coolant will damage paint. Quickly rinse any spilled coolant from painted surfaces.

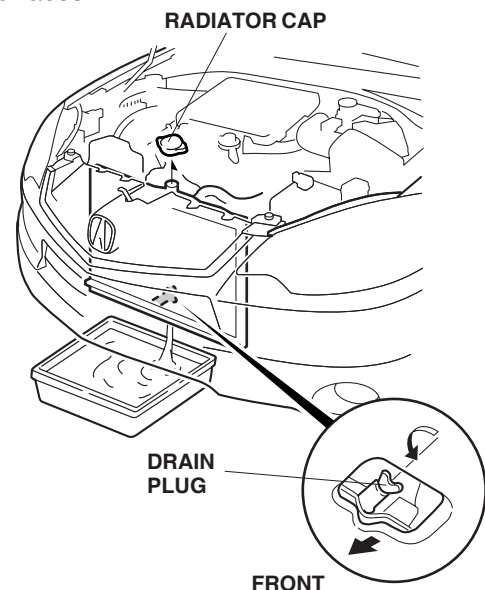

- Remove the four clips and two long clips from the front bulkhead cover.

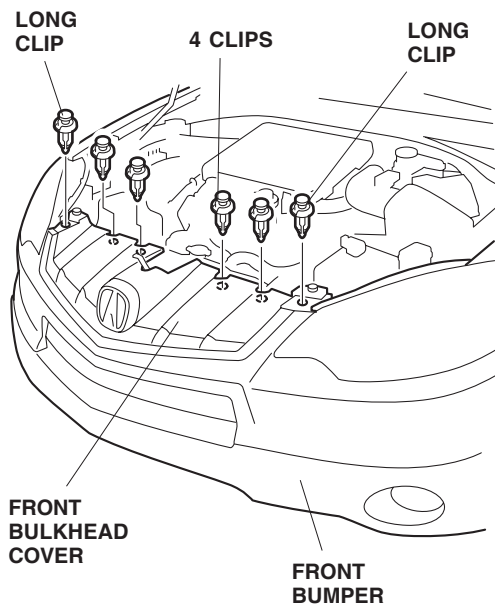

- Remove the front bumper (six self-tapping screws, three clips, four long clips and unplug the fog light connectors).

- Have an assistant help you when removing and installing the front bumper.
- Place the front bumper on blanket/fender cover to prevent damage.

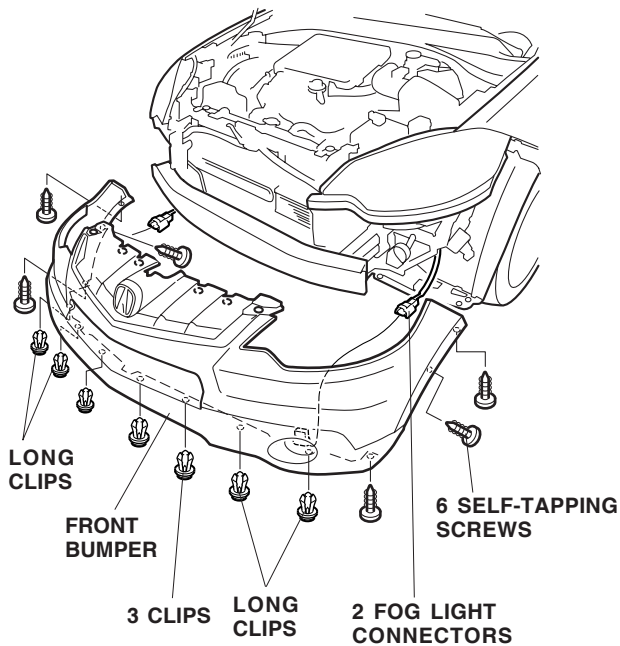

- Remove the air duct cover (two clips and one pin).

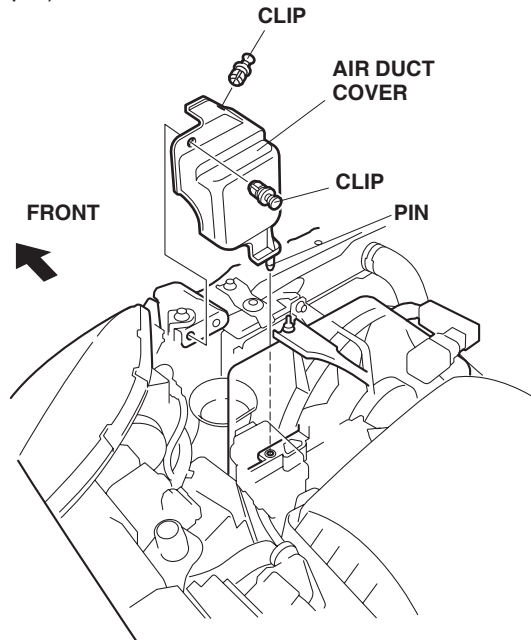

- Disconnect the negative (-) cable from the battery, open the positive cable cover and disconnect the positive (+) cable from the battery. Loosen the two battery holder nuts and remove the battery holder.

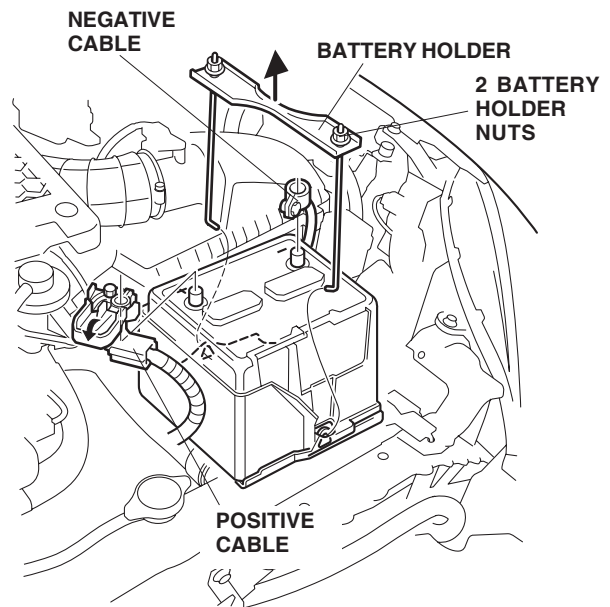

8. Remove the battery cover, battery and battery box.

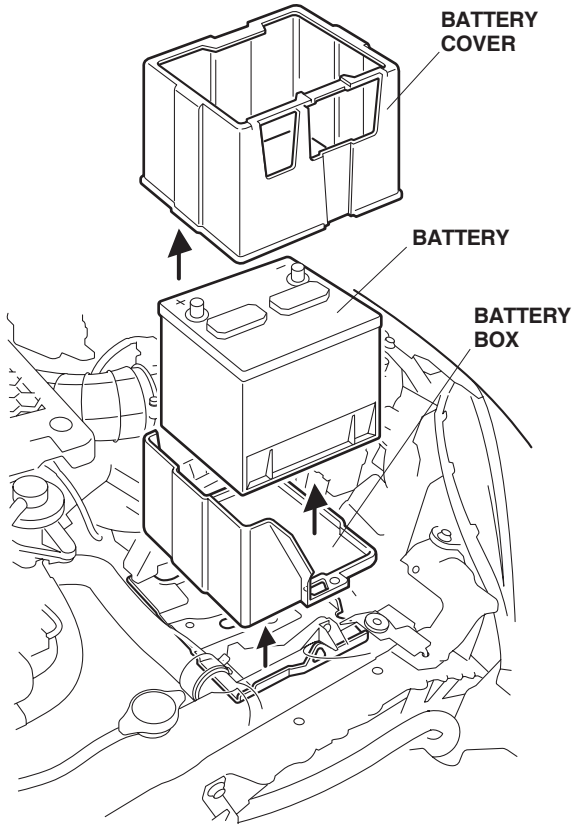

9. Remove the vehicle harness from the vehicle bracket (two retaining tabs).

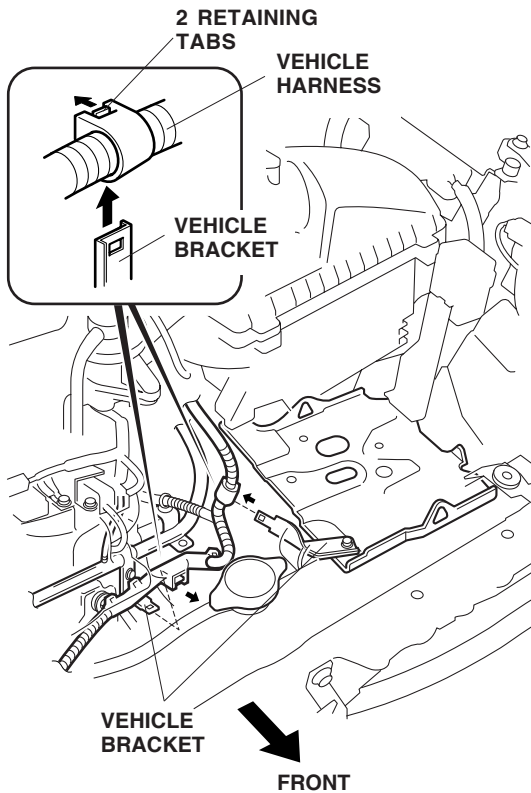

10. Remove the vehicle bracket from the battery tray (one vehicle bolt).

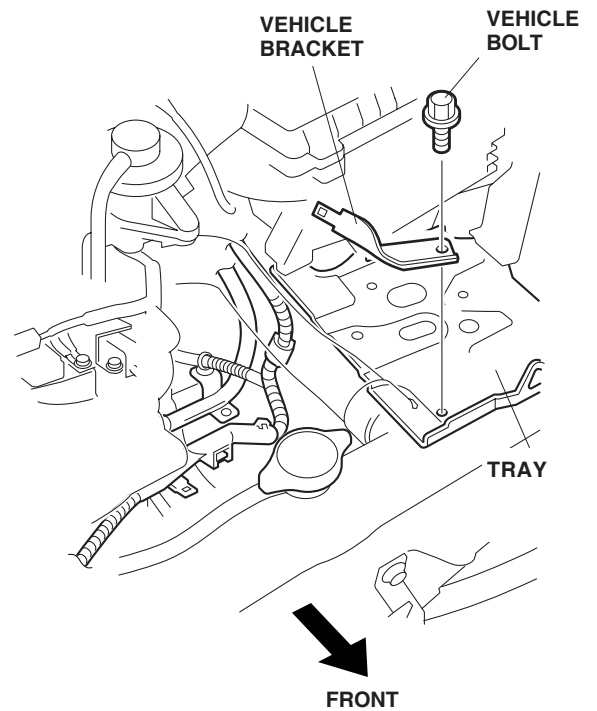

11. Locate and remove the engine block drain bolt and washer. Coolant remaining in the engine jackets flows out of the bolt hole when the bolt is removed. (Retain the bolt and washer in case the block heater is removed.)

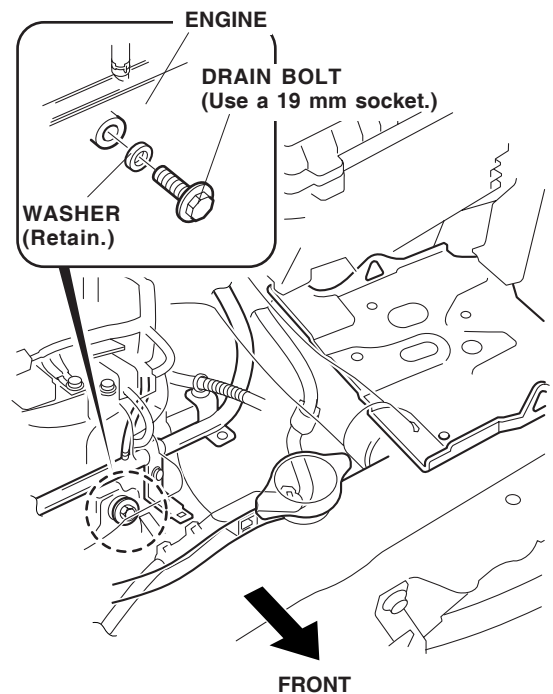

12. Install the new aluminum washer and the engine block heater in to the bolt hole using a 24 mm socket and torque wrench. Torque the engine block heater to 60 N·m (44 lbf·ft).

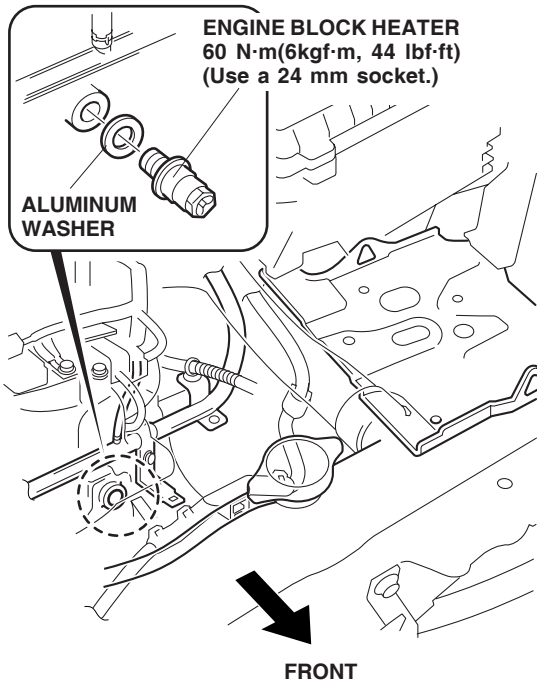

13. Install five wire ties with clip to the heater harness at the measurements shown.

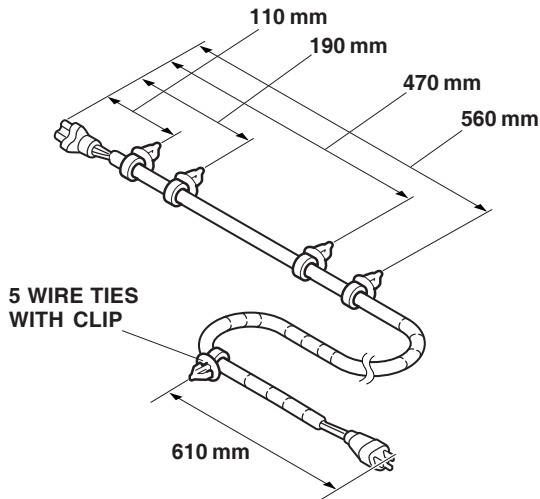

14. Plug the heater harness connector into the engine block heater.

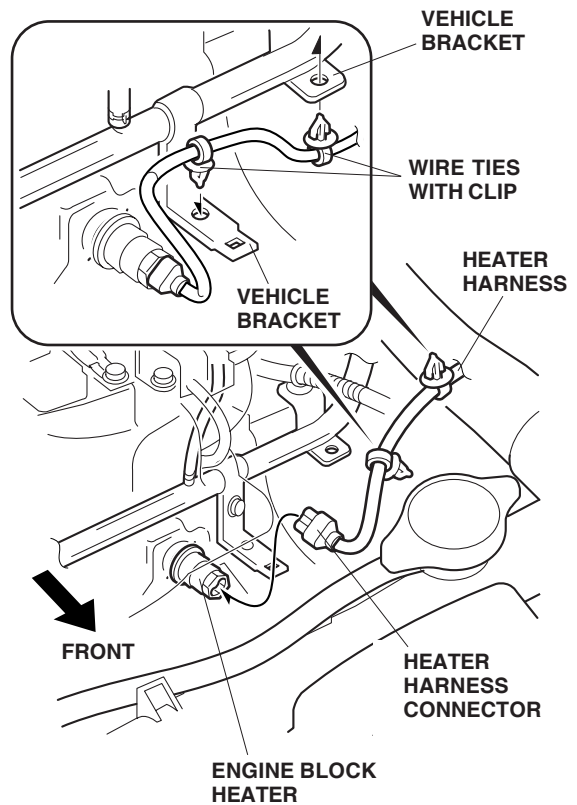

15. Attach the first and the second wire ties with clip, closest to the heater harness connector, to the vehicle bracket.

16. Attach the third and the fourth wire ties with clip, to the two holes under the battery tray.

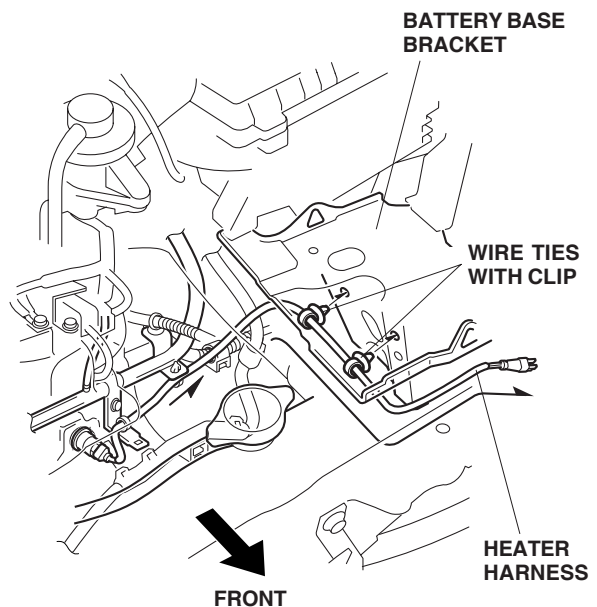

- Route the heater harness through the front bulkhead opening.

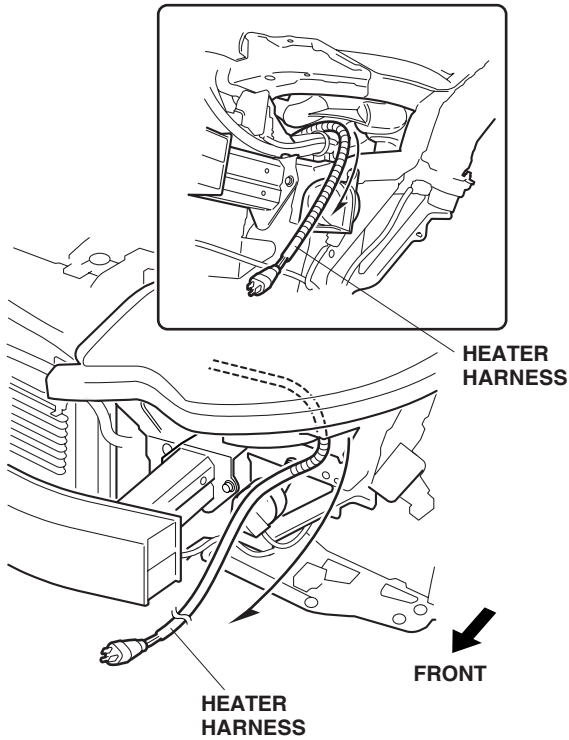

- Secure the fifth wire tie with clip, that you installed on the heater harness, to the vehicle frame.

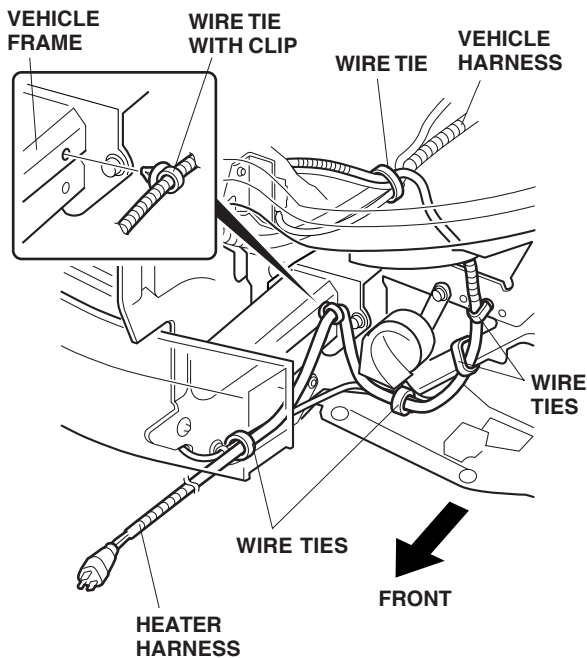

- Secure the heater harness to the vehicle harness and the vehicle frame using five additional wire ties.
- Near the engine block heater secure the heater harness to the vehicle harness with one additional wire tie.

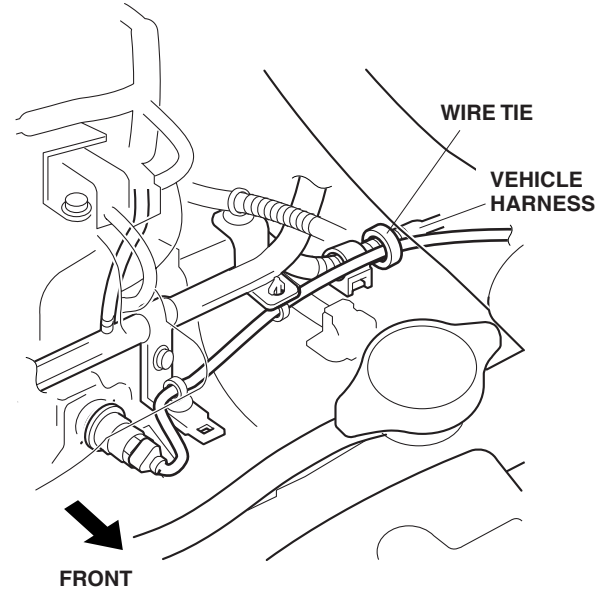

- On the inside of the front bumper, locate the two presets. While wearing eye protection, drill two 5 mm holes, through the marked points on the front bumper lower grille. First drill with a 3 mm drill bit, and finish with a 5 mm drill bit.

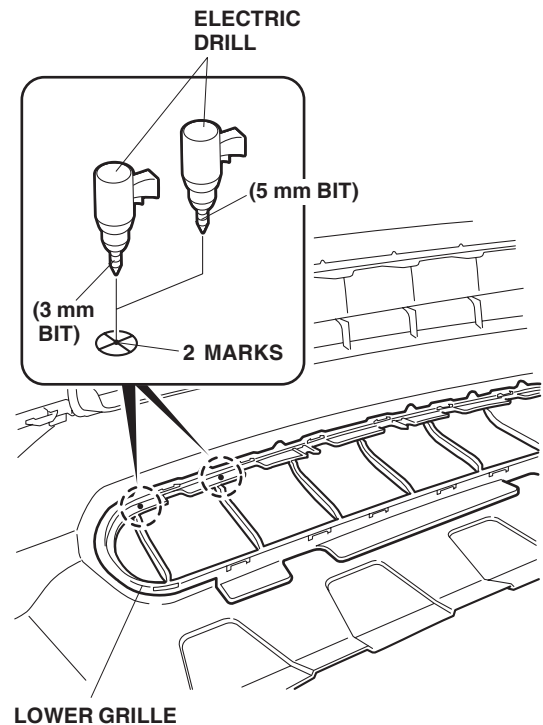

22. Reinstall the front bumper on the vehicle. Secure the heater harness to the front bumper lower grille using the two wire ties.

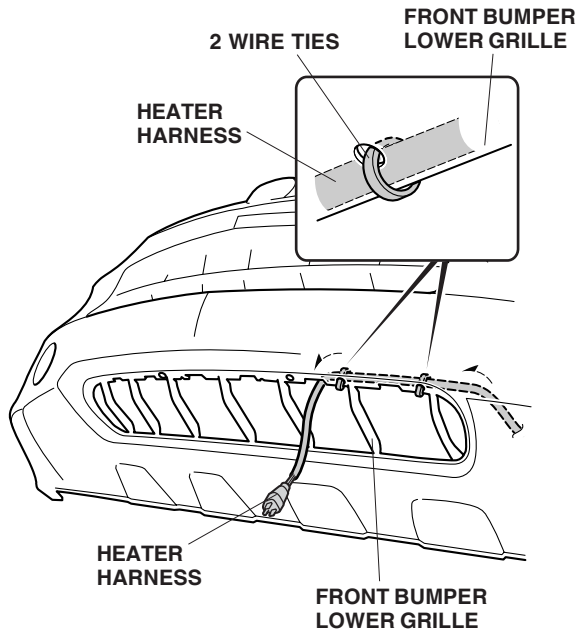

23. Attach the protective cap to the front bumper lower grille, and plug the heater harness connector into the protective cap.

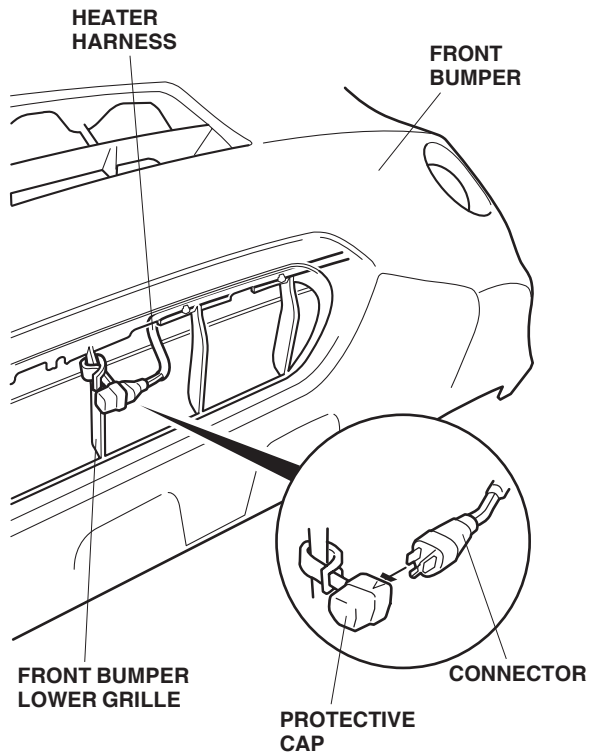

24. Reinstall all removed parts.
25. Reinstall the radiator drain plug.
26. Fill the system with the recommended coolant. Follow the instructions described in the service manual to fill and bleed the cooling system.
27. Check the coolant reservoir for correct level and check the cooling system for signs of leakage. Repair as necessary.
28. Check that the heater harness is routed properly and all connectors are plugged in.
29. Put the drain bolt (removed in step 11) in the glove box.
30. Reconnect the negative cable to the battery.
31. Enter the client's radio anti-theft code, and reset the radio station presets.
32. Reset the clock.

NOTE: When the battery is disconnected, the driver's window AUTO function is disabled.

- Start the engine. Push down on the driver's window switch until the window is fully open.
- Pull up on the driver's window switch to close the window completely, then hold the switch for 2 seconds or more.
- Lower and raise the driver's window to check operation of the driver's window AUTO function.