



ACURA INSTALLATION INSTRUCTIONS

Accessory	Application	Publications No.
REAR LOWER TRIM	2008 MDX	BII 37601
		Issue Date
		AUG 2007

NOTE: The rear lower trim cannot be installed on a vehicle equipped with a trailer hitch.

PARTS LIST

Rear lower trim

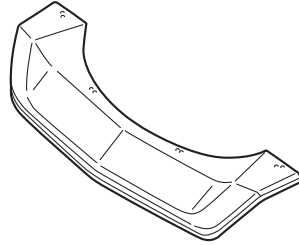

4 Bolts



TOOLS AND SUPPLIES REQUIRED

- Phillips screwdriver
- Flat-tip screwdriver
- Drill
- 3 mm and 10 mm Drill bits
- Pushpin
- Eye protection (safety goggles, face shield, etc.)
- 10 mm Combination wrench
- Ratchet
- 10 mm Socket
- Blanket
- File

INSTALLATION

Client Information: The information in this installation instruction is intended for use only by skilled technicians who have the proper tools, equipment, and training to correctly and safely add equipment to your vehicle. These procedures should not be attempted by "do-it-yourselfers."

1. Open the tailgate. With the help of an assistant, remove the rear bumper (4 caps, 4 bolts, 4 clips, and 12 self-tapping screws). Set the bumper on a blanket.

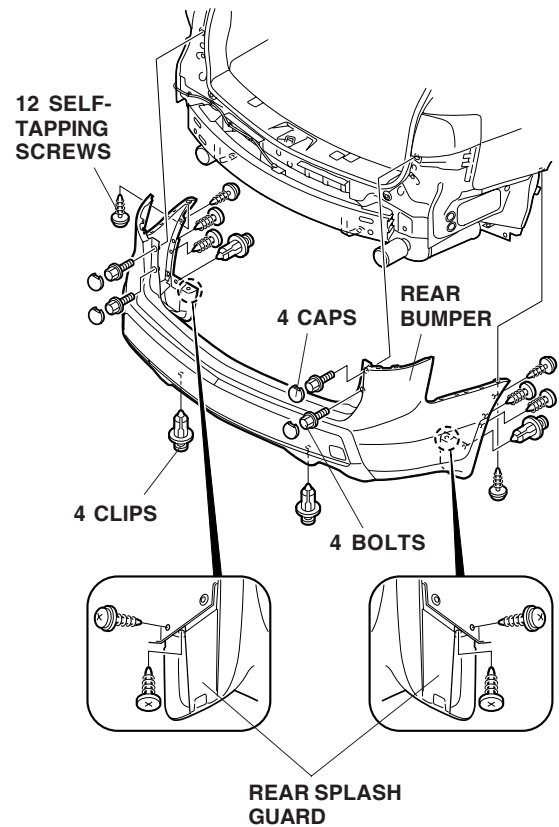

2. On the inside of the rear bumper, locate the four preset marks. Using a pushpin, pierce a hole through each mark.

NOTE: There are 3 additional marks that are not used for the rear lower trim. Be sure to locate the correct marks.

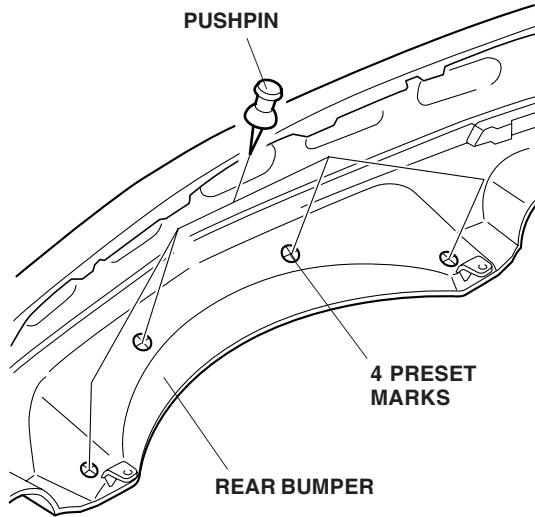

3. While wearing eye protection, drill a hole through each marked location. First drill with a 3 mm drill bit, and finish with a 10 mm drill bit. Remove any burrs from the edges of the holes with a file.

DRILL
(First drill with a 3 mm drill bit, then finish with a 10 mm drill bit.)

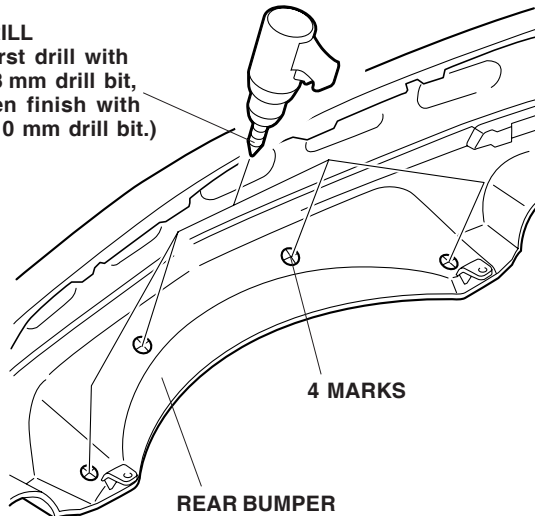

4. Position the rear lower trim over the rear bumper, and secure it with four bolts from inside the rear bumper.

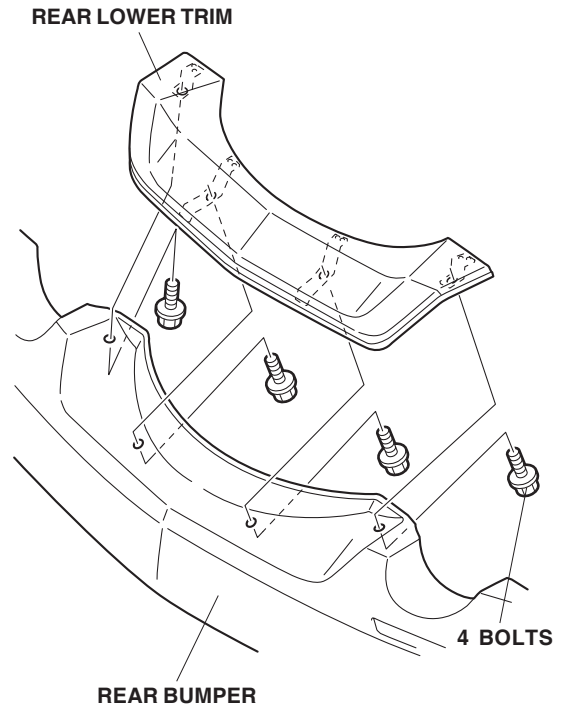

5. Reinstall the rear bumper.