



ACURA INSTALLATION INSTRUCTIONS

Accessory	Application	Publications No.
19" ALUMINUM WHEEL	2008 MDX	BII 37664
		Issue Date AUG 2007

PARTS LIST

Aluminum wheel
(The illustration may differ from the actual wheel.)

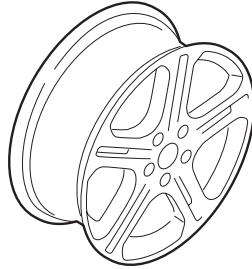

Wheel center cap
(The illustration may differ from the actual center cap.)

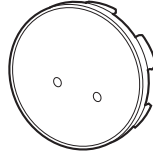

Center cap emblem



2 Push nuts



Tire pressure information label



Important information

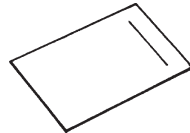

Wheel cleaning information
(Contained in the kit of 08W19-STX-200A only. Give this information to your client.)

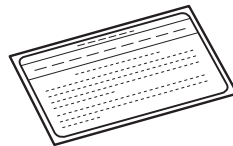

TPMS Information
(Give this information to your client.)

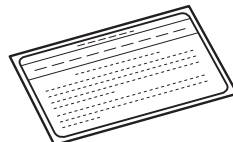

Parts for TPMS sensor assembly

Tire pressure sensor assembly

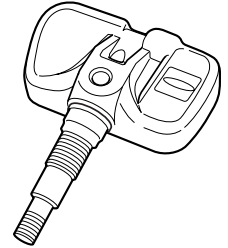

Washer



Valve cap



Valve nut

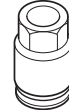

SUPPLIES REQUIRED

- Ratchet wrench
- 11 mm Socket
- Torque wrench
- Isopropyl alcohol
- Shop towel
- HDS

SPECIFICATIONS

Rim size	19 x 8 1/2 J (offset 45)	
Tire size	275/45R19 108Y	
Bolt hole PCD	120.0 (5 holes)	
Tire pressure	Front	35 psi (240 kPa, 2.4 kgf/cm ²)
	Rear	35 psi (240 kPa, 2.4 kgf/cm ²)

INSTALLATION

Client Information: The information in this installation instruction is intended for use only by skilled technicians who have the proper tools, equipment, and training to correctly and safely add equipment to your vehicle. These procedures should not be attempted by “do-it-yourselfers.”

NOTE:

- This aluminum wheel is designed for use on vehicles equipped with TPMS (Tire Pressure Monitoring System).
- This aluminum wheel is equipped with a TPMS sensor. See the Service Manual for tire replacement procedure and the TPMS sensor installation procedure.
- Install the correct size tire.
- Use a tire changer to remove and install the tires. Using a tire lever to remove and install the tires can damage the tire, the wheel, and the TPMS sensor.
- Be careful not to damage the wheel center cap when installing the emblems.
- This center cap emblem kit should be installed only if the ambient air temperature is 60°F (15°C) or above.
- To allow the adhesive to cure, do not wash the vehicle for 24 hours.

1. Clean the mating surface and the valve hole of the aluminum wheel before installing the tire pressure sensor.

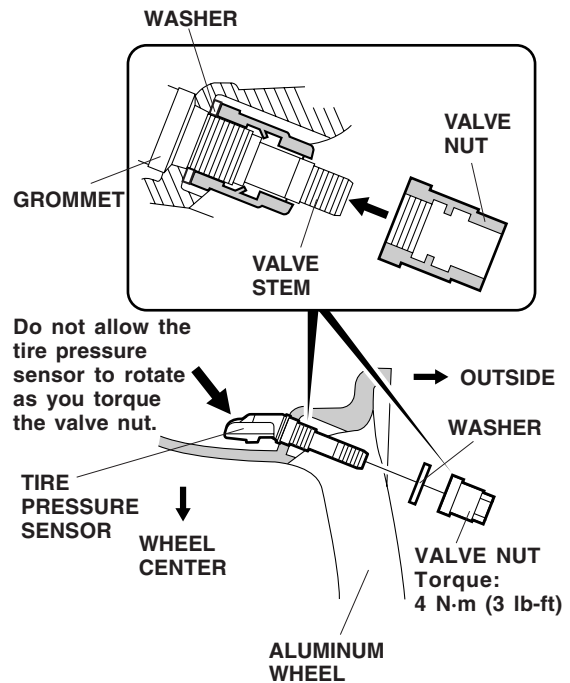

2. Install the tire pressure sensor:

- While holding the tire pressure sensor against the rim, install the valve nut.
- Make sure the tire pressure sensor is resting against the wheel.
- While holding the tire pressure sensor from rotating, torque the valve nut to 4 N·m (3 lb-ft). You may hear a snap or pop as you torque the nut, this is normal.

NOTE:

- Do not reuse the grommet that had been tightened, even one time, to the specified torque; otherwise, the valve stem may leak.
 - Do not use pneumatic or electric tools on the valve nut.
 - Tightening the nut above the specified torque can damage the grommet.
 - Make sure that there is no gap between the sensor and the wheel.
4. Install the tires according to the instructions in the Service Manual. Be careful not to damage the new sensor.

- Using isopropyl alcohol on a shop towel, clean the area where the center cap emblem will attach.

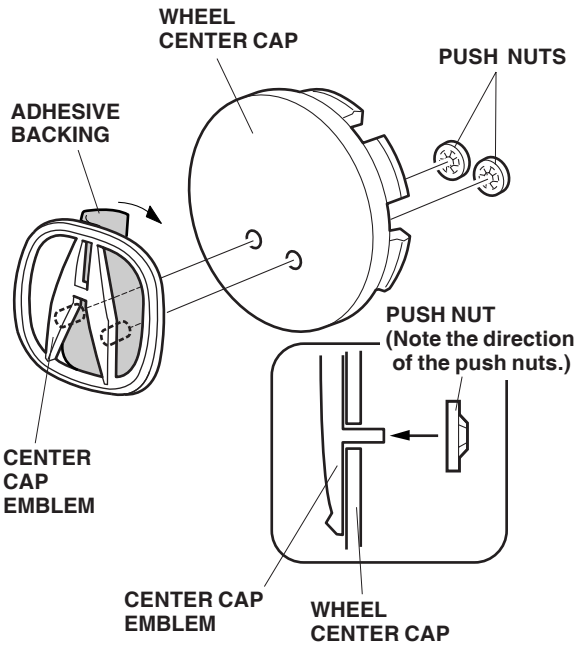

- Remove the adhesive backing from the center cap emblem.
- Attach the center cap emblem to the wheel center cap by aligning its pins with the holes in the wheel center cap. After attaching, press the emblem firmly against the wheel center cap with the palm of your hand for 30 seconds.
- Slide the push nuts onto the pins. Note the direction of the push nuts.

- Open the driver's door. Using isopropyl alcohol on a shop towel, clean the area where the tire pressure information label will attach. Remove the adhesive backing from the label and attach it over the existing tire information label.

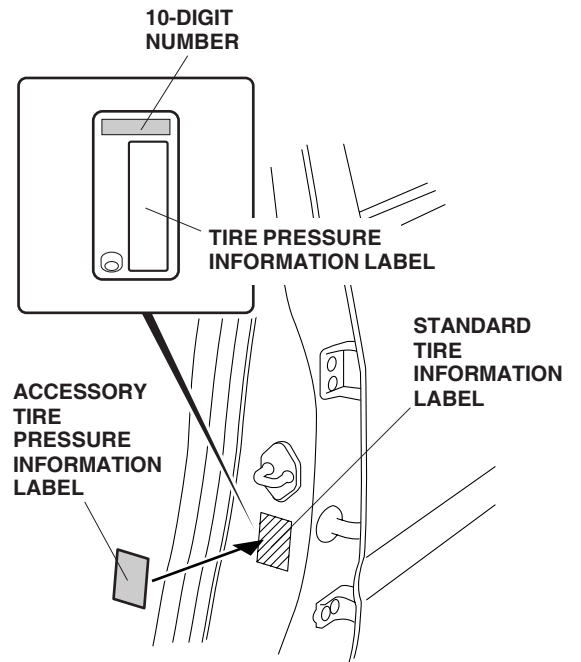

- Install wheels on the vehicle and torque to 127 N·m (95 lb-ft). Put the valve stems at the 12 o'clock position before lowering the vehicle to the ground.
- Memorize the ID tire pressure sensor, as described on the next page.

SENSOR ID LEARNING

NOTE: Before beginning TPMS sensor ID, to ensure the control unit memorizes the correct ID, the vehicle with the new sensor must be at least 3 m (10 ft) from any other TPMS pressure sensor not installed on that vehicle.

12. Connect the HDS to the vehicle, make sure the correct VIN is populated, and enter the mileage.
13. At the System Selection Menu, click TPMS.
14. At the Mode Menu, click DTC and clear any stored codes.
15. Go back to the Mode Menu, click Sensor ID Learning, and follow the screen prompts.

NOTE: If the ID Learning fails, have an assistant drive the vehicle under 10 mph while you start the ID learning process. The TPMS control unit should learn all four sensor IDs. If all four sensors IDs are learned, go to step 17. If one or more of the sensor IDs are not learned, then go to normal troubleshooting in the service manual before continuing.

16. Perform the Inch-up Tire Pressure programming procedure as follows.

LOW AIR PRESSURE WARNING THRESHOLD REPROGRAMMING

17. After performing the sensor ID learning using the HDS, go back to the TPMS Mode Menu, and click on Threshold Rewriting.
18. Select "Reprogramming for accessory tires".
19. Do you want to rewrite the threshold data? Click "YES".
20. "Please enter the tire information code of new tires" will appear. Click the "Key board" icon.
21. Enter the 10-digit tire information code printed on the new tire pressure information label, then click the check icon.
22. Check that the tire pressure is shown on the HDS, and the new tire pressure on the tire information label are the same, click "YES" button for programming.
23. Check that the current air pressure setting shown on the HDS is correct and that "Reprogramming the threshold data for non-standard tires has completed successfully" is shown.
24. After programming, write the tire pressure indicated on the HDS in the service history page for Acura Accessory Wheels, then click the check icon.
25. After programming, sign on the service history page for the Acura Accessory wheels, according to the procedure on step 26.

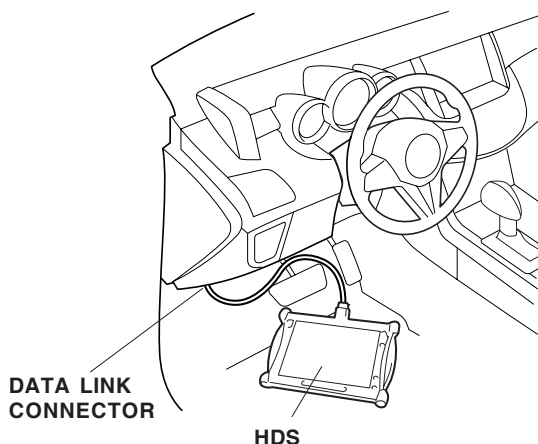

TIRE PRESSURE INFORMATION LABEL

10-DIGIT NUMBER

TIRE AND LOADING INFORMATION			
The combined weight of occupants and cargo should never exceed 525kg or 1158lbs.			
SEATING CAPACITY		TOTAL 7	FRONT 2 SECOND 3 THIRD 2
TIRE	SIZE	COLD TIRE PRESSURE	
FRONT	275/45R19 108V	240KPA, 35PSI	SEE OWNER'S MANUAL FOR ADDITIONAL INFORMATION
REAR		240KPA, 35PSI	
SPARE	T165/80D17 104M	420KPA, 60PSI	
STX2402407			

26. After finishing the work, write the tire size, tire pressure, HDS version, dealer name, technician's signature, and date in the maintenance journal on the Acura Accessory Alloy Wheels page (included in this kit).
27. Attach the Acura Accessory Alloy Wheels page to the vehicle owner's manual. Refer to the "To Dealer" label on the page.

Be sure to explain the contents of "Important Information" to your client before delivering the vehicle

28. Be sure to give the wheel cleaning information and TPMS information to your client.

STANDARD TIRE PRESSURE PROGRAMMING

If the original equipment (standard) tires are to be installed back on the vehicle, the low pressure warning threshold must be changed back. Follow the procedure on page 7.

THRESHOLD DATA CHECK

If for some reason you are unsure of where the low pressure warning threshold is set, it can be checked by using Threshold Data Check. Follow the procedure on page 8.

TPMS Unit Replacement

If the TPMS control is ever replaced and the vehicle has inch-up wheels, the low pressure sensor threshold must be changed. Once the TPMS control is installed, follow steps 12 thru 28.

STANDARD TIRE PRESSURE PROGRAMMING

To return the TPMS programming from the inch-up tire to the standard tire, change the programming in the following procedure:

1. Connect the HDS to the vehicle, make sure the correct VIN is populated, and enter the mileage.
2. At the System Selection Menu, click TPMS.
3. At the Mode Menu, Click the DTC and clear any stored codes.
4. Go back to the Mode Menu, click on Threshold Rewriting.
5. Click on Reprogramming for standard tires and follow the screen prompts.
6. After programming, write the measured tire pressure in the important information, then click the check button.
7. Attach the tire pressure information label for standard tire at the prescribed location.
8. After programming, sign on the maintenance journal in the Acura Accessory Alloy Wheels page, according to the procedures on page 5.

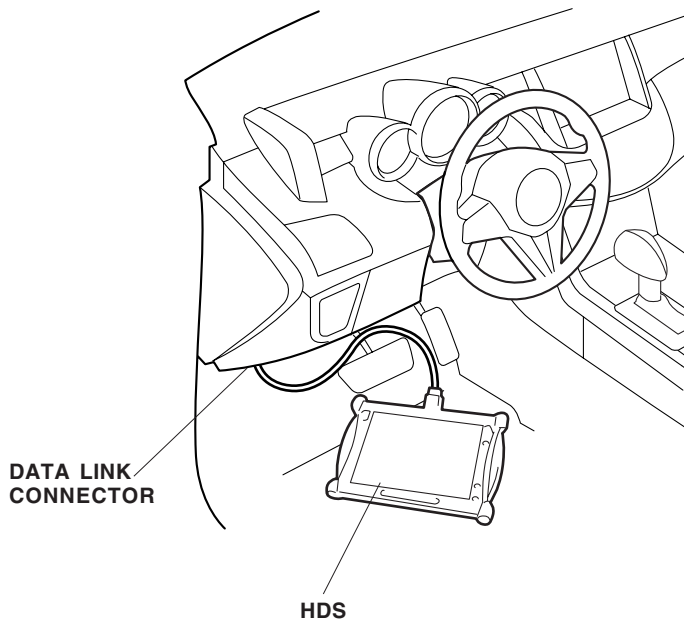

THRESHOLD DATA CHECK

Check the TPMS programming of the pressure on the vehicle:

1. Connect the HDS to the vehicle and make sure the correct VIN is populated and enter the mileage.
2. At the System Selection Menu, click TPMS.
3. Click on Threshold Rewriting.
4. Click on Threshold Data Check.

