

ACURA INSTALLATION INSTRUCTIONS

Accessory	Application	Publications No.
ENGINE BLOCK HEATER P/N 08T44-SNA-100	2007 TL	BII 33321
		Issue Date SEP 2006

PARTS LIST

Engine block heater

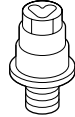

Aluminum washer



Heater harness

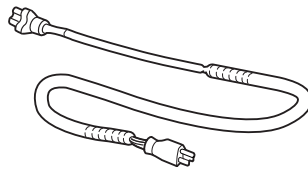

Protective cap

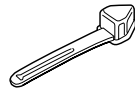

12 Black wire ties
(1 Not used)

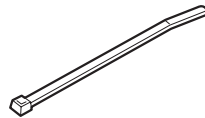

3 Wire ties with clip
(All not used)

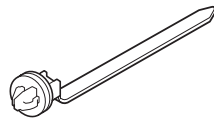

5 White wire ties
(2 Not used)

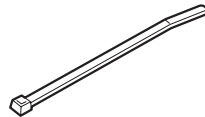

TOOLS AND SUPPLIES REQUIRED

Phillips screwdriver

Ratchet

10 mm, 19 mm and 24 mm Sockets

Torque wrench

Diagonal cutters

Coolant (Honda All Season Antifreeze/Coolant only)

White marker

Tape measure

10 mm Combination wrench

Fender cover

Drain pan

Heavy gloves

NOTE

- Always use Honda All Season Antifreeze/Coolant. Using a non-Honda coolant can result in corrosion, causing the cooling system to malfunction or fail.
- To avoid burning out the element, do not operate the engine block heater before it is installed in the vehicle and before you add coolant.

INSTALLATION

Customer Information: The information in this installation instruction is intended for use only by skilled technicians who have the proper tools, equipment, and training to correctly and safely add equipment to your vehicle. These procedures should not be attempted by “do-it-yourselfers.”

1. Allow the engine and all cooling system components to cool down.
2. Place a clean drain pan under the radiator drain plug, then loosen the drain plug from the bottom of the radiator to drain the coolant. Remove the radiator cap to increase the flow.

NOTE: Radiator coolant will damage paint. Quickly rinse any spilled coolant from painted surfaces.

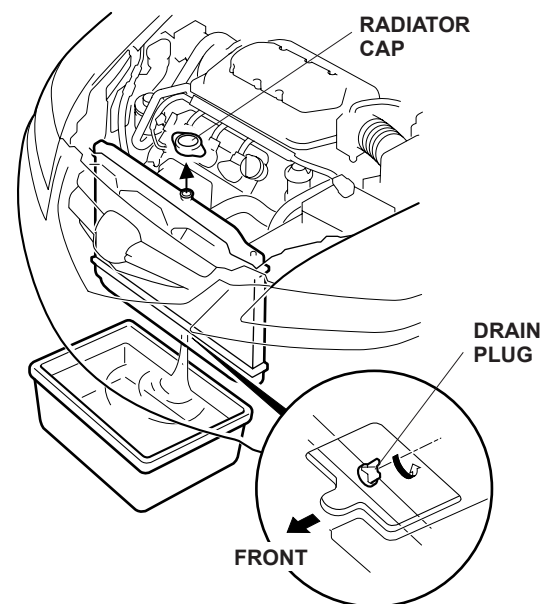

- Remove the battery cover (two pins and one hook).

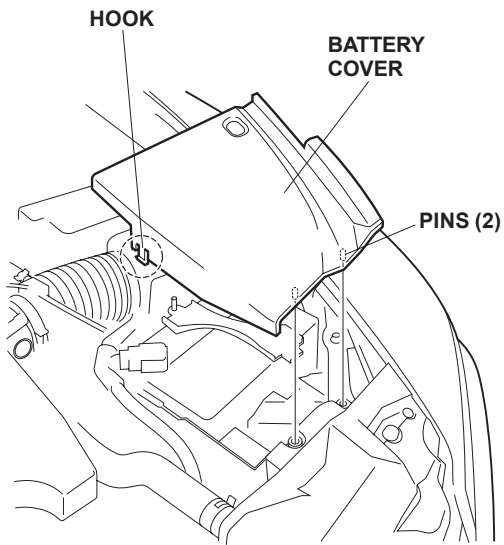

- Make sure you have the anti-theft code for the radio, then write down the frequencies for the preset buttons. Disconnect the negative cable from the battery.
- Open the positive cable cover, and disconnect the positive cable. Loosen the two nuts, and remove the battery setting plate. Remove the battery and the case.

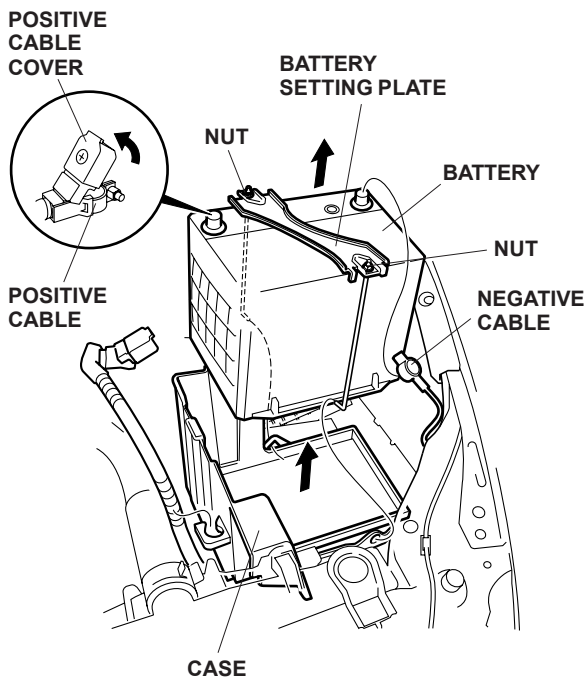

- Remove the right side cover (three pins and three hooks).

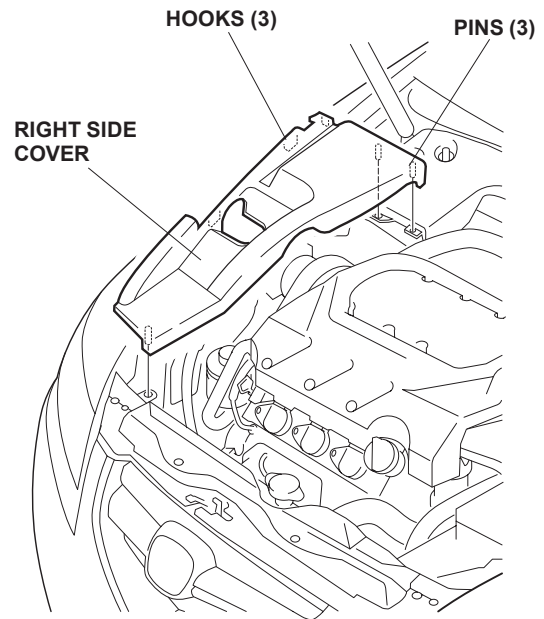

- Remove the radiator cover (five clips and two pins).

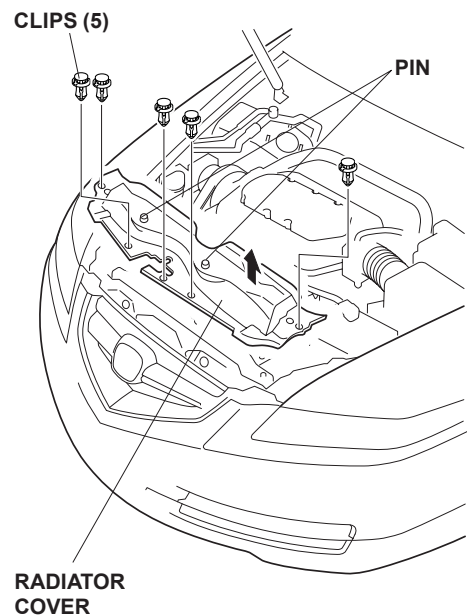

- Remove the air duct cover (two clips), and remove the air duct.

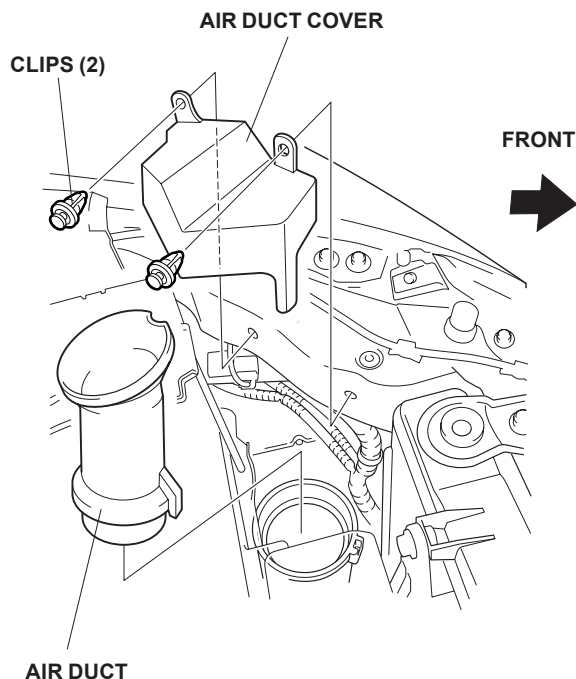

- Remove the coolant reservoir and coolant reservoir bracket (one bolt).

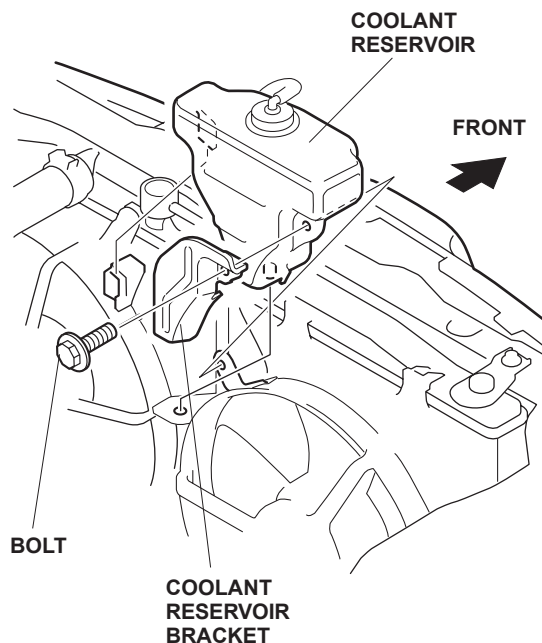

- Using a 19 mm socket, remove the drain bolt and washer from left side of the engine block. The coolant remaining in the engine block will flow out of the bolt hole when the drain bolt is removed. Retain the bolt, it will be used if the engine block heater is removed.

NOTE: Use a new washer if the drain bolt is reinstalled.

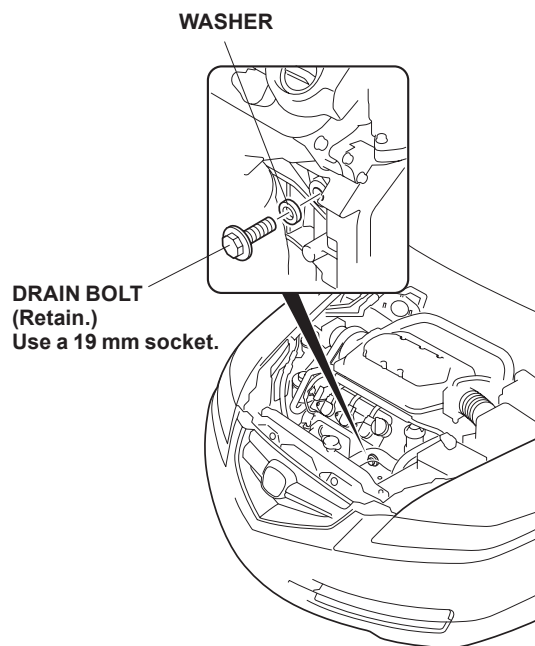

- Install the engine block heater with the aluminum washer into the hole using a 24 mm socket. Torque the engine block heater to 60 N·m (44 lb·ft).

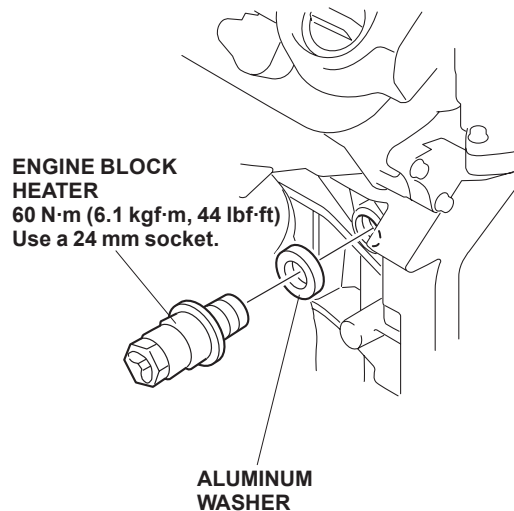

12. Using a tape measure and white marker, measure and mark the heater harness at the measurement points.

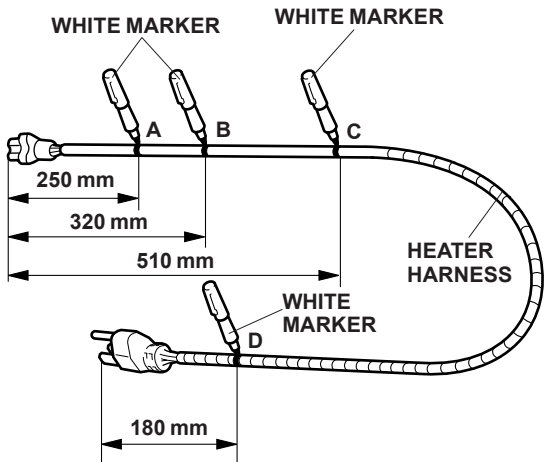

13. Plug the heater harness connector into the engine block heater.

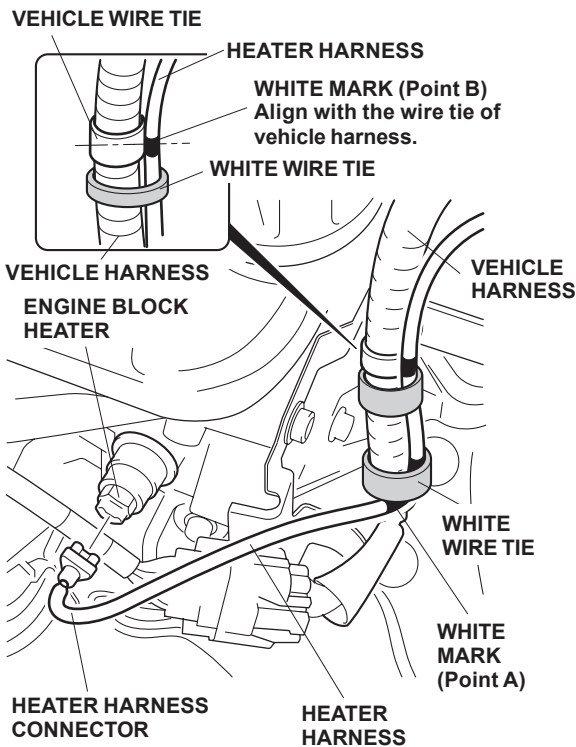

14. Align the white mark (point B) on the heater harness with the vehicle wire tie, and secure the heater harness to the vehicle harness with two white wire ties as shown.

15. Route the heater harness as shown. Align the white mark (point C) on the heater harness with the end of the fan frame, and secure the heater harness to the fan frame with one white wire tie over the white mark.

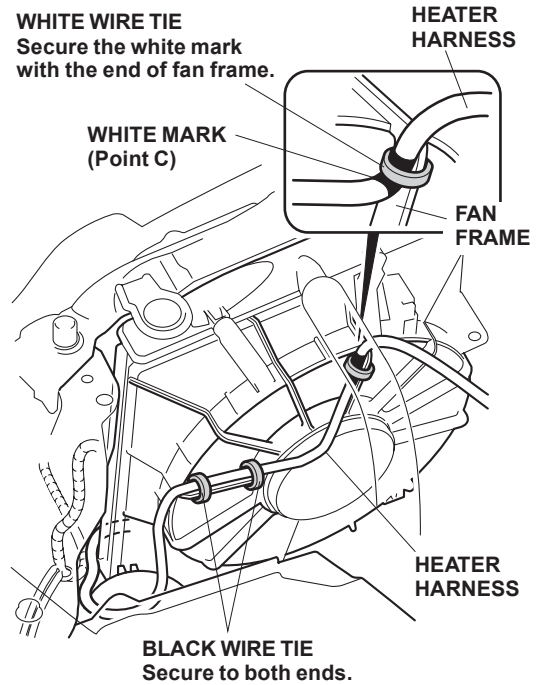

16. Secure the heater harness to both ends of the fan frame with two black wire ties
17. Route the heater harness along the vehicle harness through the bulkhead to the left side.

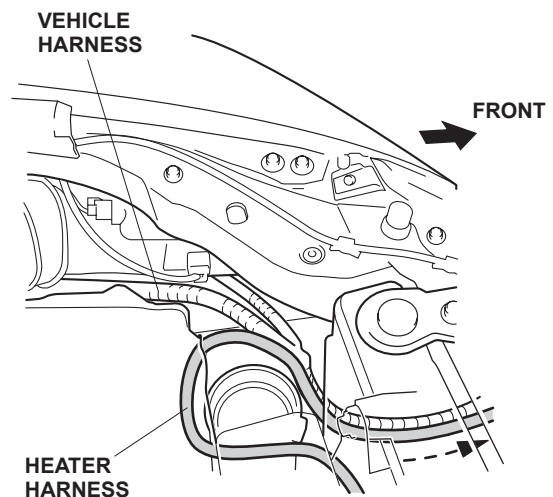

18. Route the heater harness along the vehicle harness.

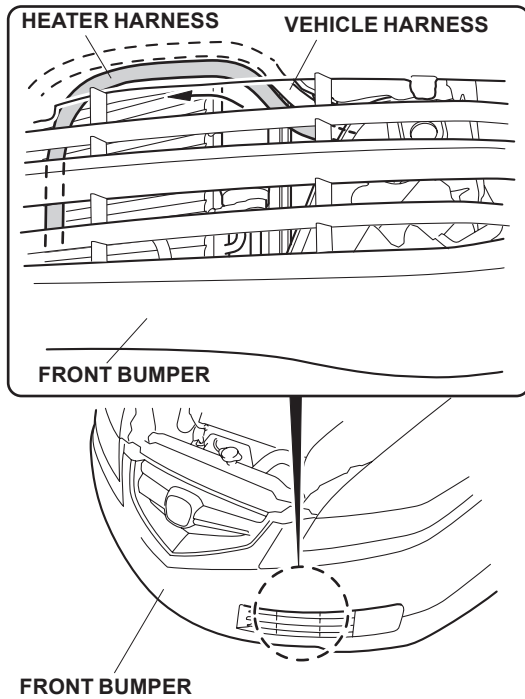

- **TYPE-S:** Go to step 21.
- **TYPE-S with FRONT UNDER SPOILER:** Go to step 24.

19. Route the heater harness to the bumper grille opening, secure it to the bumper grille with two black wire ties as shown.

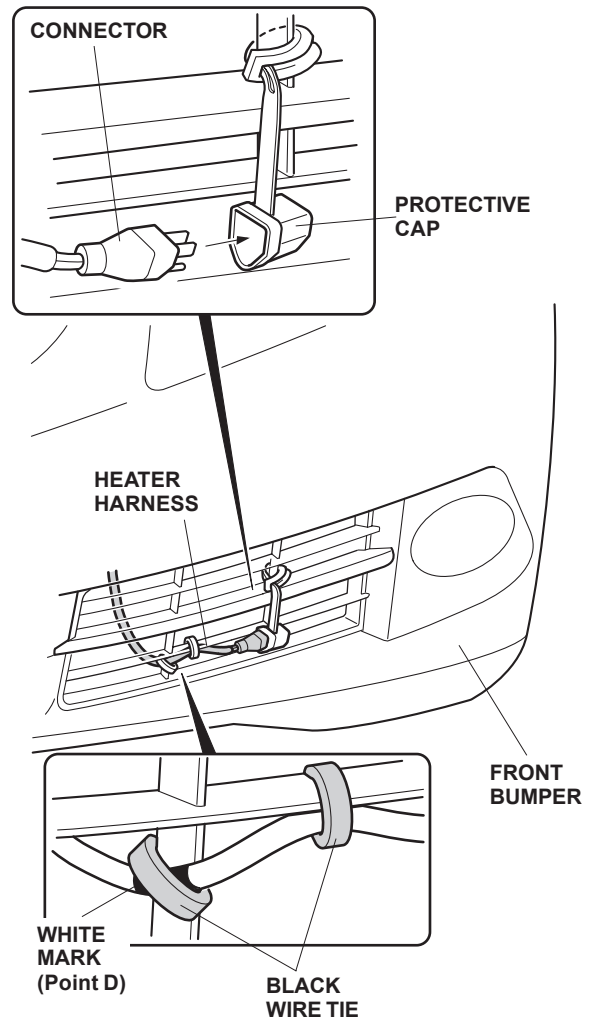

20. Attach the protective cap to the bumper grille, and plug the heater harness connector into the protective cap. Go to step 26.

TYPE-S

21. Cut off a piece of the bumper grille in the area shown.

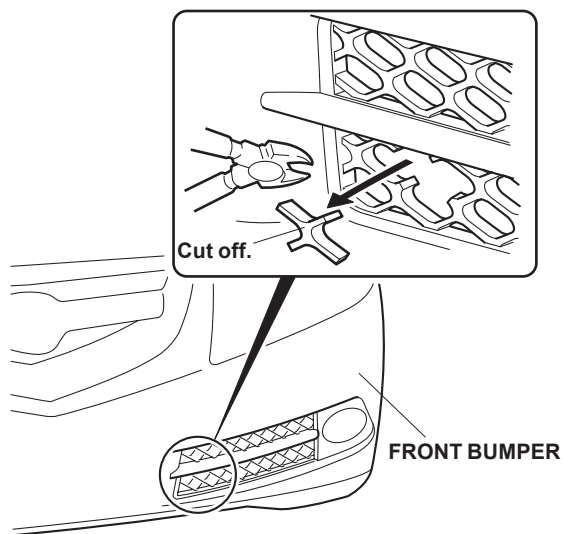

22. Route the heater harness to the bumper grille opening, and secure it to the bumper grille with two black wire ties as shown.

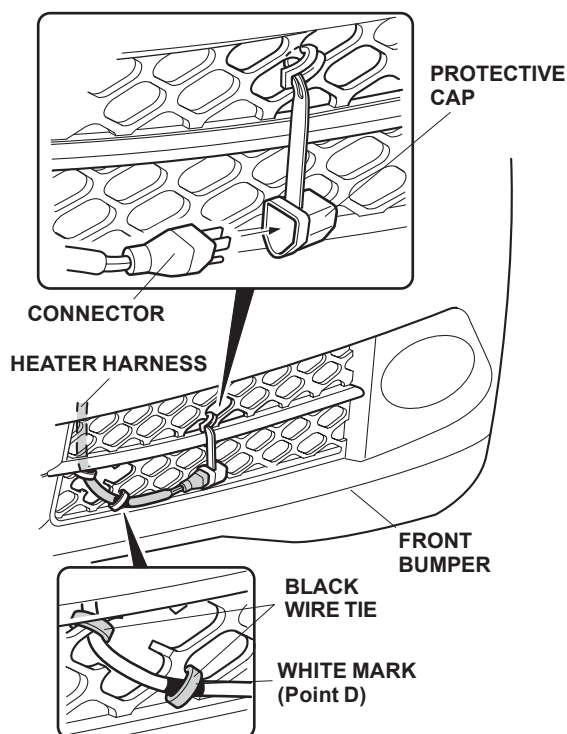

23. Attach the protective cap to the bumper grille, and plug the heater harness connector into the protective cap. Go to step 26.

TYPE-S with FRONT UNDER SPOILER

24. Secure the heater harness to the bumper grille with one black wire tie as shown.

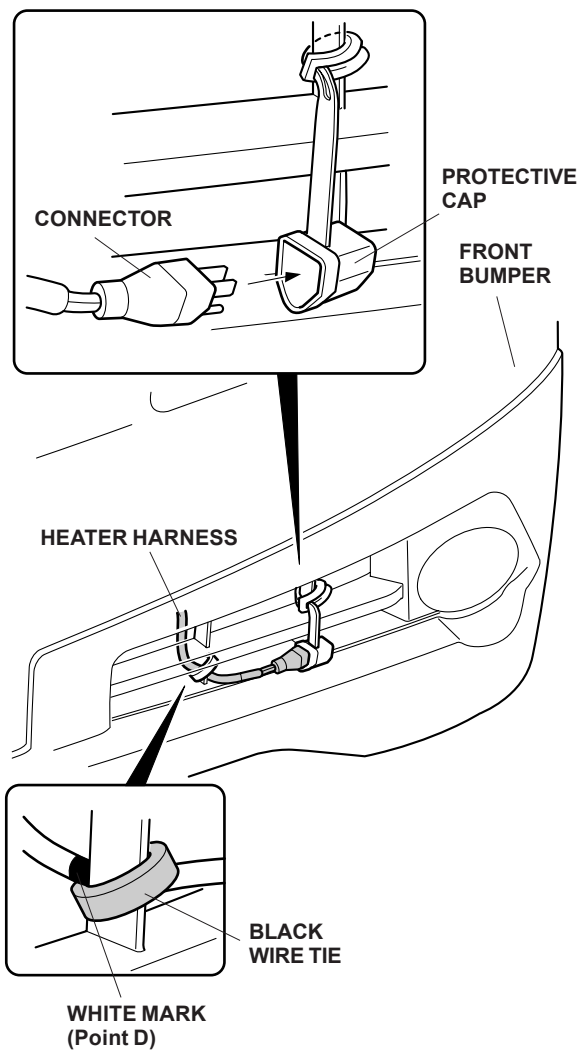

25. Attach the protective cap to the bumper grille, and plug the heater harness connector into the protective cap.

- Secure the heater harness to the vehicle harness with two black wire ties.

NOTE: Take care not to interfere the heater harness with the receiver tank.

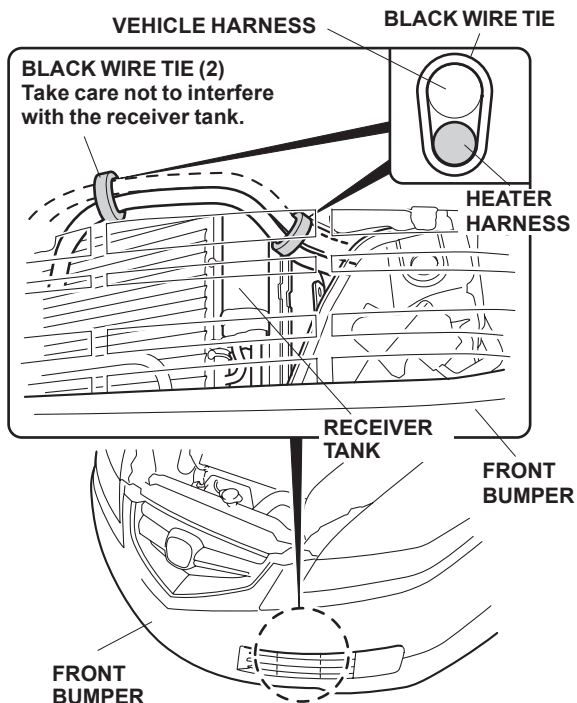

- Secure the heater harness to the vehicle harness with two black wire ties.

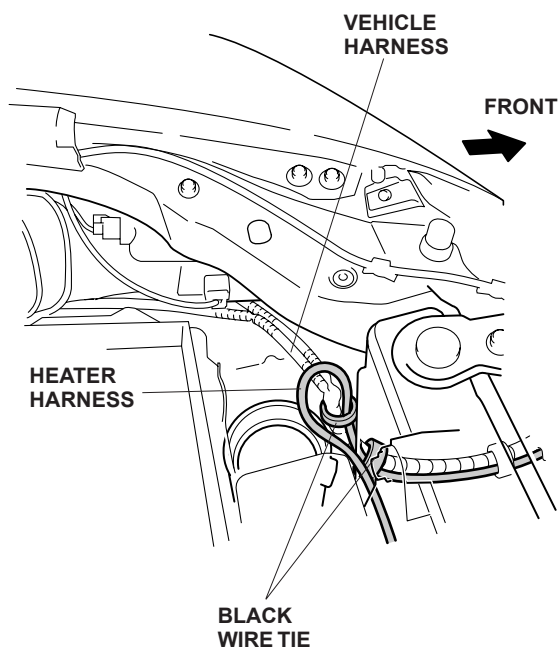

- Secure the heater harness to the vehicle harness with three black wire ties as shown.

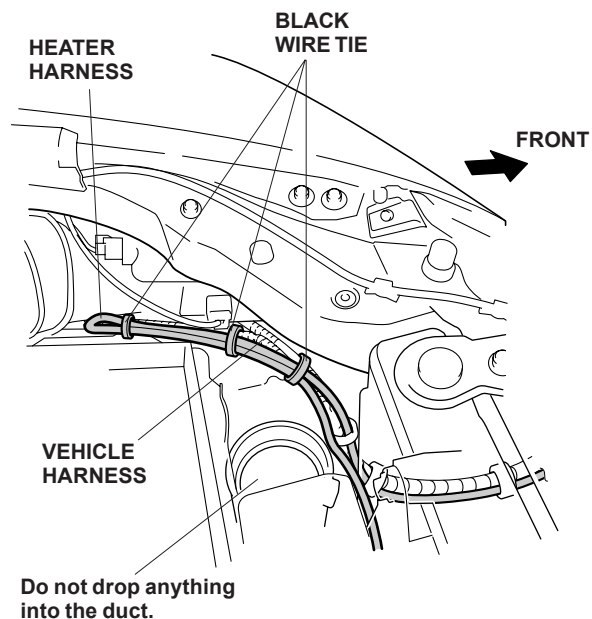

- Reinstall all removed parts except for the battery and battery cover. Check that all clips and fasteners are installed securely.
- Check that the radiator drain plug is installed securely.
- Fill the system with the recommended coolant. Follow the instructions described in the service manual to fill and bleed the cooling system.
- Check the coolant reservoir for correct level and check the cooling system for signs of leakage. Repair as necessary.
- Check that the heater harness is routed properly and all connectors are plugged in.
- Put the drain plug (removed in step 10) in the glove box.
- Reinstall the battery and reconnect the positive and negative cable to the battery. Reinstall the battery cover.
- Enter the customer's radio anti-theft code, and reset the radio station presets.
- Reset the clock.