



ACURA INSTALLATION INSTRUCTIONS

Accessory

**RUNNING BOARD
P/N 08L33-STX-200A**

Application

2007 MDX

Publications No.

BII 32734

Issue Date

OCT 2006

PARTS LIST

Right running board

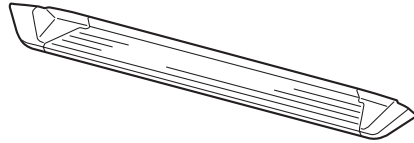

Left running board

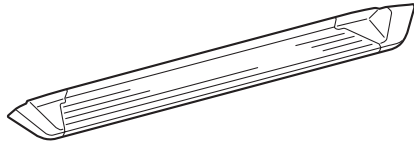

2 Brackets A

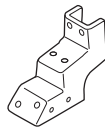

4 Brackets B

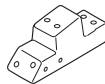

6 Brackets C

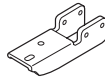

24 Long flange bolts



24 Short flange bolts



36 Flange nuts



TOOLS AND SUPPLIES REQUIRED

Ratchet

10 mm and 13 mm Sockets

10 mm and 13 mm Combination wrenches

Blanket

Torque wrench

INSTALLATION

Customer Information: The information in this instruction is intended for use only by skilled technicians who have the proper tools, equipment, and training to correctly and safely add equipment to your vehicle. These procedures should not be attempted by "do-it-yourselfers."

NOTE:

- Thoroughly clean the bottom of the body between the front and rear wheels.
- Be careful not to damage the body paint finish. To prevent damage, place a blanket under the running board during the installation.
- These instructions show the left side running board being installed; the same procedure applies to installing the right running board.

1. On the left side of the vehicle, install the one Bracket A and two Brackets B along the body using 12 long flange bolts. Thread the long flange bolts in about three or four turns.

NOTE: If the undercoat puts on the body surface, remove the undercoat from the body surface using a scraper or equivalent tool before installing the bracket A. Take care not to damage the painted surface of the body. If necessary, clean the threads using a tap.

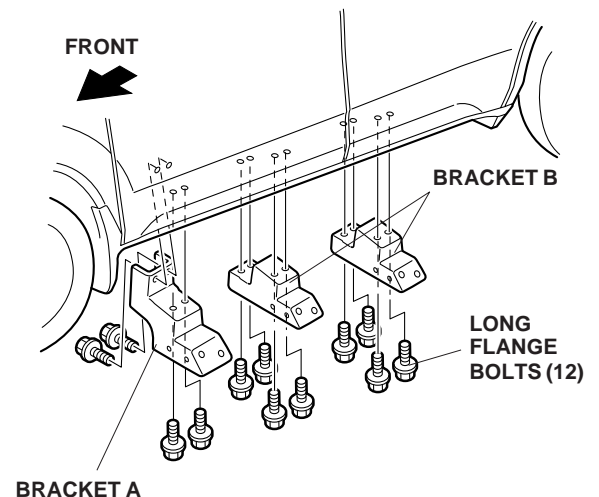

- Remove the two pieces of paper holding the bolts from the rear of the left running board.

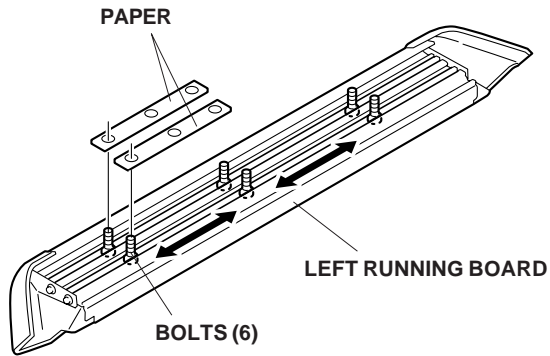

- Install the three Brackets C on the left running board with the bolts through the holes in the brackets. Install the six flange nuts on the bolts.

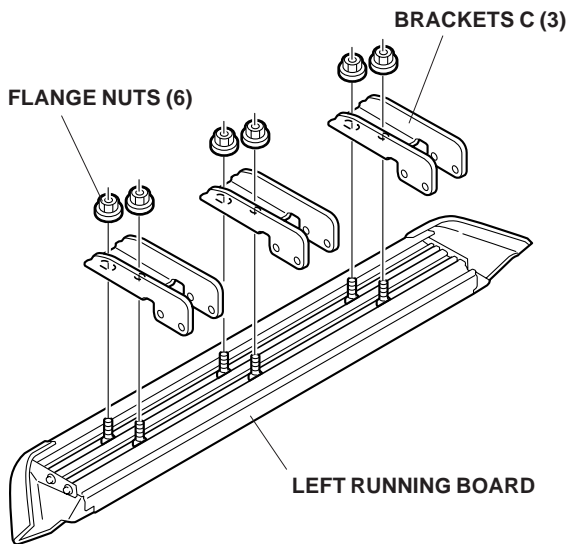

- Loosely install the Brackets C on the left running board to the Bracket A and Brackets B on the body with the 12 short flange bolts and the 12 flange nuts.

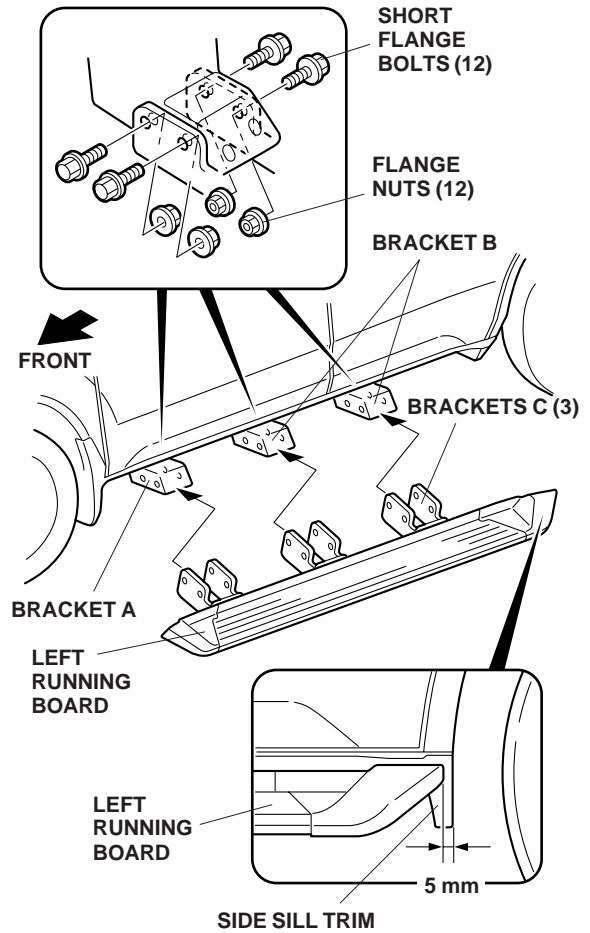

- Align the rear of the left running board with the side sill trim as shown, then tighten the 12 short flange bolts. Torque the short flange bolts to 27 N·m (20 lb-ft).
- Torque the 12 long flange bolts you installed in step 1 to 27 N·m (20 lb-ft).
- Repeat steps 1 through 6 to install the running board on the right side of the vehicle.