

<h1>INSTALLATION INSTRUCTIONS</h1>	Accessory	Application	Publications No.
	ROOF RACK P/N 08L02-S3V-201	2006 MDX	BII 30977
			Issue Date SEP 2005

## PARTS LIST

Front roof rack

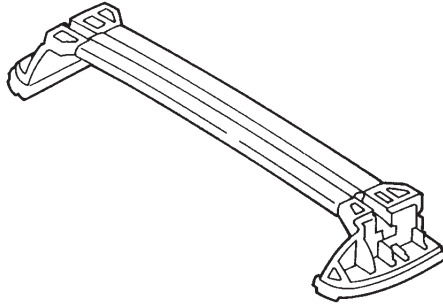

Rear roof rack

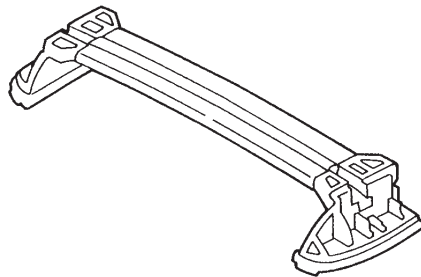

2 Left covers

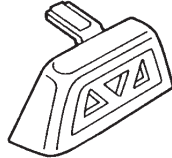

2 Right covers

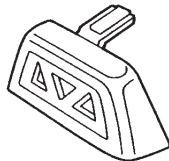

8 Torx nuts



## TOOLS AND SUPPLIES REQUIRED

- Flat-tip screwdriver
- Shop towel
- Long-nose pliers
- T-30 Torx driver
- Hacksaw (32 tpi blade)

## INSTALLATION

### NOTE:

- Be careful not to damage the roof or other finished body surfaces when installing the roof rack.
  - Do not interchange the front and rear parts, or the right and left parts.
  - Refer to the vehicle owner's manual for loading limits and procedures.
1. Place a shop towel under a flat-tip screwdriver and pry up on the rear end of each roof molding.

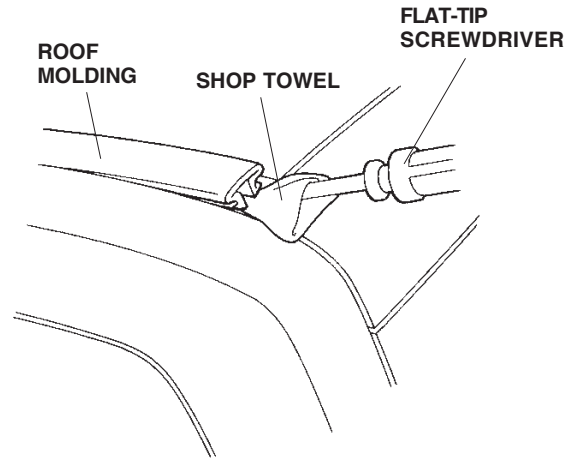

2. Remove the roof moldings by carefully pulling them upward.

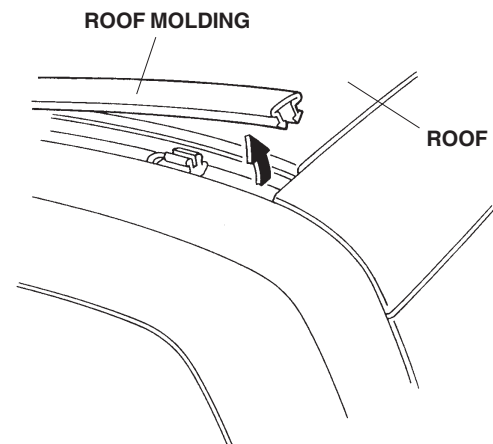

- If a clip is attached to the roof molding after removing the roof molding, remove the clip and reposition it on the roof.

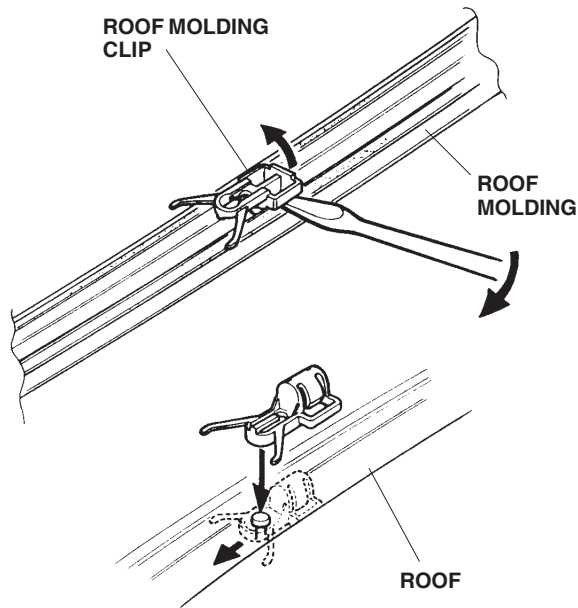

- Remove the four retaining clips (two on each side) from the stud bolts using long-nose pliers.

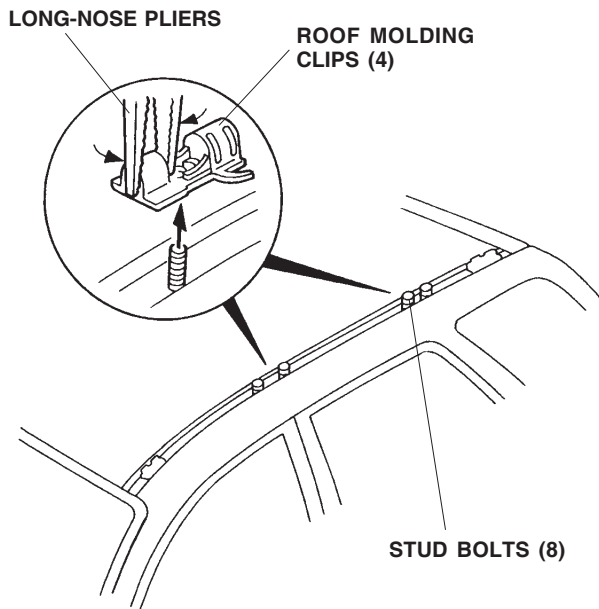

- Using a hacksaw, cut each roof molding according to the dimensions shown. Reinstall the moldings into the roof channels.

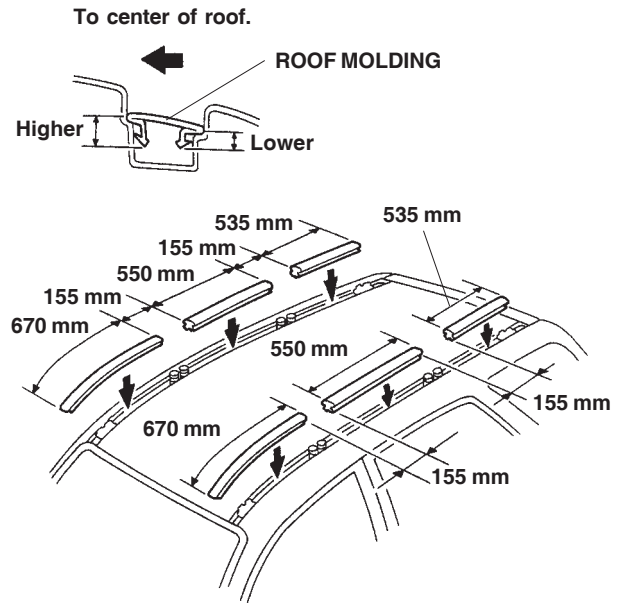

- Position the front and rear roof racks on the roof by aligning the holes with the studs of the roof, and install the Torx nuts through the holes onto the studs. Using a T-30 Torx driver, torque the nuts to 7 to 10 N•m (5 to 8 lb-ft).

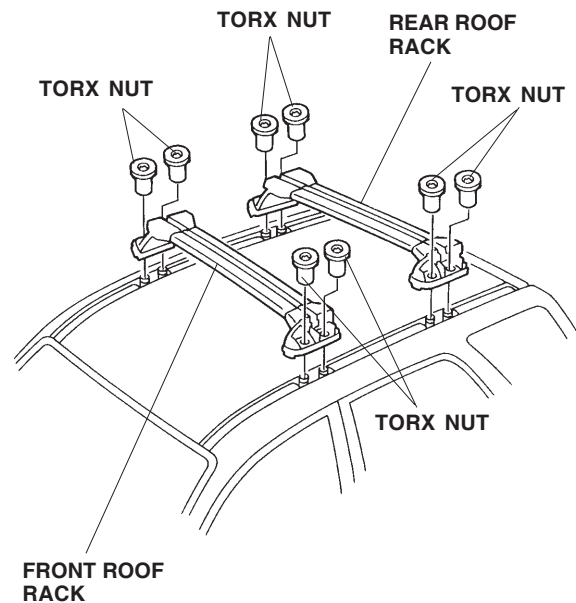

7. Align the tab on the roof rack cover with the groove in the roof rack, and install the roof rack covers.

