



INSTALLATION INSTRUCTIONS

Accessory

CARGO NET
P/N 08L96-S3V-201

Application

2006 MDX

Publications No.

BII 30958

Issue Date

SEP 2005

Put this information in the glove box with the vehicles owner's manual.

PARTS LIST

Cargo net

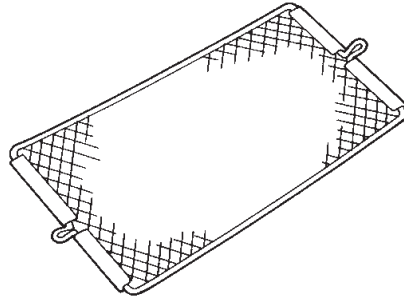

4 Hooks



TOOLS REQUIRED

Small flat-tip screwdriver

INSTALLATION

NOTE:

- Some luggage stored in the cargo net may interfere with the tailgate when it is closed. To prevent damage to the cargo net, do not store large or fragile articles in the cargo net.
 - Before storing articles that have sharp edges or corners, wrap them in paper or a blanket so their sharp edges or corners will not contact the cargo net directly.
1. Using a small flat-tip screwdriver or the ignition key, release the seat belt lower hook from each third row seat, then attach the seat belt clip to the seat belt.

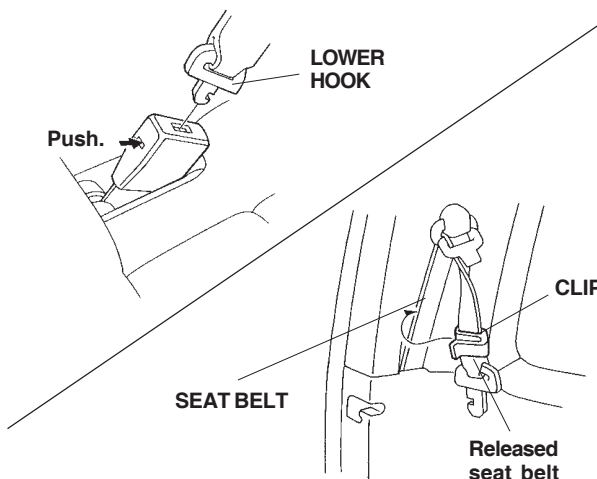

2. Remove the headrests by pushing the release buttons and pulling the headrests out.

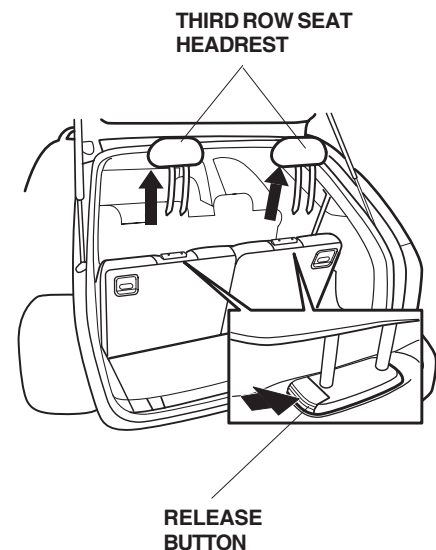

3. Store the headrests in the storage compartment under the cargo floor. Insert the shafts of the headrests into the holes in the sides of the storage compartment.

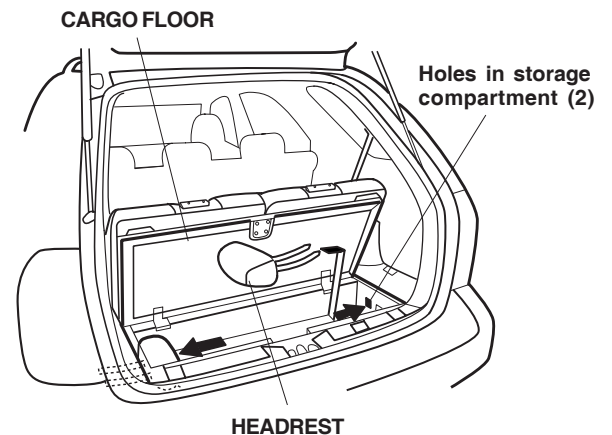

4. Fold down both third row seats.

Installing the Cargo Net in the Horizontal Position

5. Attach the four hooks onto the cargo net in the areas shown.

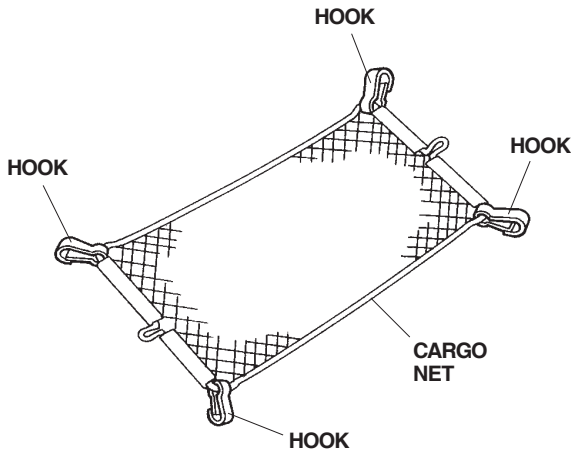

6. Attach the hooks to the anchors in the cargo area.

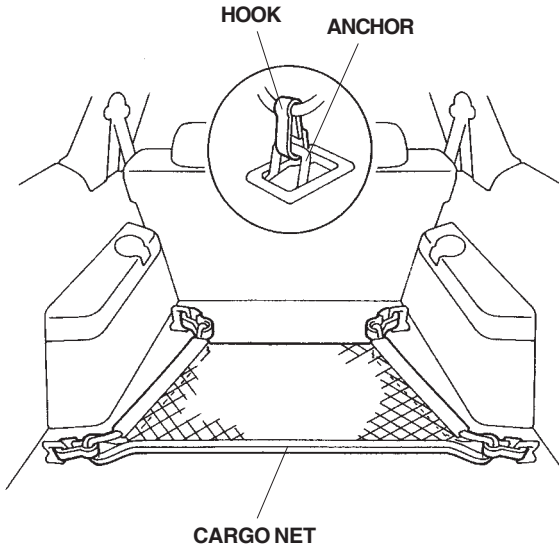

Installing the Cargo Net in the Vertical Position

7. Attach two hooks to the cargo net in the areas shown.

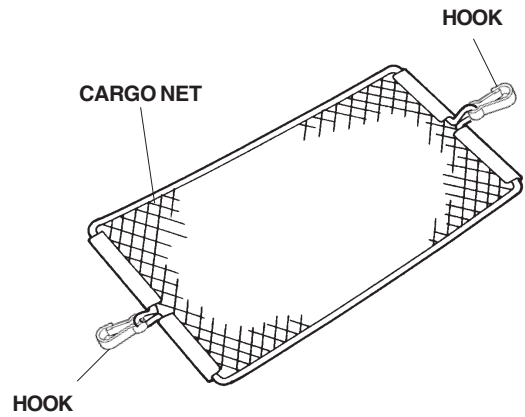

8. Fold the cargo net in half, attach the hooks to the anchors in the floor, and attach the loops to the hooks on the side panel.

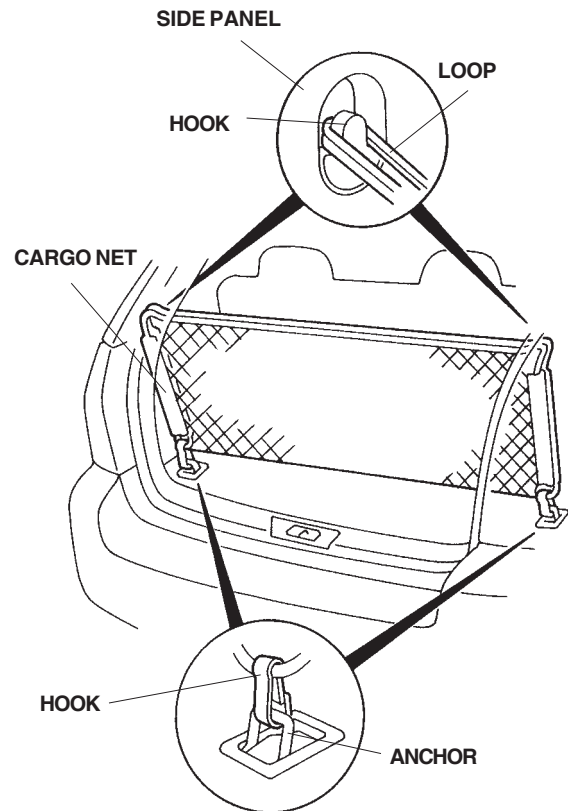

9. Put these instructions and the remaining two hooks (if necessary) in the glove box for your customer.