



ACURA INSTALLATION INSTRUCTIONS

Accessory	Application	Publications No.
REAR UNDER SPOILER	2005 TSX	BII 28368
		Issue Date
		OCT 2004

PARTS LIST

Rear under spoiler

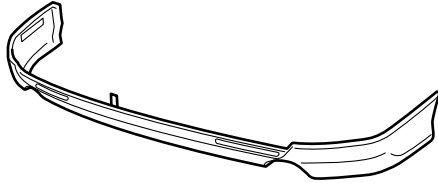

2 Short step bolts

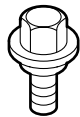

4 Medium-length step bolts

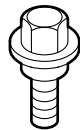

4 Long step bolts

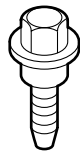

4 Self-tapping screws



6 Clip nuts



4 Spring nuts



2 Exhaust pipe finishers

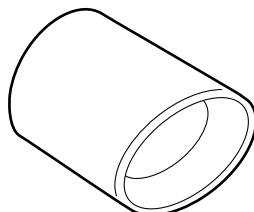

TOOLS AND SUPPLIES REQUIRED

Phillips screwdriver
Clip remover
Ratchet
10 mm socket
Isopropyl alcohol
Shop towel
Masking tape
10 mm wrench
Torx wrench
Diagonal cutters
Pushpin

INSTALLATION

NOTE:

- The rear under spoiler cannot be used with optional splash guards.
- Be careful not to damage the rear bumper and body paint finish.
- This rear under spoiler kit should only be installed if the ambient air temperature is 60°F (15°C) or above.
- To allow the adhesive to cure, do not wash the car for 24 hours.
- The exhaust pipe is hot just after stopping the engine. Install this kit when the exhaust pipe is cool.

1. Remove the two clips and two Torx bolts from the bottom of the rear bumper.

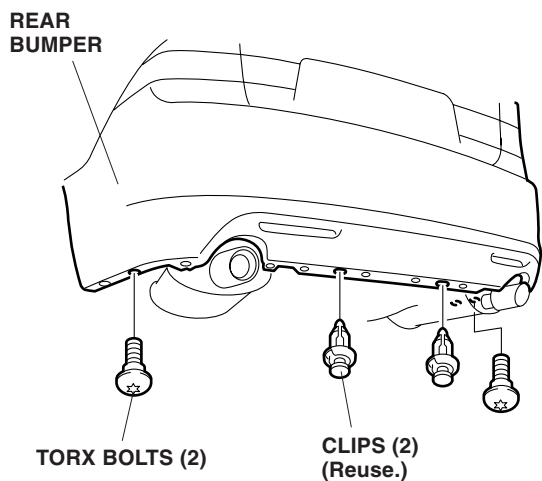

2. Install six clip nuts onto the bottom edge of the rear bumper; make sure the threaded side of the clip is face up and the holes in the clips align with the holes in the bumper. Install four spring nuts over the dimpled areas on the right and left ends of the bumper.

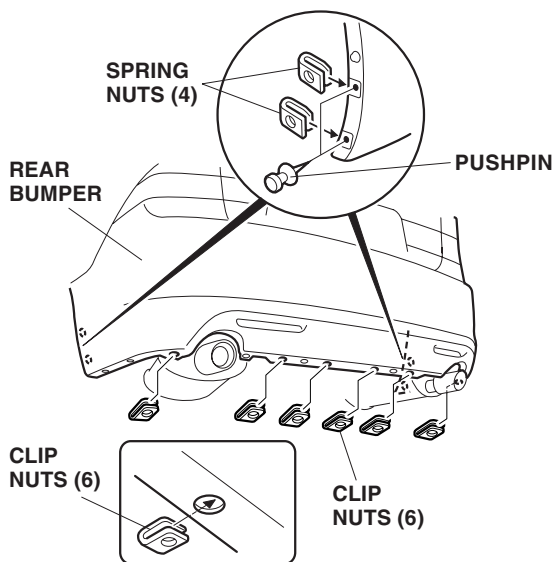

3. Using the pushpin, pierce a hole through the dimpled areas in the rear bumper.
4. Reinstall the two clips removed in step 1.

5. Cut off the mold flashing from the rear under spoiler.

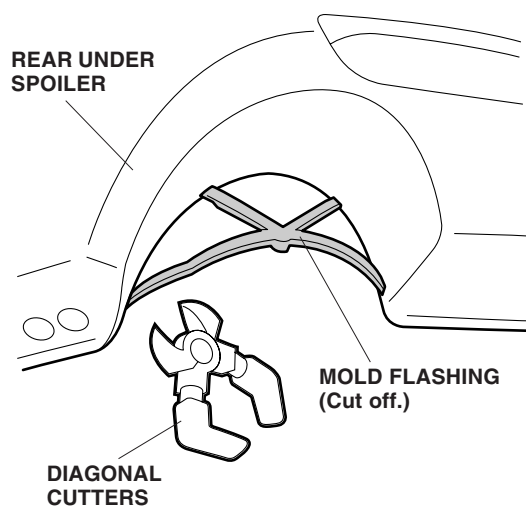

6. Attach a strip of masking tape to the end of adhesive backing of the rear under spoiler, peel back the adhesive backing, and temporarily attach the adhesive backing to the top surface of the rear under spoiler. Do not remove the adhesive backing with tab yet.

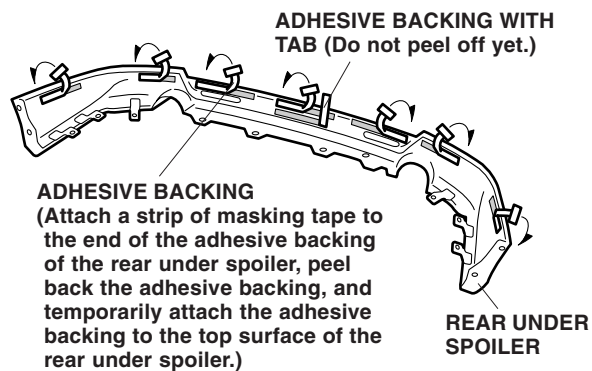

- Using isopropyl alcohol on a shop towel, clean the areas of rear bumper where the double-sided adhesive tape of the rear under spoiler will attach.
- Align the rear under spoiler with the rear bumper and install it with the two short step bolts, four medium-length step bolts, four long step bolts, and four self-tapping screws.

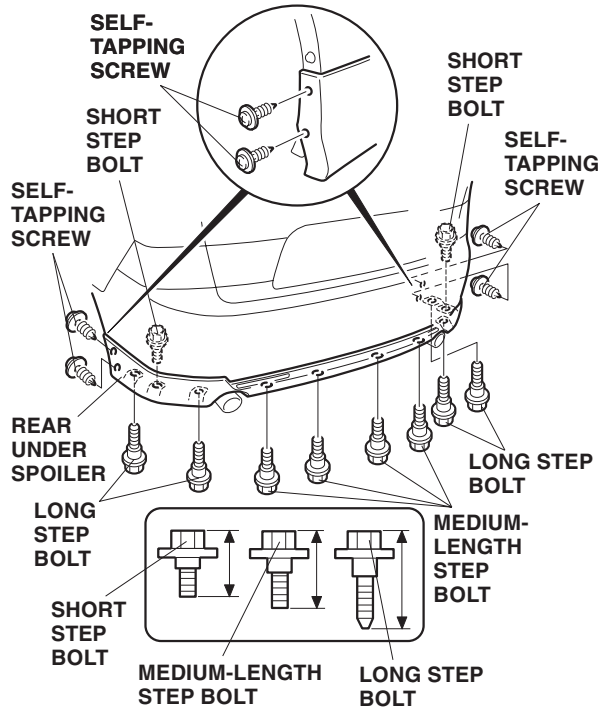

- Press the rear under spoiler against the rear bumper, then remove the remaining adhesive backings, then remove the remaining adhesive backings. After removing the adhesive backings, apply pressure against the rear under spoiler for 30 seconds.

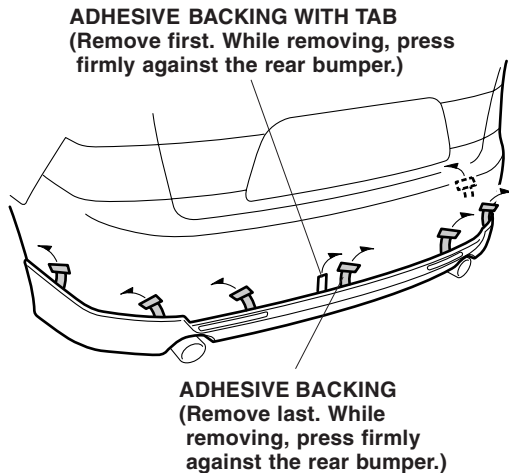

- Remove the vehicle's exhaust pipe finisher, and retain the flange bolt.

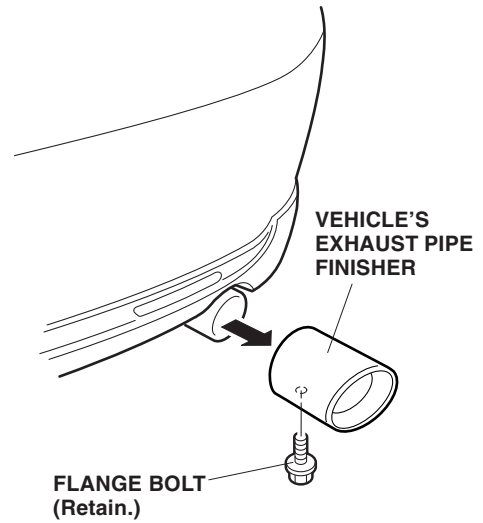

- Install the exhaust pipe finisher from the kit onto the exhaust pipe, with the flange bolt. Be sure to position the bolt facing down.

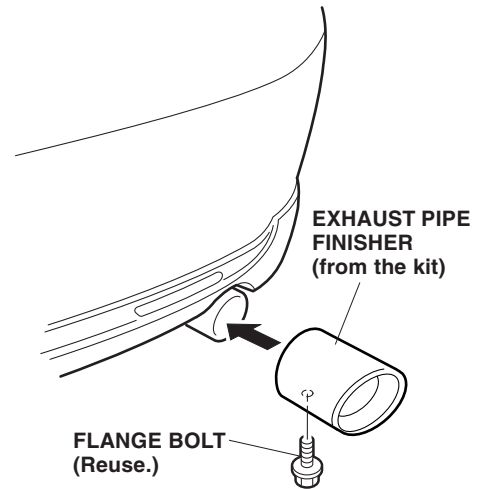

12. Firmly press the exhaust pipe finisher onto the exhaust pipe until it bottoms on the end of exhaust pipe. Secure the exhaust pipe finisher with the flange bolt.
- Tighten the flange bolt while holding the exhaust pipe finisher with your hand.
 - Torque the flange bolt to 9.8 N·m (7.2 lb-ft). Do not over tighten.

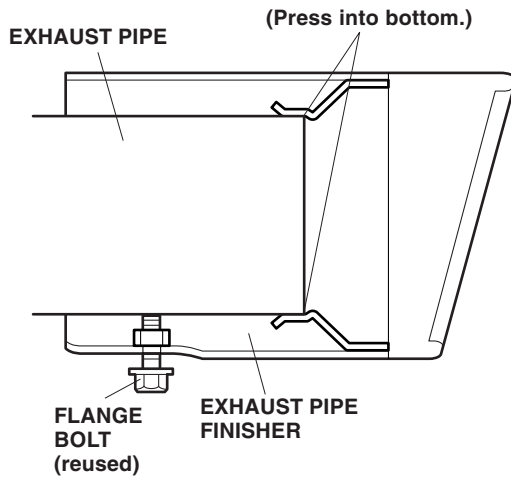

INSPECTION AFTER INSTALLATION

- Start the engine, and rev it up a few times. Listen for any rattling noise coming from the exhaust pipe finisher, and adjust if necessary.
- Do not clean or polish the exhaust pipe finisher with waxes containing abrasive compounds as they may damage the surface.