

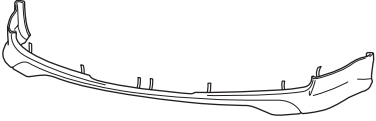
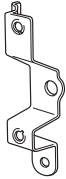
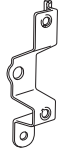

PARTS LIST

- Front under spoiler 

- Left bracket (Marked L) 

- Right bracket (Marked R) 

- 3 Self-tapping screws 

- 6 Screws 

- 4 Short clips 

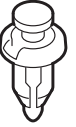
- 2 Long clips 

- 5 Spring nuts 

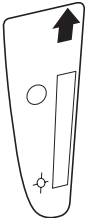
- Template A 

Template B

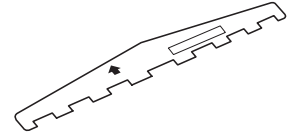

Left cover (Marked L)

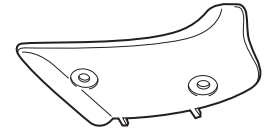

Right cover (Marked R)

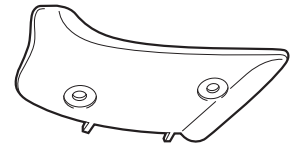

TOOLS AND SUPPLIES REQUIRED

- Phillips screwdriver
- Flat-tip screwdriver
- 10 mm Wrench
- Center punch
- Drill
- 3 mm, 6 mm, and 10 mm Drill bits
- Felt-tip pen
- File
- Isopropyl alcohol
- Shop towel
- Eye protection (face shield, safety goggles, etc.)

INSTALLATION

Customer Information: The information in this installation instruction is intended for use only by skilled technicians who have the proper tools, equipment, and training to correctly and safely add equipment to your vehicle. These procedures should not be attempted by “do-it-yourselfers.”

NOTE:

- Be careful not to damage the body paint finish.
- This front under spoiler kit should only be installed if the ambient air temperature is above 60°F (15°C).

1. With the vehicle on a lift, remove two bolts and two clips from the lower side of the front bumper.

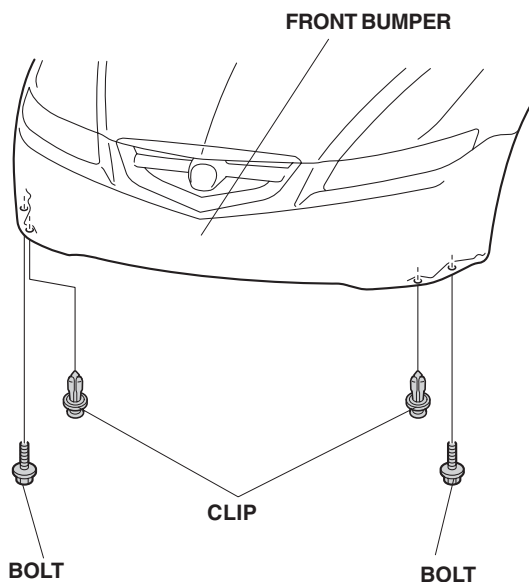

2. Tape template B to the bottom of the front bumper, and mark the bumper using a felt-tip pen.

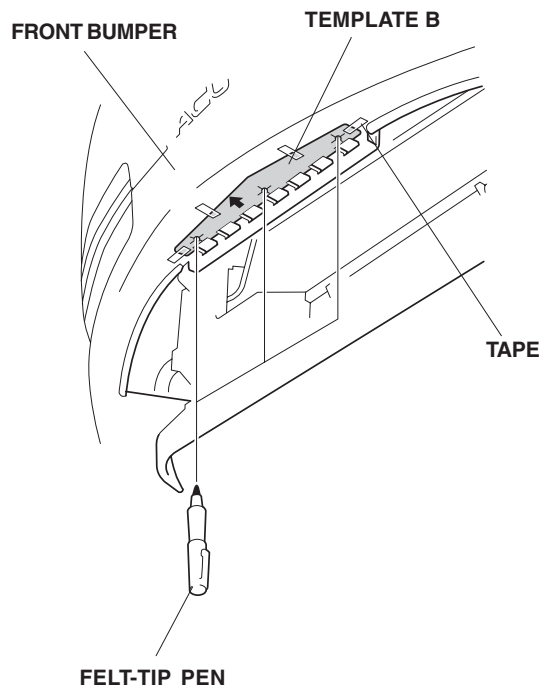

3. Remove the template and center punch the marks you made.

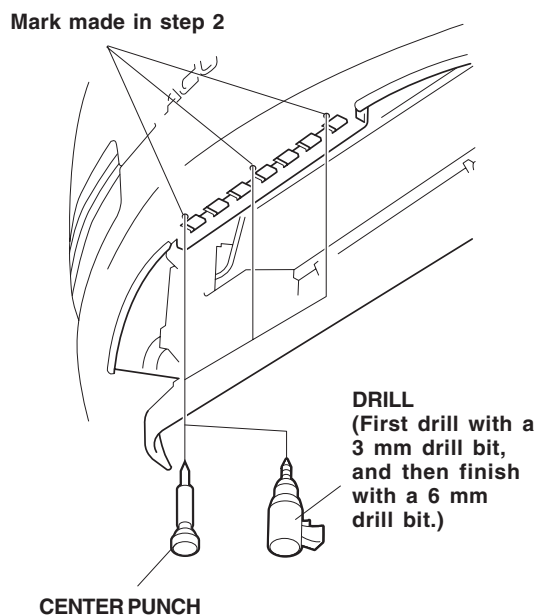

4. While wearing eye protection, drill a 6 mm hole through each marked location. First drill with a 3 mm drill bit, and then finish with a 6 mm drill bit. Remove all burrs from the edges of the holes with a file.

5. Install three spring nuts into the three drilled holes in the bottom of the bumper.

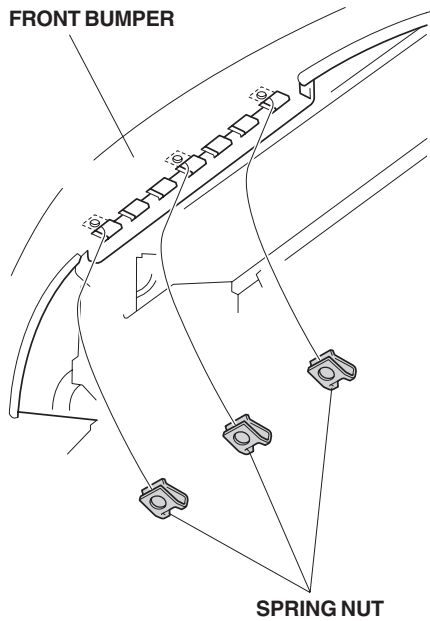

6. Position the left cover on the front bumper and align the end of the cover with the edge of the bumper. Mark the center of each circle through the left cover with a felt-tip pen.

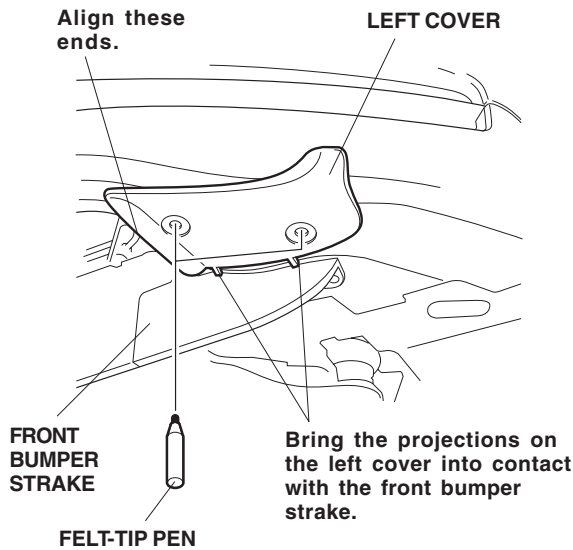

7. Remove the left cover and center punch the marks you made in the bumper.

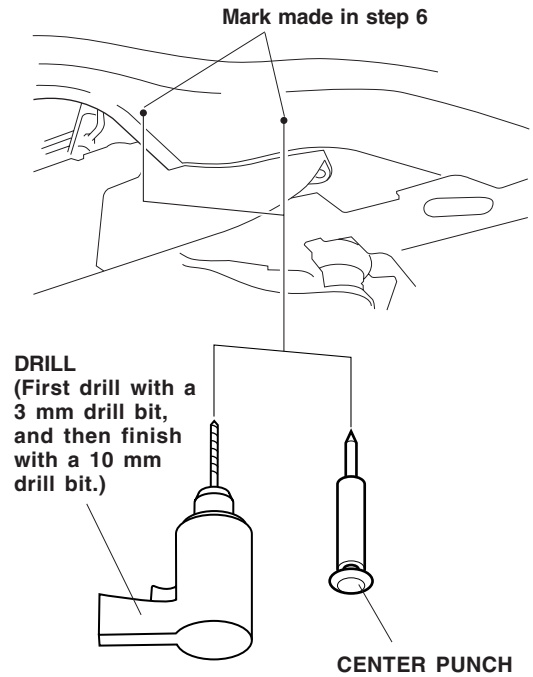

8. While wearing eye protection, drill a 10 mm hole through each marked location. First drill with a 3 mm drill bit, and then finish with a 10 mm drill bit. Remove all burrs from the edges of the holes with a file.
9. Match the left cover, and install with two short clips.

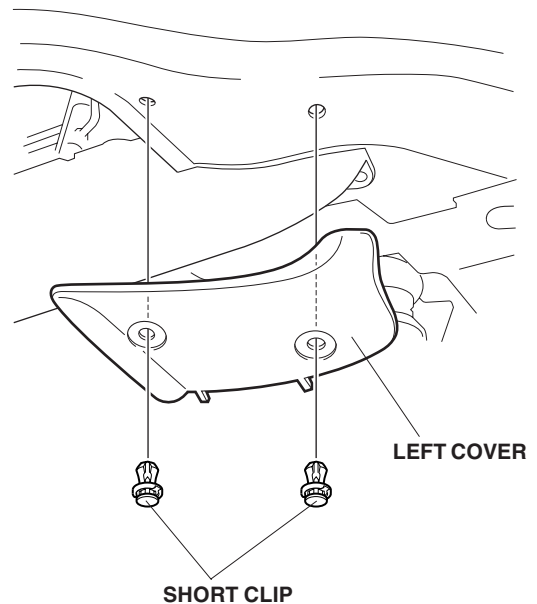

10. Repeat steps 6 thru 9 to install the right cover.

11. Set the template A on the left front inner fender in the area shown, and center punch the left front inner fender through the template. Turn the template over, and mark the right front inner fender the same way.

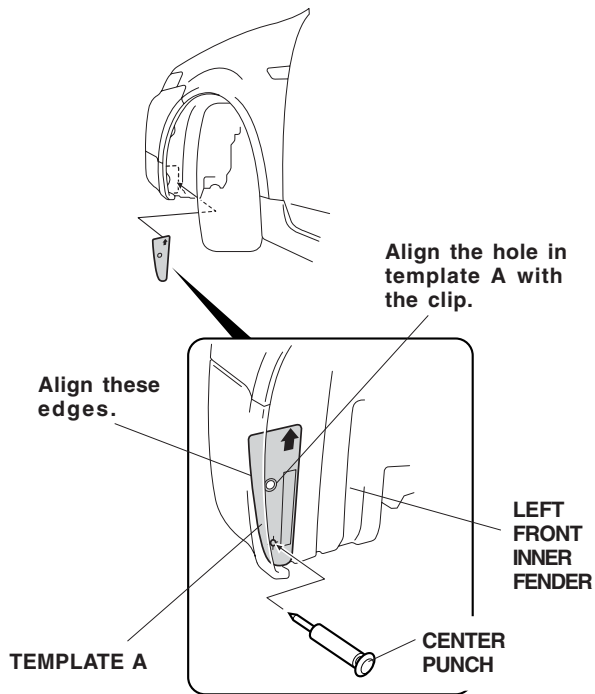

12. While wearing eye protection, drill a 6 mm hole through each center-punched location made in step 11. First drill with a 3 mm drill bit, and then finish with a 6 mm drill bit. Remove all burrs from the edges of the holes with a file. Make sure the front bumper is firmly against the left front inner fender when drilling hole.

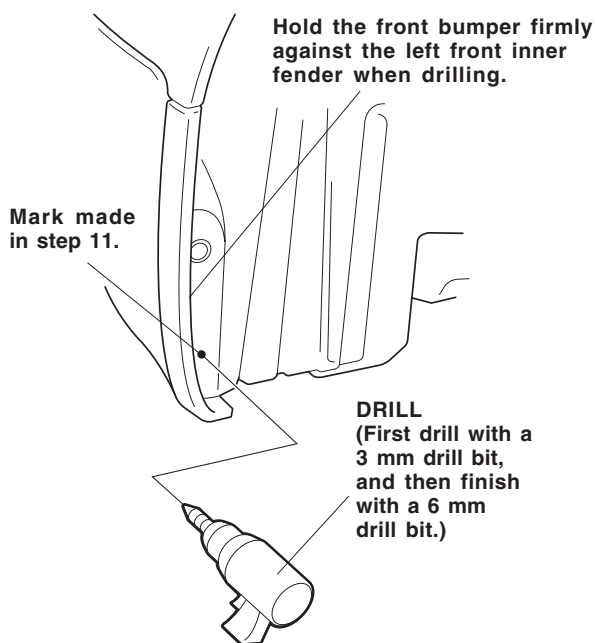

13. Remove the lower clip from the left front inner fender, pull the left front inner fender out, and install one spring nut. If necessary, flatten the spring nut a little to get a tight fit.

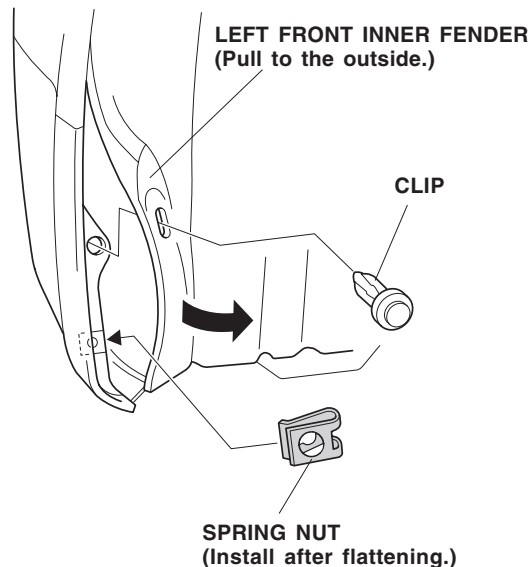

14. Return the left front inner fender to its original position. Get the left bracket, and install the bracket with one clip (reused) and one screw.

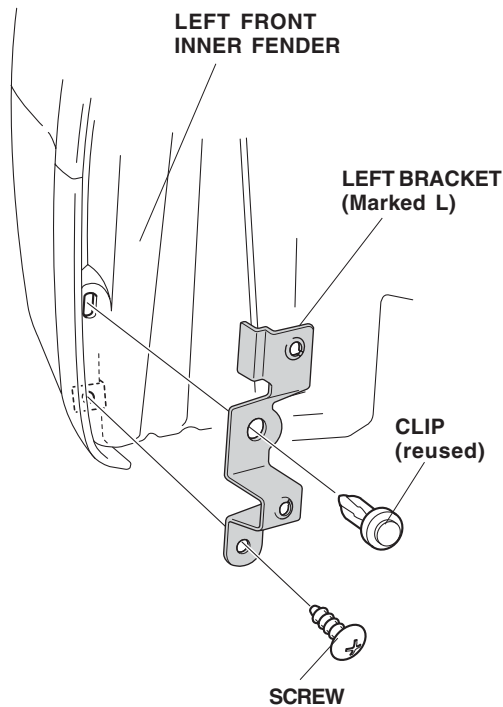

15. Repeat steps 13 and 14 to install the right bracket.

16. On the front under spoiler, at the right and left end, remove 1½ - 2 in. of the adhesive backing from the front end and tape each piece to the front of the spoiler using masking tape. Also remove 1½ - 2 in. of all remaining adhesive backings from each side of each piece of adhesive backing and tape each piece to the front of the spoiler using masking tape.

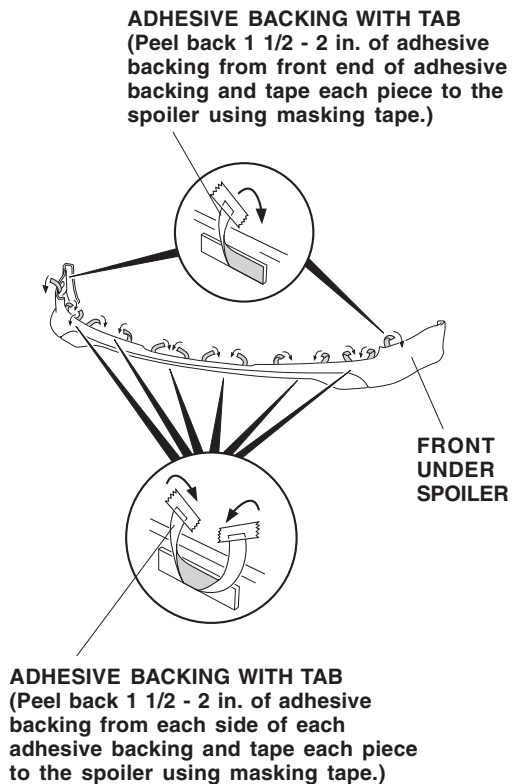

17. Using isopropyl alcohol on a shop towel, thoroughly clean the front bumper where the adhesive tapes will attach to the bumper.

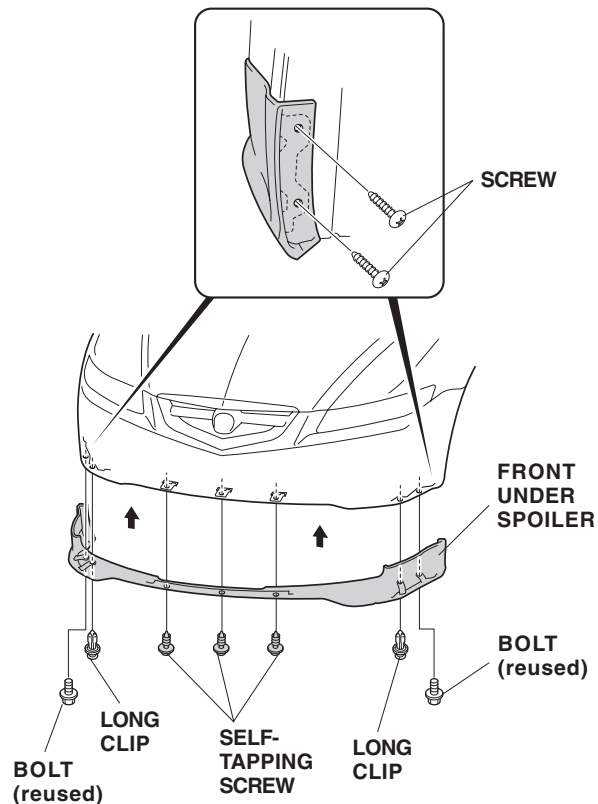

18. Position the front under spoiler on the front bumper and install it with two bolts (reused), the three self-tapping screws (supplied), four screws (supplied) and the two long clips (supplied).

19. Place the front under spoiler against the front bumper and make sure there are no gaps between the under spoiler and the bumper at the location shown.
20. Carefully remove the adhesive backings by pulling on the tabs in the direction shown. Start at the center, then the right and left ends, and finish at edges of the openings in the front bumper. Use extra care when removing the adhesive backings as they can be cut by the edge of the spoiler.

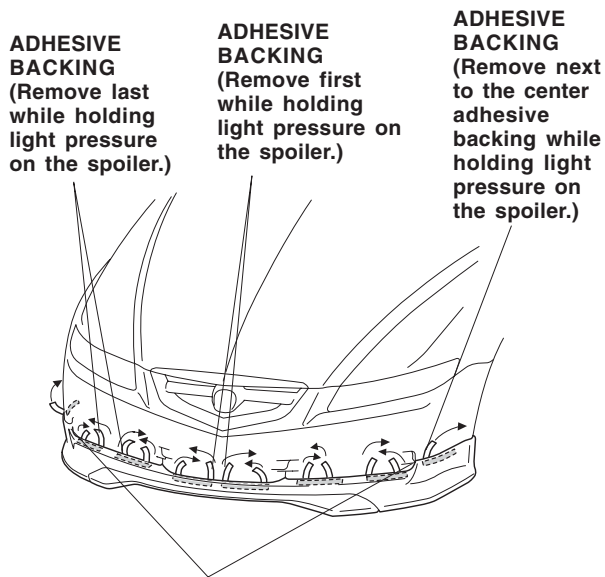

After aligning, check that there are no gaps between the spoiler and front bumper in this area.

21. Hold the spoiler firmly against the front bumper with the palm of your hand for 30 seconds, particularly at the edges.