



INSTALLATION INSTRUCTIONS

Accessory

18" ALUMINUM WHEEL

Application

2005 TL

Publications No.

BII 28144

Issue Date

SEP 2004

PARTS LIST

Aluminum wheel
(The illustration may differ from the actual wheel.)

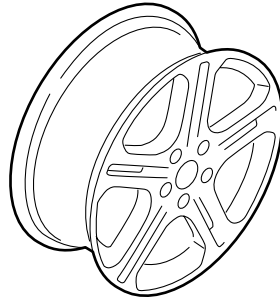

Wheel center cap
(The illustration may differ from the actual center cap.)

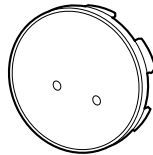

Tire valve



Center cap emblem

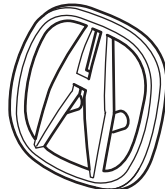

2 Push nuts

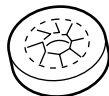

Tire pressure caution label A



Tire pressure caution label B



Important Information

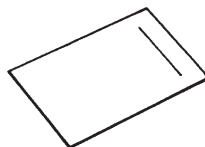

SUPPLIES REQUIRED

Isopropyl alcohol

Shop towel

SPECIFICATIONS

Rim size	18 x 8 1/2 JJ (offset 45)	
Tire size	235/40R18 95W	
Bolt hole PCD	114.3 (5 holes)	
Tire pressure	Front	39 psi (270 kPa, 2.7 kgf/cm ²)
	Rear	36 psi (250 kPa, 2.5 kgf/cm ²)

INSTALLATION

Customer Information: The information in this installation instruction is intended for use only by skilled technicians who have the proper tools, equipment, and training to correctly and safely add equipment to your vehicle. These procedures should not be attempted by "do-it-yourselfers."

NOTE:

- The illustration of the aluminum wheels shown are for reference purposes only.
- Install the correct size tire.
- Use a tire changer to remove and install the tires. Using a tire lever to remove and install the tires can damage to the tire and the wheel.
- The wheel nut torque is 108 N·m (80 lb-ft)
- Be careful not to damage the wheel center cap when installing the emblems.
- This center cap emblem kit should be installed only when the ambient air temperature is 60°F (15°C) or above.
- To allow the adhesive to cure, do not wash the car for 24 hours.
- These instructions are for one center cap emblem. The same procedure applies to installing the three remaining center cap emblems.

1. Using isopropyl alcohol on a shop towel, clean the area where the center cap emblem will attach.
2. Remove the adhesive backing from the center cap emblem.

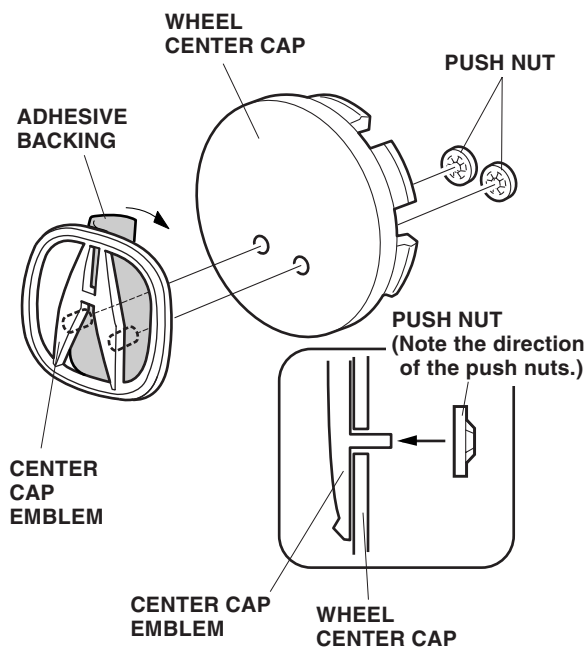

3. Attach the center cap emblem to the wheel center cap by aligning its pins with the holes in the wheel center cap. After attaching, hold the emblem firmly against the wheel center cap with the palm of your hand for 30 seconds.
4. Slide the push nuts, flat-side first, onto the pins. Note the direction of the push nuts.
5. Repeat steps 1 thru 4 to install the three remaining center cap emblems.

6. Open the driver's side door. Using isopropyl alcohol, clean the area where the tire pressure caution label will attach. Remove the adhesive backing from the label and attach it over the existing tire information label. Use tire pressure caution label A or B according to the following information:

Label A: For A/T Model with a T135/80R16 101M spare tire

Label B: For M/T Model with a T145/70R17 106M spare tire

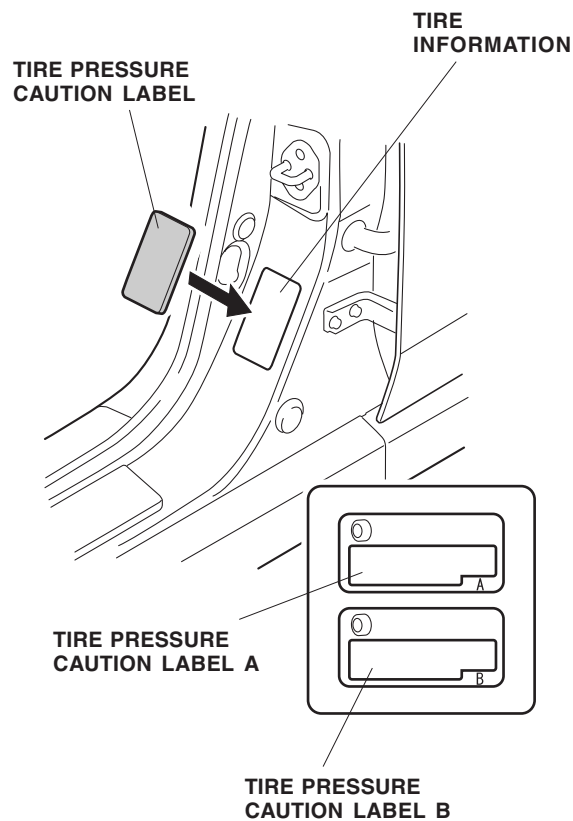

7. Attach the "Important Information" page included in this kit to the Owner's Manual. To install this page to the Owner's Manual, refer to the "To The Dealer" label attached to the Important Information page.

Be sure to explain the contents of the "Important Information" to your customer before delivering the vehicle.