

ACURA
INSTALLATION
INSTRUCTIONS

Accessory
MOONROOF VISOR
 P/N 08R01-SJA-200

Application
2005 RL

Publications No.
BII 27031
 Issue Date
SEP 2004

Put this information in the glove box with the vehicle owner's manual.

PARTS LIST

Moonroof visor

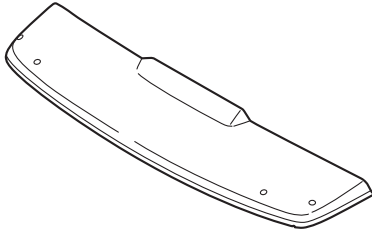

2 Front brackets

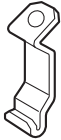

2 Side brackets



4 Nuts



4 Protective tapes



4 Screws



TOOLS AND SUPPLIES REQUIRED

- 10 mm Combination wrench
- #2 Phillips screwdriver
- Masking tape
- Isopropyl alcohol
- Shop towel
- Straightedge
- Felt-tip pen

INSTALLATION

1. Clean the roof area to be covered, and wax the area with a high-quality paste wax.
2. Open the moonroof and hold down the air spoiler.
3. Using isopropyl alcohol on a shop towel, clean the roof area and the inside edge of the moonroof opening where the protective tapes will attach.

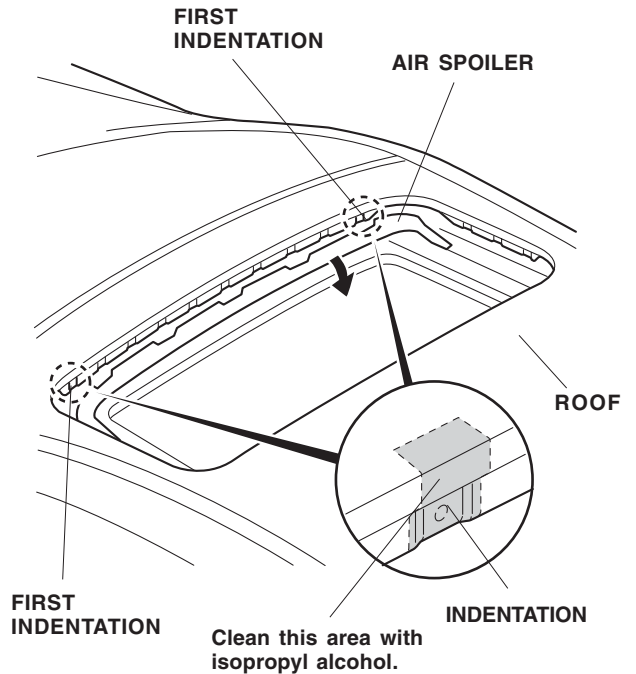

- Remove the adhesive backing from one of the protective tapes. Starting at the bottom edge of the tape, wrap 6 mm (0.2 in.) of the protective tape around the lip of the moonroof opening to cover one of the located indentations; continue upward with the tape around the top of the roof panel.

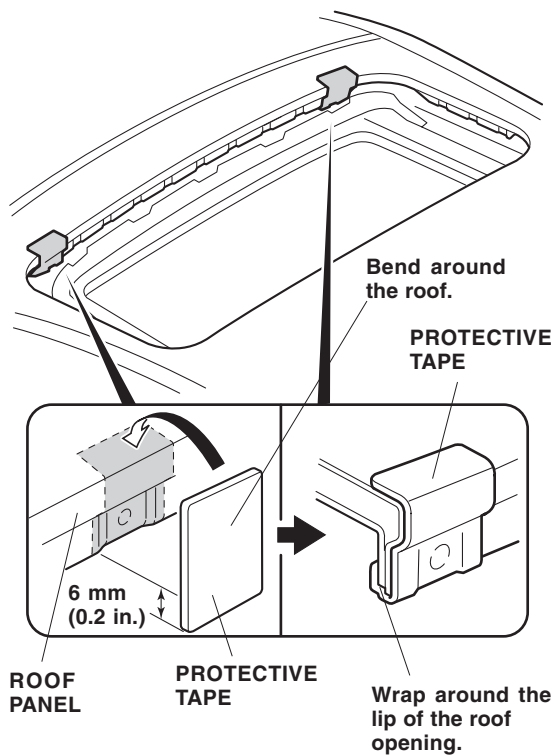

- Using the same procedure, attach the other protective tape to the roof at the other located indentation.

- At the right front corner of the moonroof opening, locate the front moonroof guide rail screw. Place a straightedge 90 degrees directly outboard from the screw as shown, and mark the edge of the roof with a felt-tip pen.

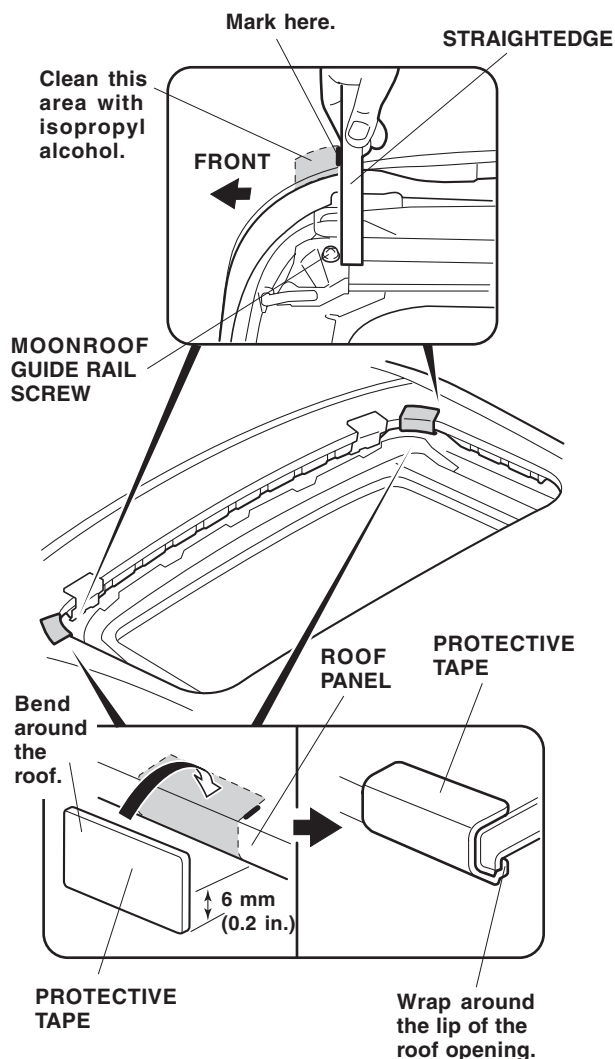

- Using isopropyl alcohol on a shop towel, clean the roof area and the inside edge of the moonroof opening from the felt-tip mark to an area about 50 mm (2 in.) forward of the felt-tip mark.
- Remove the adhesive backing from one of the protective tapes. Starting at the bottom edge, wrap 6 mm (0.2 in.) of the protective tape around the lip of the moonroof opening just in front of the felt-tip mark; continue upward with the tape around the top of the roof panel.
- Repeat steps 6 thru 8 to install the protective tape on the left side of the moonroof opening. Remove the felt-tip marks you made using isopropyl alcohol on a shop towel.

- Place the two side brackets into position over the protective tape and around the lip of the roof opening, and secure them into position with a piece of masking tape.

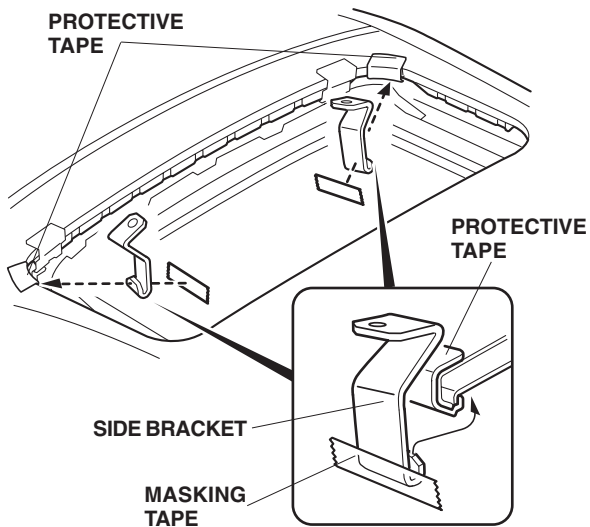

- Set the moonroof visor on the vehicle roof in front of the moonroof opening, and adjust its position so the holes in the visor are aligned with the side bracket holes. Install two screws and nuts loosely onto the side brackets.

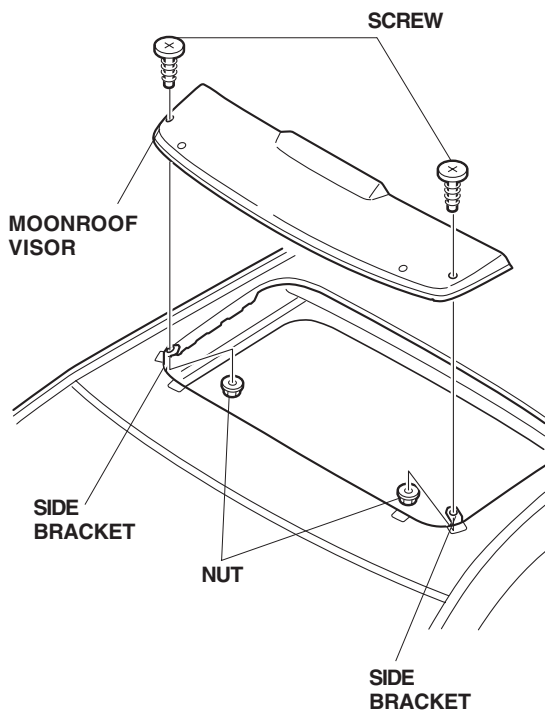

- Insert a screw through the two remaining holes on the top of the visor; then loosely install the front brackets and nuts as shown. Be sure to align the lower end of the front brackets with the indentation in the lip.

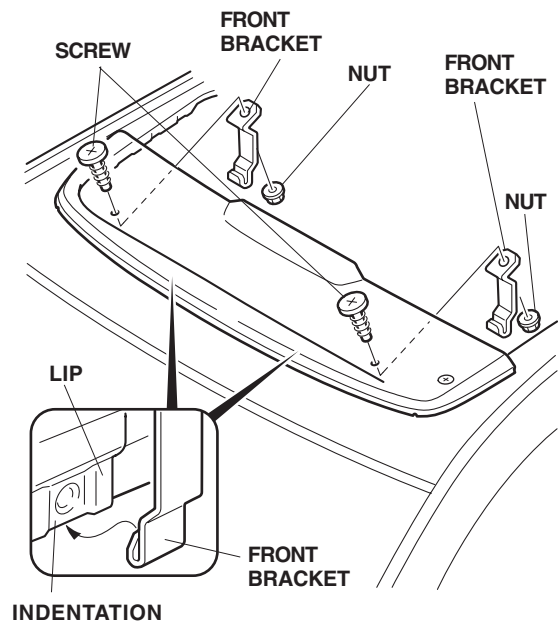

13. Position the moonroof visor with equal spacing on all sides. Check that the rubber seal is not twisted or rolled under the visor.

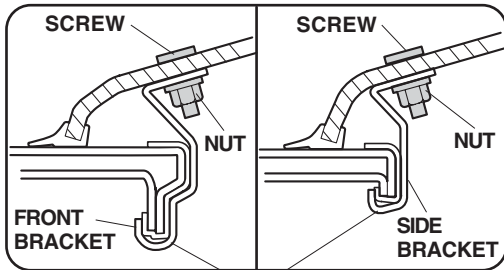
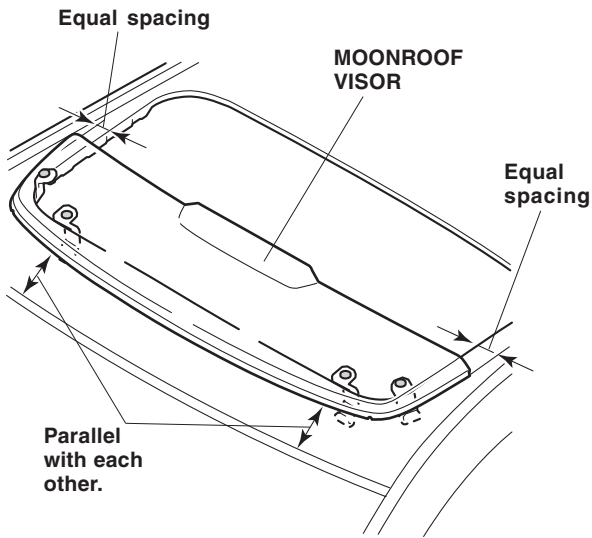

Make sure the bracket is tight against the lip of the moonroof opening.

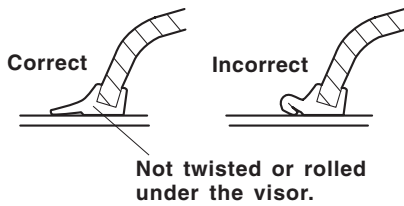

14. Tighten the nuts and screws, alternating between sides. To prevent damage to the moonroof visor and the nuts, do not overtighten the screws.

CARE OF THE MOONROOF VISOR

- To avoid damaging the surface, never use ammonia-based cleaners or solvents to clean the moonroof visor.
- Clean with a solution of mild dishwashing soap and water using a soft cloth or chamois.
- To remove fine scratches and restore the original luster, use Meguiar's Mirror Glaze plastic cleaner and polish or an equivalent high-quality plastic cleaner.